

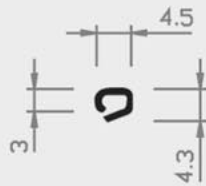

Nr. 4/14 W



Nr. 4/15 H



Nr. 5/7 HH

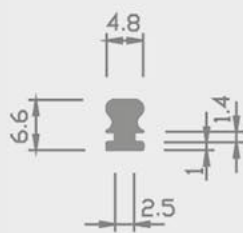

Nr. 5/8 HH

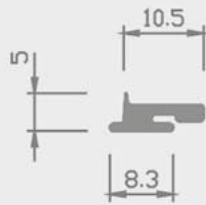

Nr. 5/6 W



Nr. 4/7 W

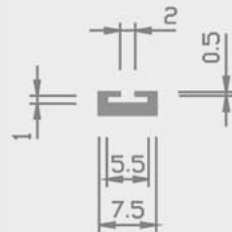

Nr. 23/30 W



Nr. 5/14 LDPE

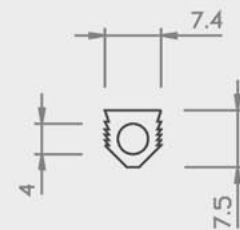

Nr. 9/26 HDPE

= Hart PVC
 = Weich PVC | HH = Halbhart PVC
 = Andere Kunststoffe

20 | SONDERPROFILE



Nr. 1/70 H

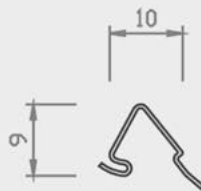

Nr. 11/75 PE



Nr. 4/12 H

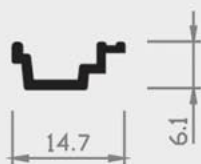

Nr. 23/31 H

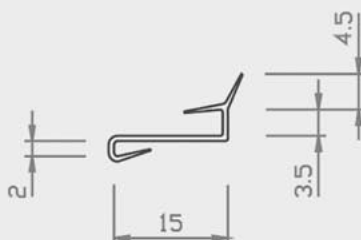

Nr. 12/91 PE

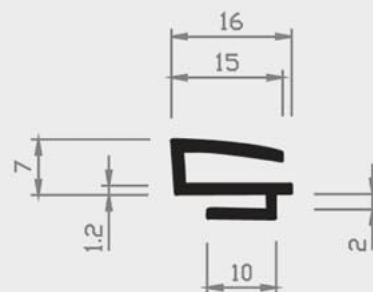

Nr. 30/19 H



Nr. 11/69 HH



Nr. 12/69 PE



Nr. 11/70 PE

= Hart PVC
 = Weich PVC | HH = Halbhart PVC
 = Andere Kunststoffe

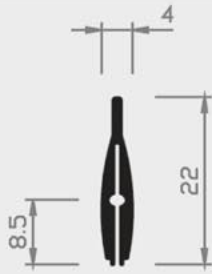

Nr. 4/8a H

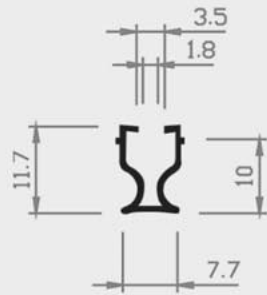

Nr. 4/9 H

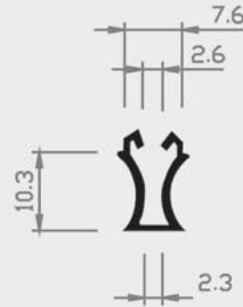

Nr. 4/9a H

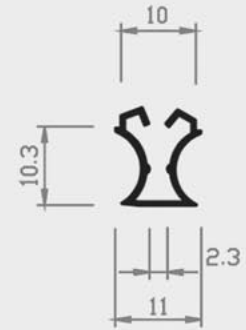

Nr. 4/11 H

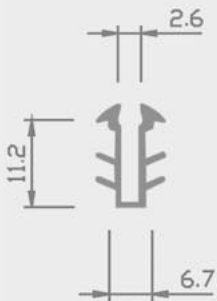

Nr. 4/13 W

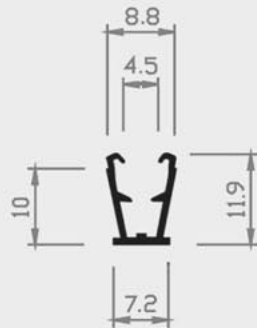

Nr. 4/16 H

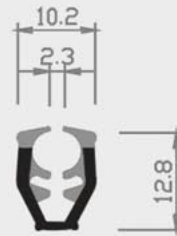

Nr. 24/6 H+W
geschützt



Nr. 24/2 PE

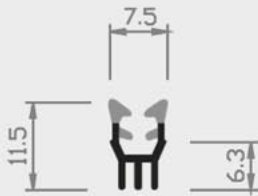

Nr. 24/7 H+W

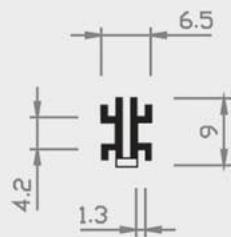

Nr. 5/11a H+W



Nr. 7/20 H



Nr. 5/12 PUR

= Hart PVC
 = Weich PVC | HH = Halbhart PVC
 = Andere Kunststoffe

20 | SONDERPROFILE

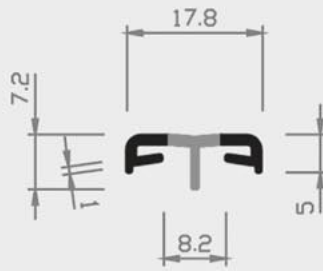

Nr. 7/18 H+W

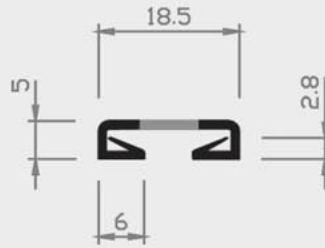

Nr. 5/1 H+W

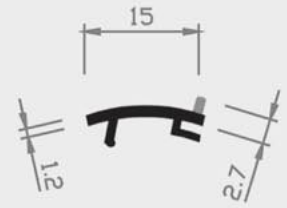

Nr. 24/5 H+W
Nr. 24/5a H ohne Lippe
geschützt

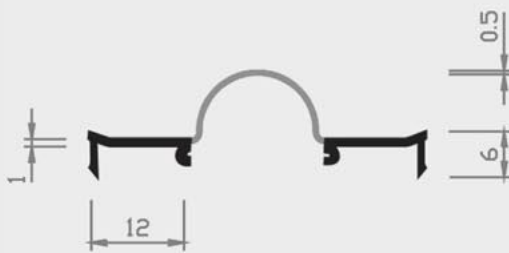

Nr. 24/11 H+W
geschützt

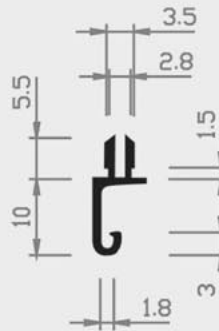

Nr. 4/10 H

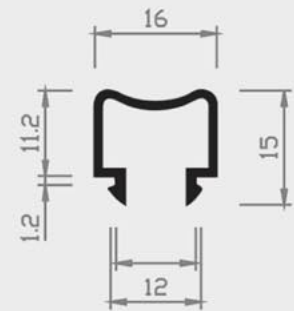

Nr. 7/21 H

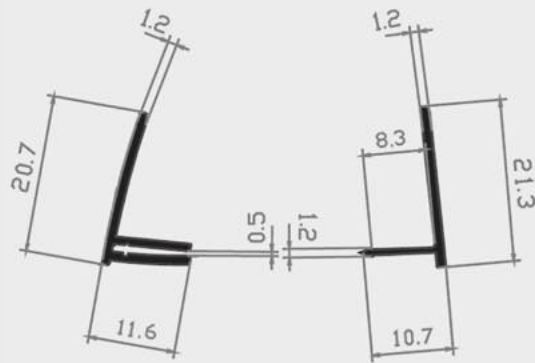

Nr. 6/10a H

Nr. 6/10b H

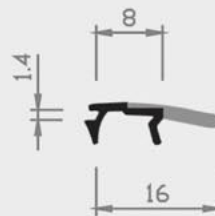

Nr. 1/34 H+W



Nr. 24/1 H
geschützt

■ = Hart PVC ■ = Weich PVC | HH = Halbhart PVC □ = Andere Kunststoffe

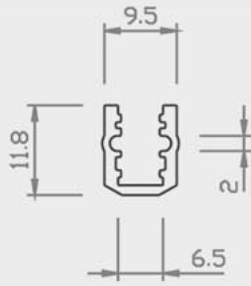

Nr. 4/19 ABS



Nr. 22/61 HH
geschützt

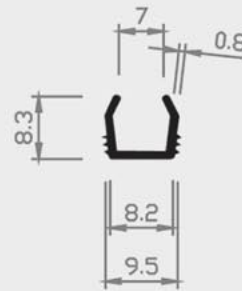

Nr. 19/1 H



Nr. 1/68 W

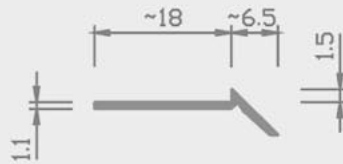

Nr. 9/39 HH

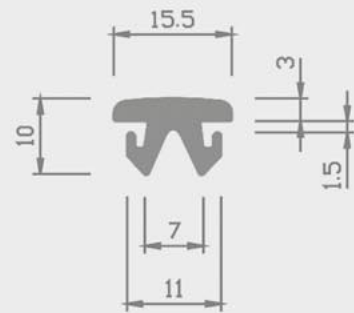

Nr. 11/80 W



Nr. 18/22 H

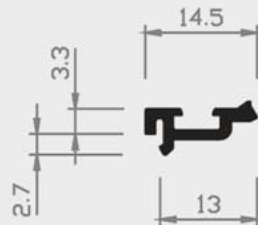

Nr. 26/23 H



Nr. 11/81 W

= Hart PVC
 = Weich PVC | HH = Halhart PVC
 = Andere Kunststoffe

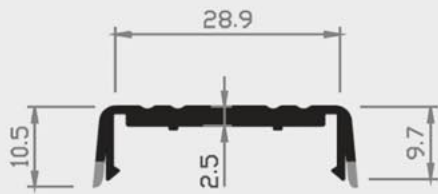

Nr. 4/17 H+W

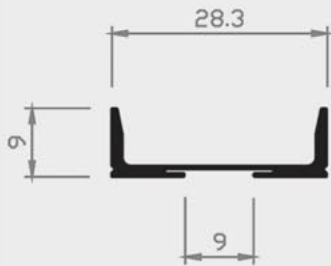

Nr. 4/18 H
geschützt

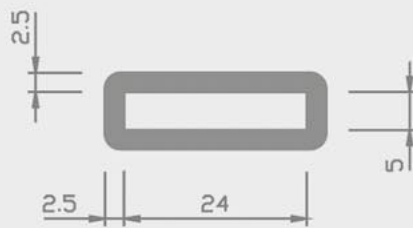

Nr. 15/93 W

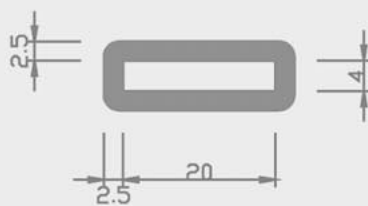

Nr. 15/92 W

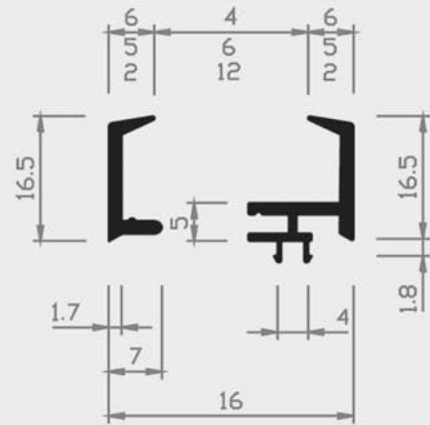

Nr. 29/18 H

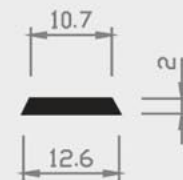

Nr. 25/45 H
geschützt

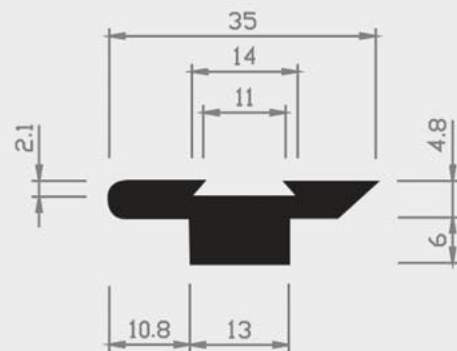

Nr. 25/44 H 6mm
Nr. 25/44a H 5mm
geschützt

= Hart PVC
 = Weich PVC | HH = Halbhart PVC
 = Andere Kunststoffe

20 | SONDERPROFILE

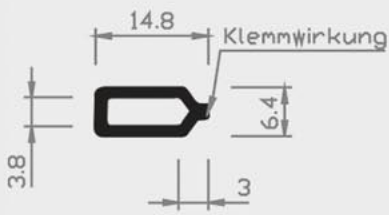

Nr. 55/22 H

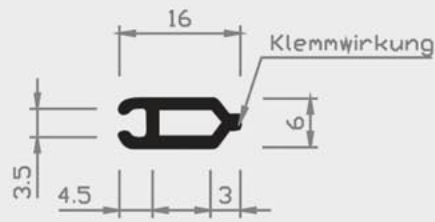

Nr. 55/23 H

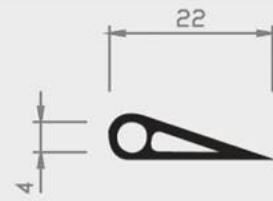

Nr. 58/22 H

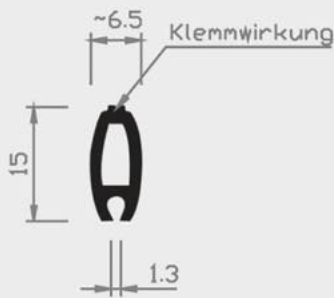

Nr. 54/23 H

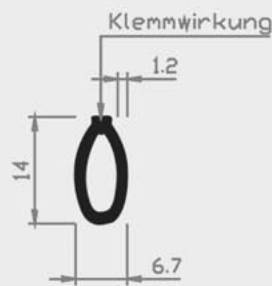

Nr. 54/22 H



Nr. 57/22 H

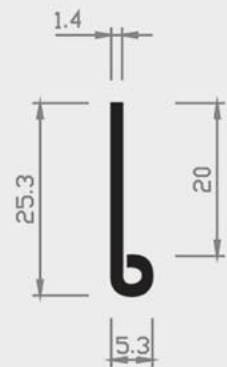

Nr. 57/23 H

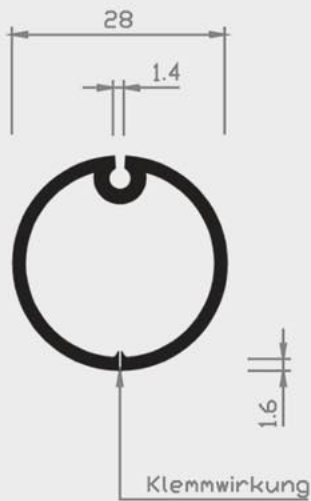

Nr. 56/22 H

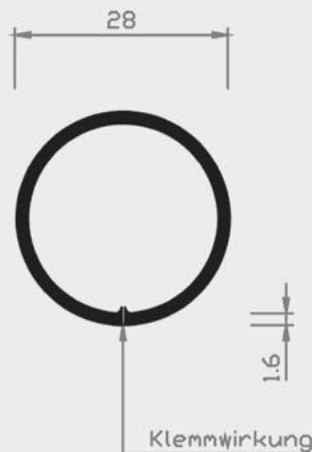

Nr. 56/23 H

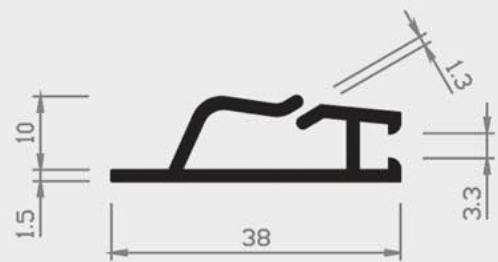

Nr. 54/28 H

= Hart PVC
 = Weich PVC | HH = Halbhart PVC
 = Andere Kunststoffe

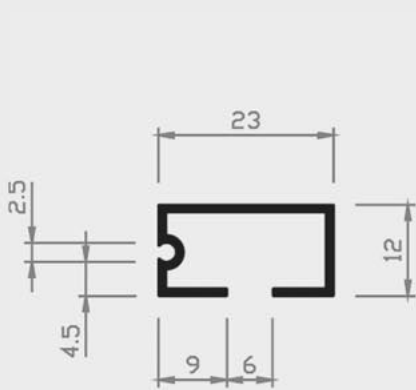

Nr. 11/86 H

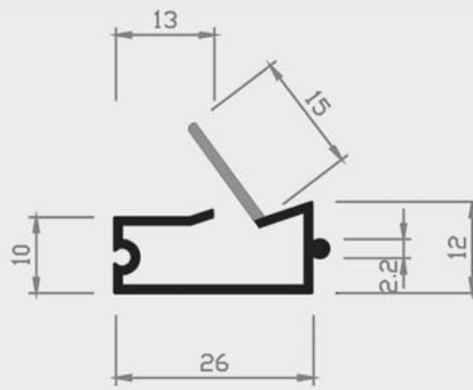

Nr. 11/87 H+W
geschützt

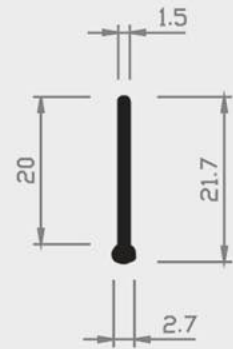

Nr. 52/22 H

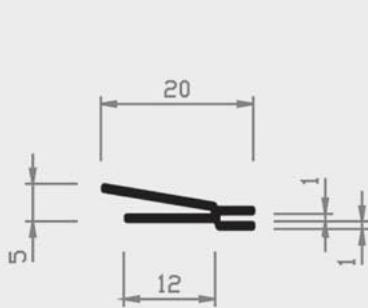

Nr. 10/89 H

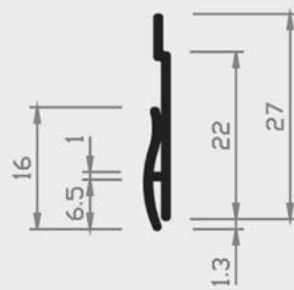

Nr. 11/89 H
geschützt

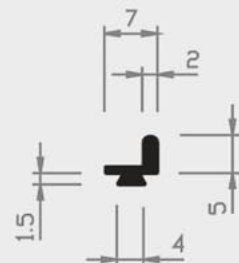

Nr. 14/62 H

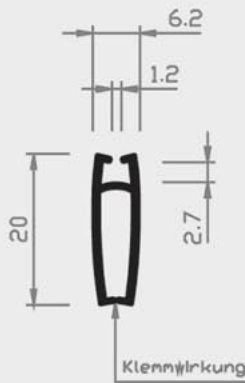

Nr. 55/26 H
geschützt

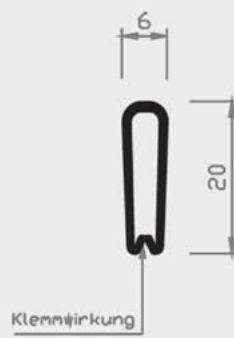

Nr. 55/25 H
geschützt

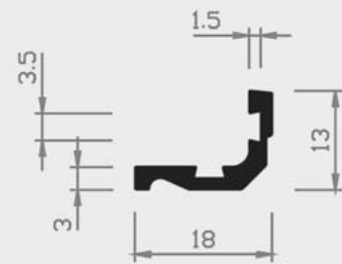

Nr. 14/68 H

■ = Hart PVC

■ = Weich PVC | HH = Halbhart PVC

□ = Andere Kunststoffe

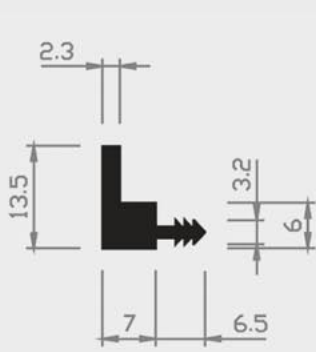

Nr. 19/33 H

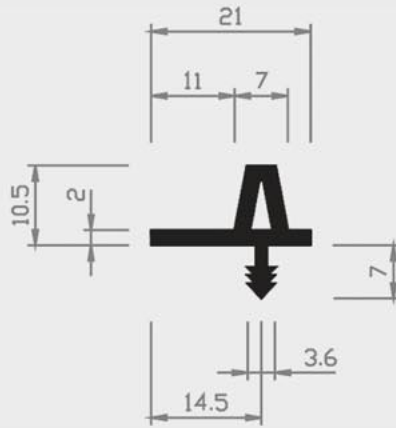

Nr. 13/37 H

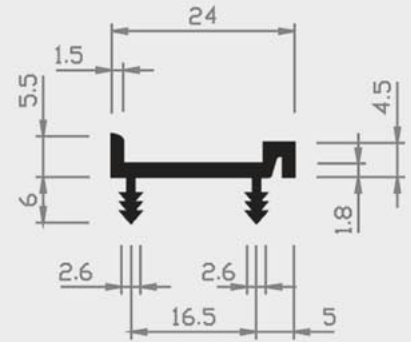

Nr. 14/51 H

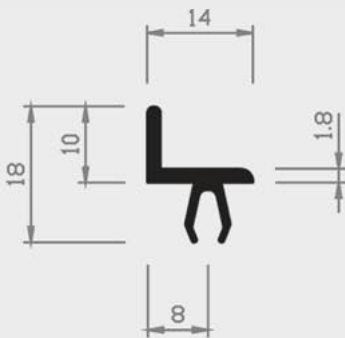

Nr. 21/88 H

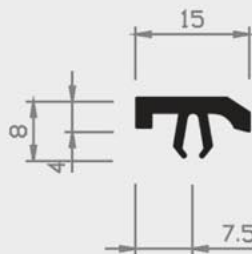

Nr. 20/88 H

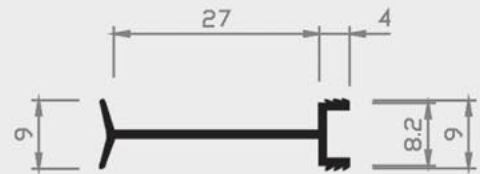

Nr. 11/39 H

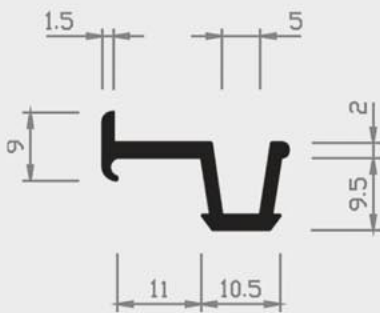

Nr. 12/37 H

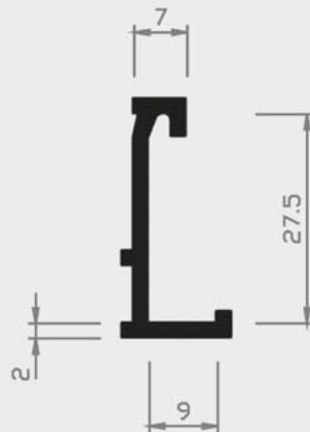

Nr. 14/90 H



Nr. 55/15 W

= Hart PVC
 = Weich PVC | HH = Halbhart PVC
 = Andere Kunststoffe

20 | SONDERPROFILE

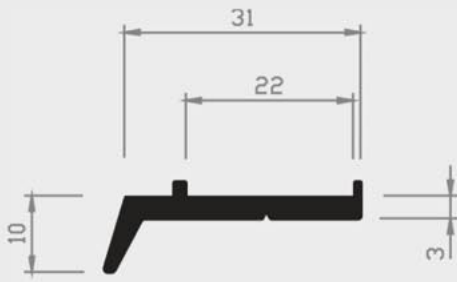

Nr. 1/62 H

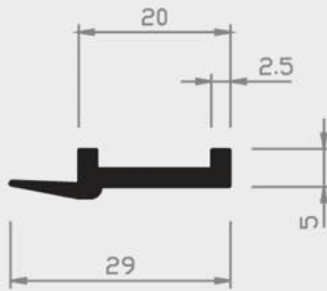

Nr. 1/69 H

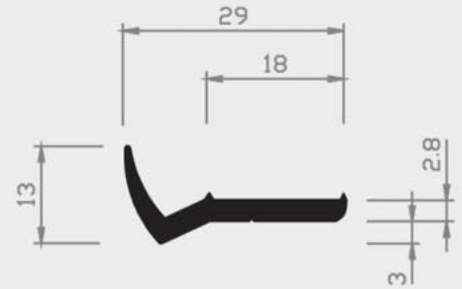

Nr. 1/65 H



Nr. 1/71 H

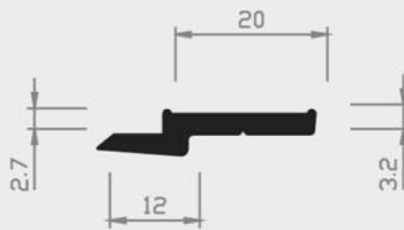

Nr. 1/66 H

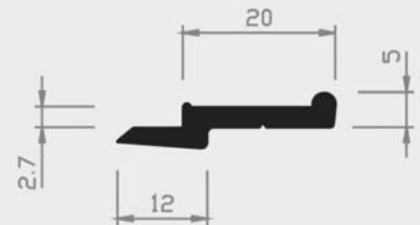

Nr. 1/66a H

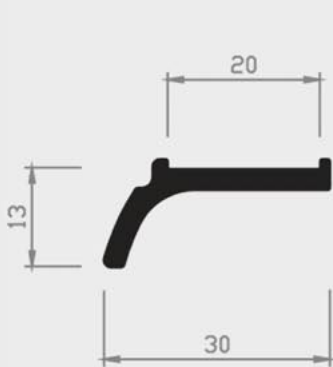

Nr. 1/61 H

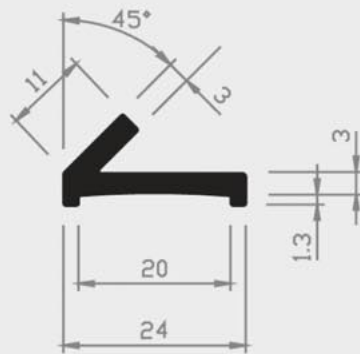

Nr. 1/60 H

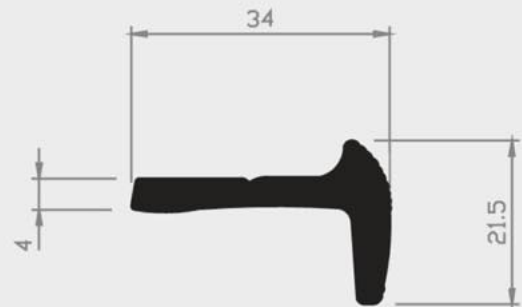

Nr. 1/67 H

= Hart PVC
 = Weich PVC | HH = Halbhart PVC
 = Andere Kunststoffe

20 | SONDERPROFILE



Nr. 3/64a W

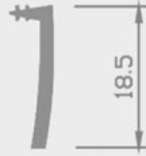

Nr. 3/64c W



Nr. 3/64b W

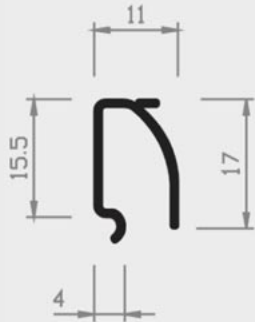

Nr. 15/89 H

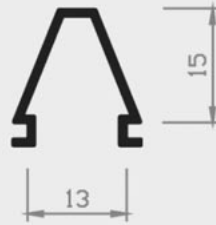

Nr. 7/23 H



Nr. 3/64d W

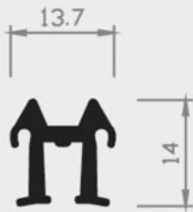

Nr. 20/61 H

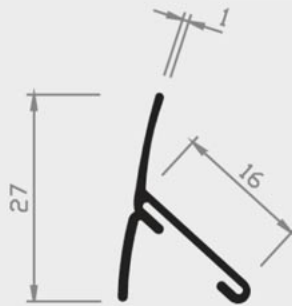

Nr. 18/91 H

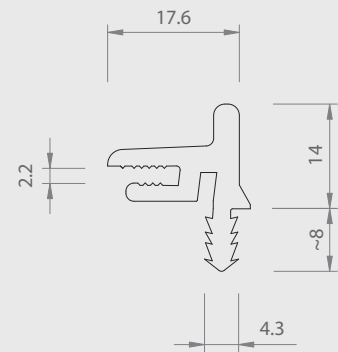

Nr. 15/38 PP

= Hart PVC
 = Weich PVC | HH = Halbhart PVC
 = Andere Kunststoffe

20 | SONDERPROFILE

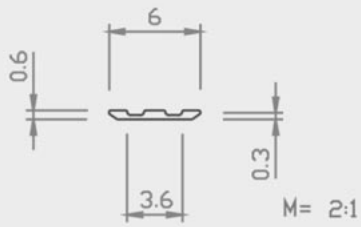

Nr. 9/67 6mm PP

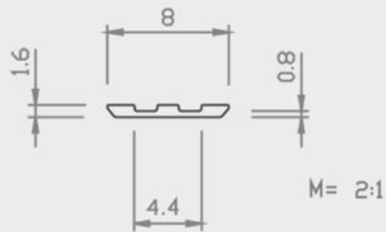

Nr. 9/67 8mm PP

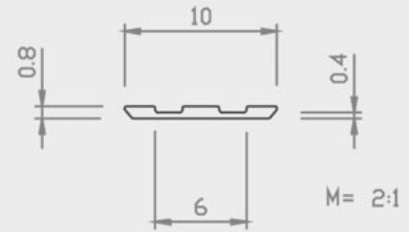

Nr. 9/67 10mm PP

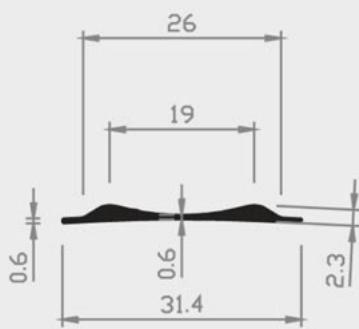

Nr. 3/10 31,4mm H

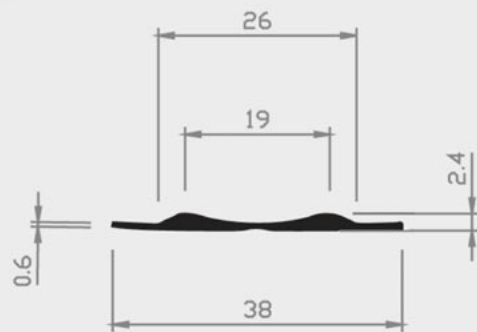

Nr. 3/10 38mm H

= Hart PVC
 = Weich PVC | HH = Halbhart PVC
 = Andere Kunststoffe

20 | SONDERPROFILE

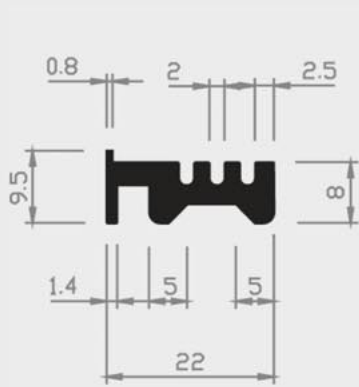

Nr. 21/58 H

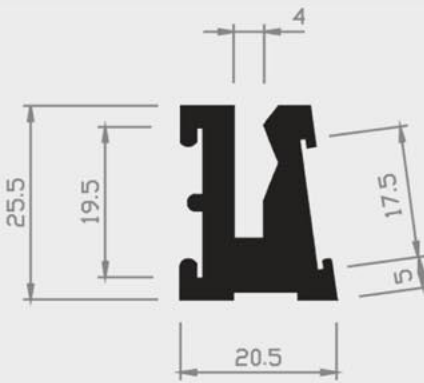

Nr. 21/59 H

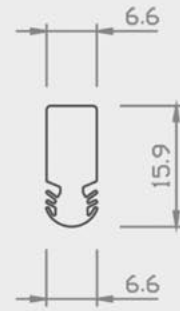

Nr. 8/27 ABS

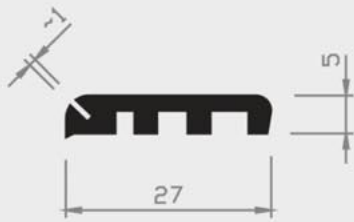

Nr. 12/95 H



Nr. 20/67 HH

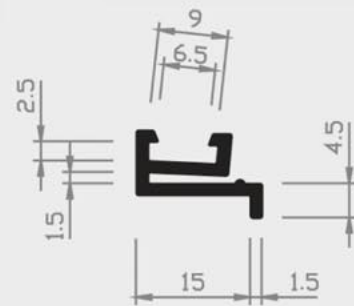

Nr. 30/10 H

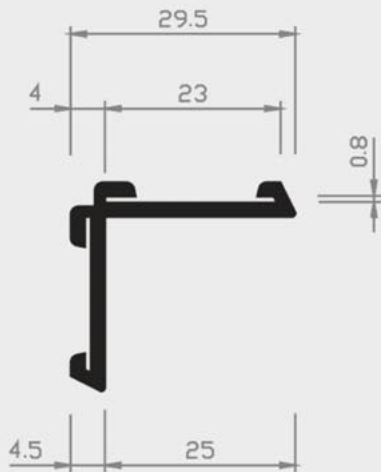

Nr. 22/90 H

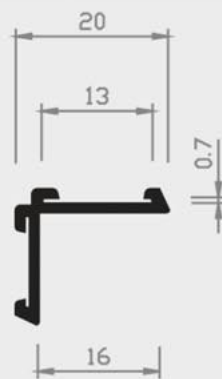

Nr. 20/90 H



Nr. 20/89 H

= Hart PVC
 = Weich PVC | HH = Halbhart PVC
 = Andere Kunststoffe

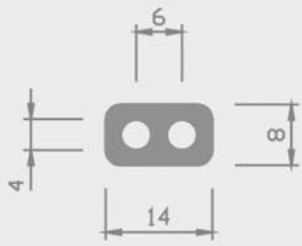

Nr. 15/86 W

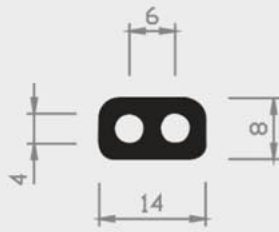

Nr. 15/86 H

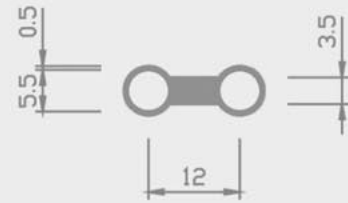

Nr. 15/91 W

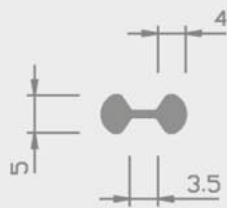

Nr. 15/77 W

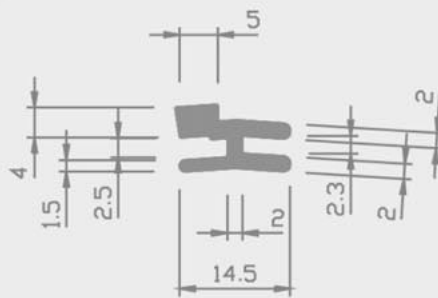

Nr. 20/59 HH

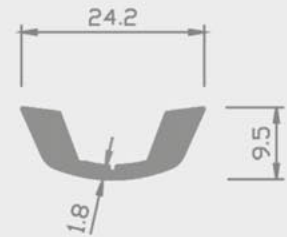

Nr. 22/59 HH

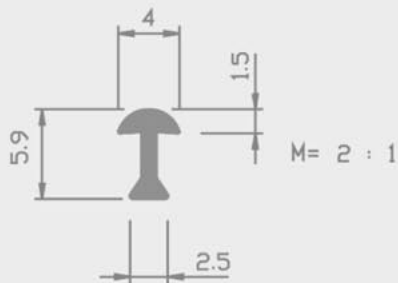

Nr. 9/79 HH



Nr. 20/68 HH

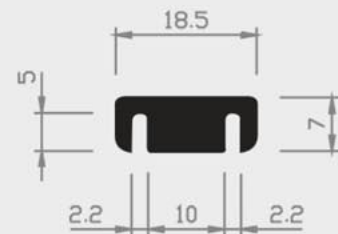

Nr. 12/94 H

= Hart PVC
 = Weich PVC | HH = Halhart PVC
 = Andere Kunststoffe

20 | SONDERPROFILE

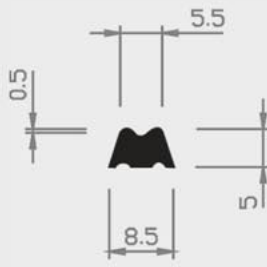

Nr. 16/67 H

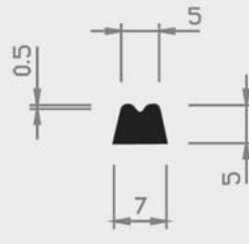

Nr. 17/67 H



Nr. 18/67 H

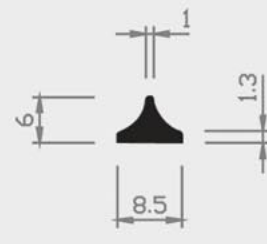

Nr. 19/67 H

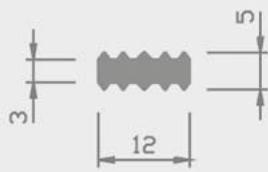

Nr. 10/83 W

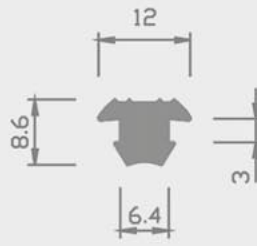

Nr. 60/85 W

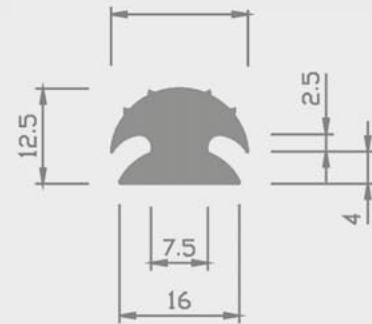

Nr. 61/85 W

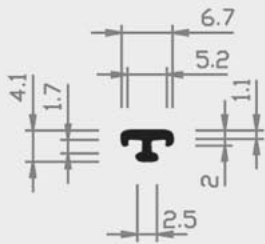

Nr. 11/67 H

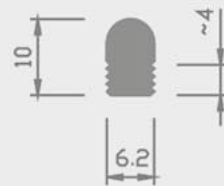

Nr. 13/31 W

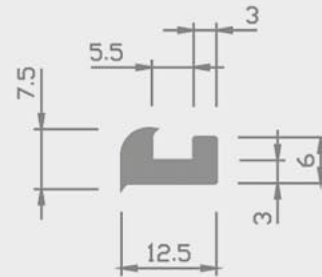

Nr. 61/54 HH

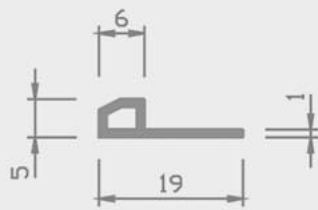

Nr. 8/63 HH

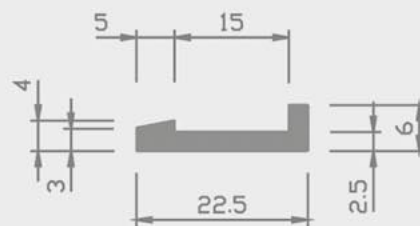

Nr. 12/14 HH

■ = Hart PVC ■ = Weich PVC | HH = Halbhart PVC □ = Andere Kunststoffe

20 | SONDERPROFILE



Nr. 50/18 H

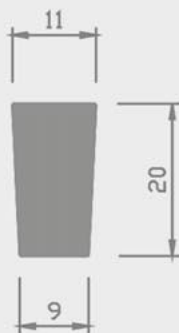

Nr. 62/14 W



Nr. 17/13 W

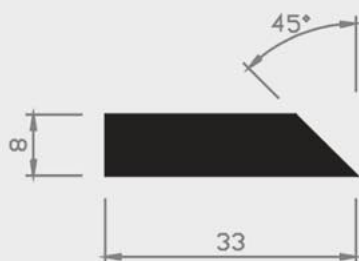

Nr. 14/49 H

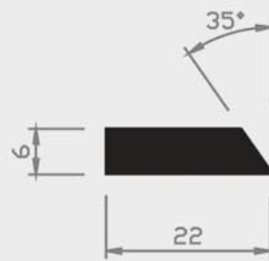

Nr. 14/44a H

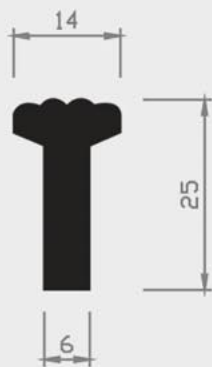

Nr. 25/20 H

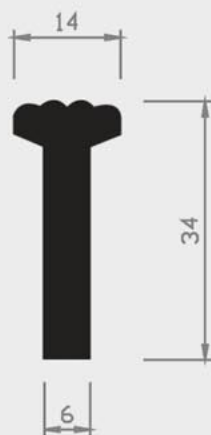

Nr. 25/19 H

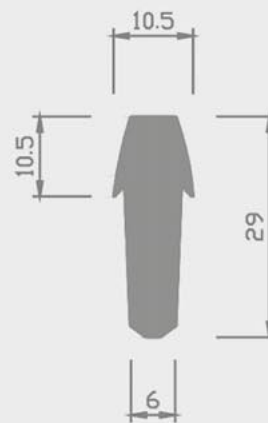

Nr. 16/75 W

= Hart PVC
 = Weich PVC | HH = Halbhart PVC
 = Andere Kunststoffe



Nr. 50/15 W



Nr. 50/16 W



Nr. 50/17 W

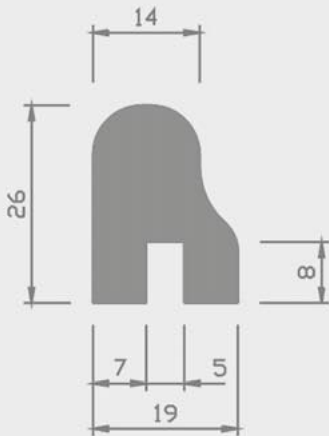

Nr. 18/4 W

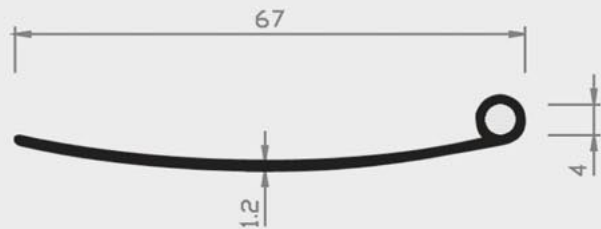

Nr. 58/23 H

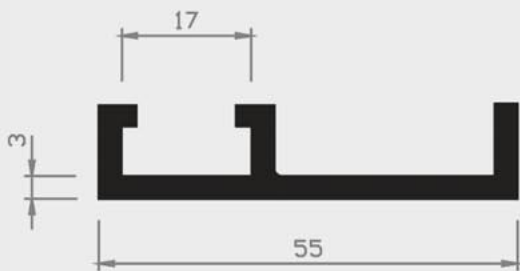

Nr. 18/58 W



Nr. 14/96 HH

= Hart PVC
 = Weich PVC | HH = Halbhart PVC
 = Andere Kunststoffe

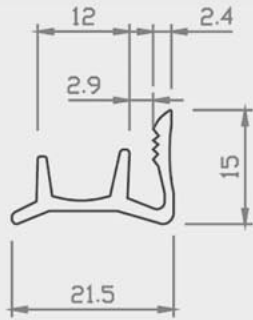

Nr. 20/30 ABS
geschützt

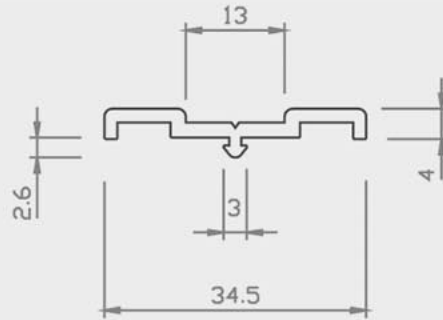

Nr. 19/2 ABS

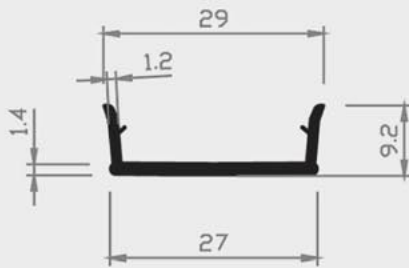

Nr. 16/69 H
geschützt

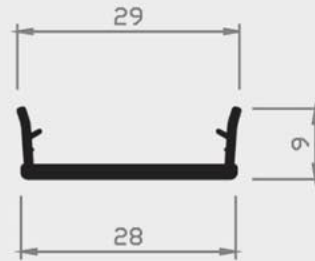

Nr. 17/69 H
geschützt



Nr. 10/86 W

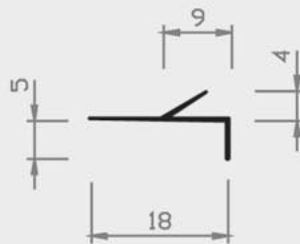

Nr. 11/5 H

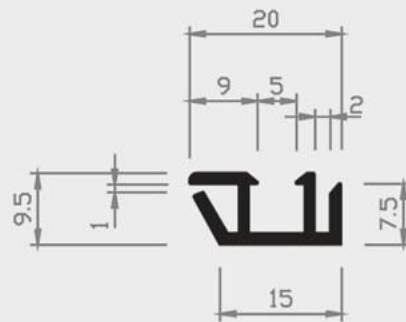

Nr. 17/23 H

= Hart PVC
 = Weich PVC | HH = Halbhart PVC
 = Andere Kunststoffe

20 | SONDERPROFILE

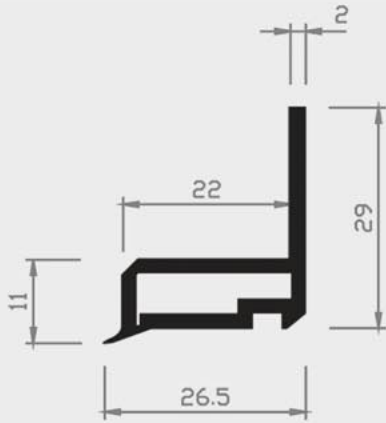

Nr. 17/25 H

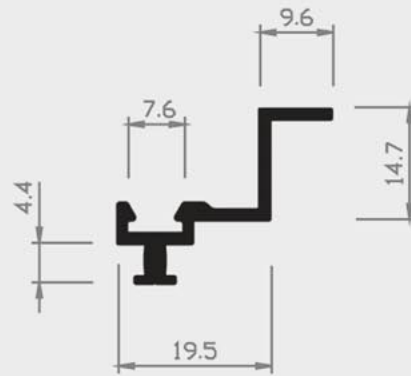

Nr. 16/20 H
geschützt

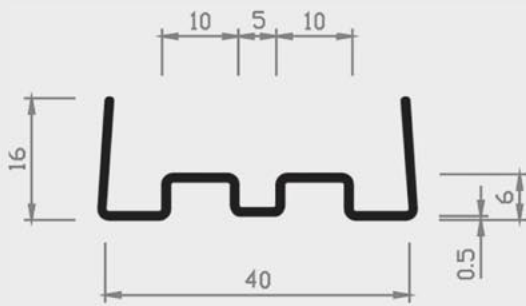

Nr. 54/36 H

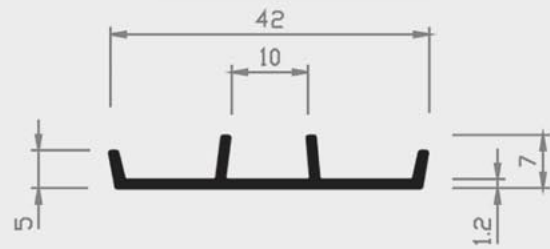

Nr. 12/83 H

= Hart PVC
 = Weich PVC | HH = Halbhart PVC
 = Andere Kunststoffe

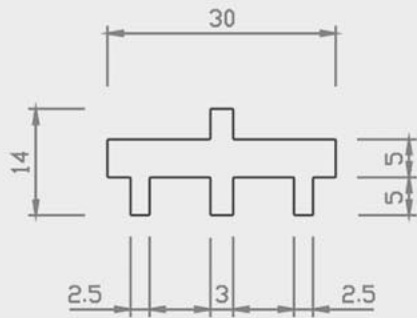

Nr. 14/66 PE

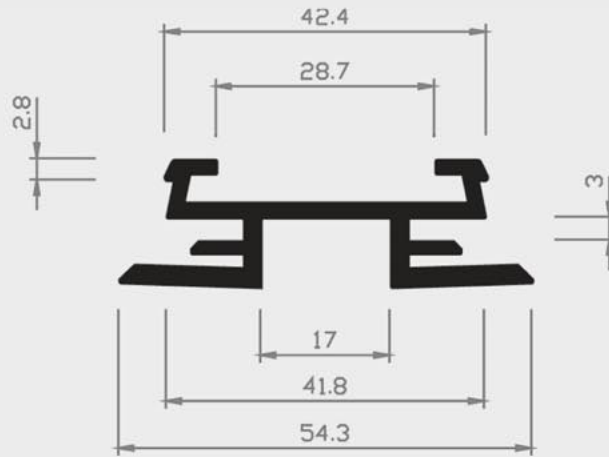

Nr. 21/96 H
geschützt

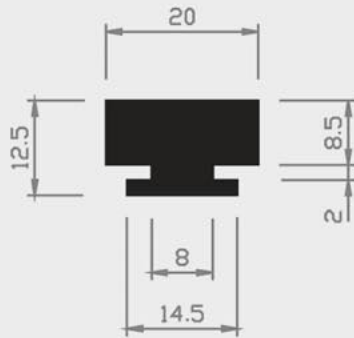

Nr. 25/1 H

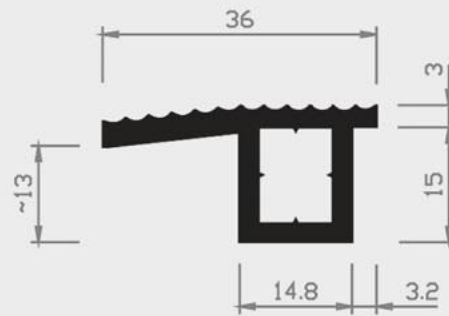

Nr. 29/5 H

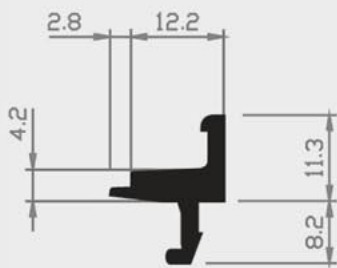

Nr. 16/38 H



Nr. 15/40 H

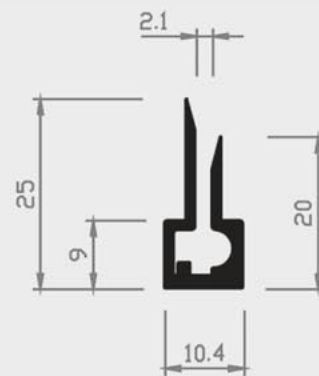

Nr. 5/37 H

= Hart PVC
 = Weich PVC | HH = Halbhart PVC
 = Andere Kunststoffe

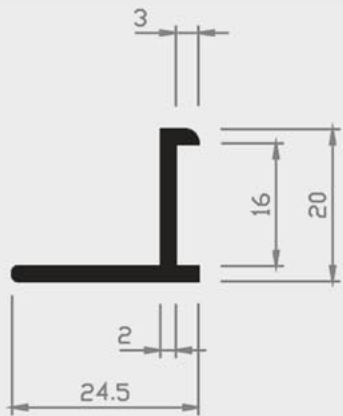

Nr. 15/66 H

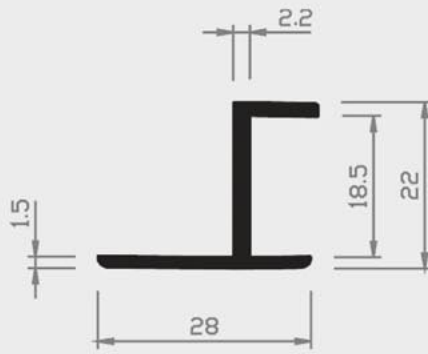

Nr. 16/66 H

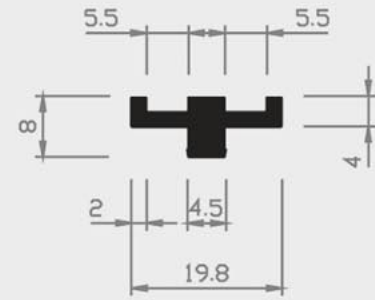

Nr. 19/30 H

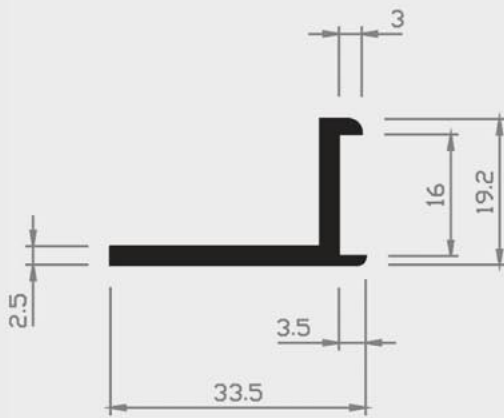

Nr. 15/67 H

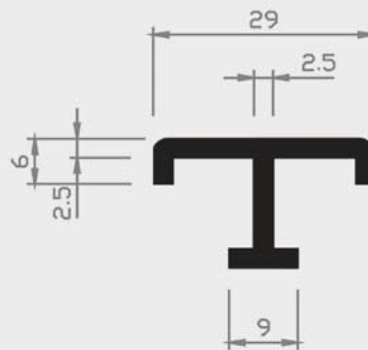

Nr. 17/37 H

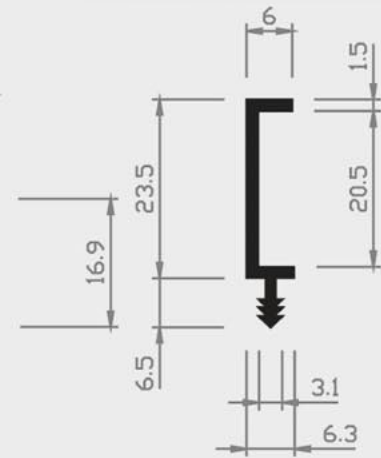

Nr. 14/16 H

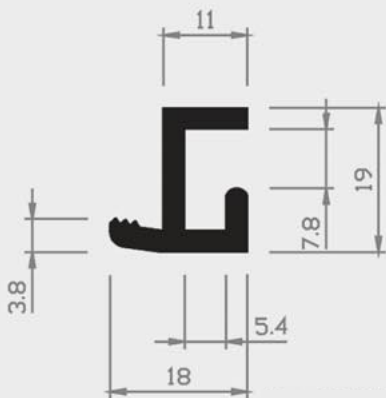

Nr. 16/33 H

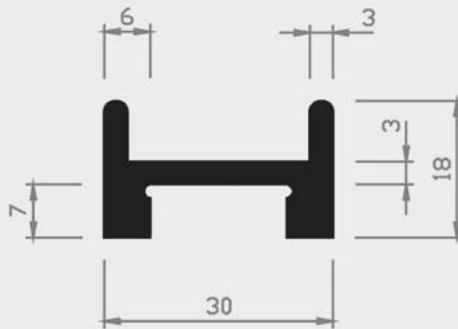

Nr. 12/59 H

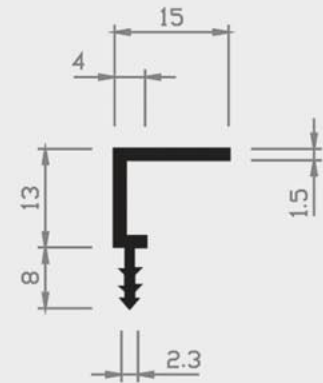

Nr. 15/16 H

= Hart PVC
 = Weich PVC | HH = Halbhart PVC
 = Andere Kunststoffe

20 | SONDERPROFILE

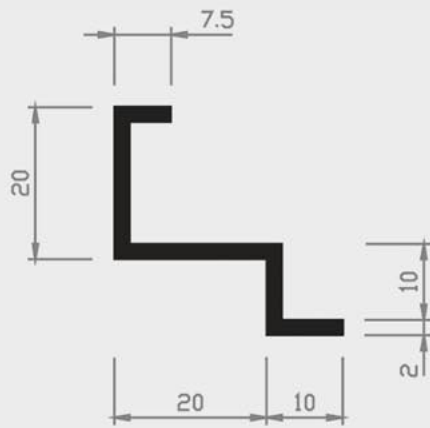

Nr. 15/18 H

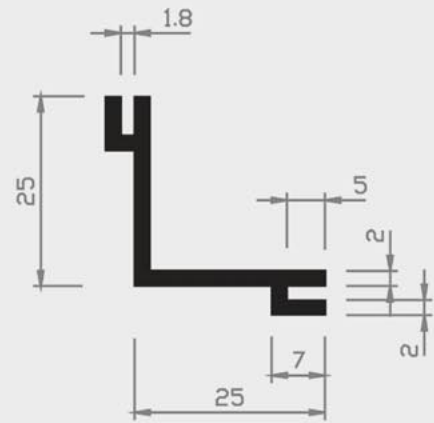

Nr. 20/63 H

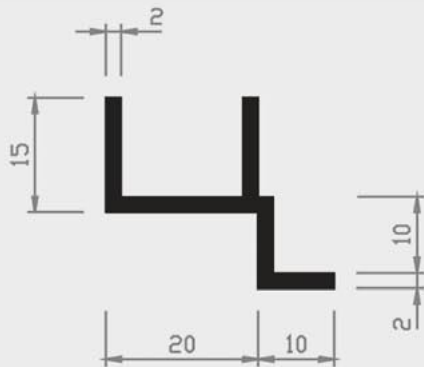

Nr. 14/18 H

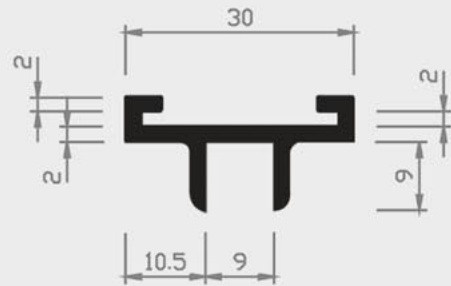

Nr. 19/90 H

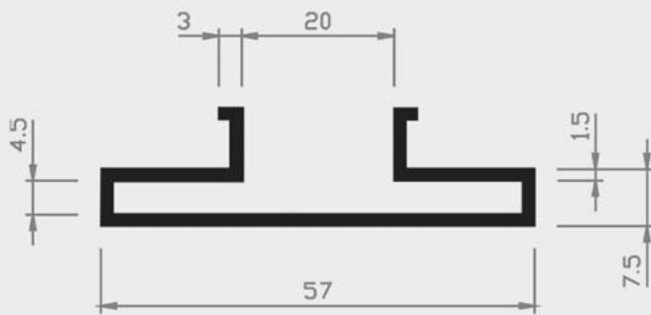

Nr. 13/16 H

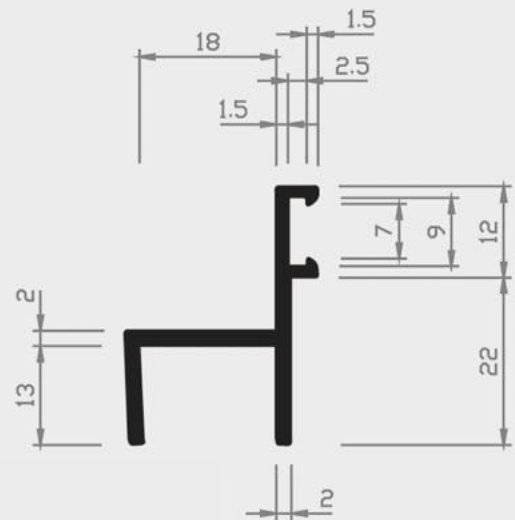

Nr. 18/20 H

= Hart PVC
 = Weich PVC | HH = Halbhart PVC
 = Andere Kunststoffe

20 | SONDERPROFILE

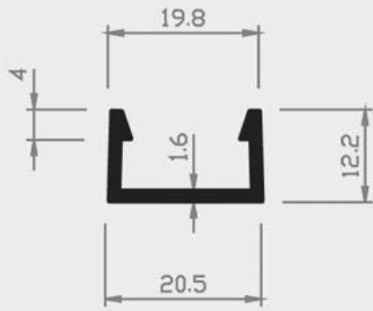

Nr. 16/47 H

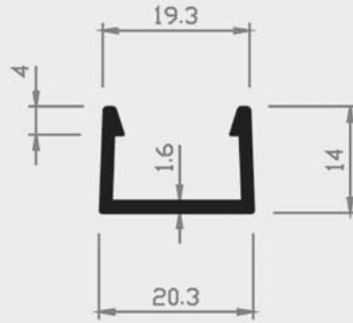

Nr. 16/48 H

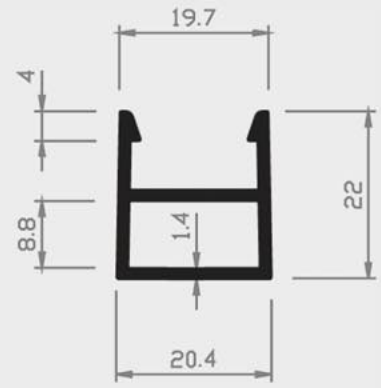

Nr. 16/49 H

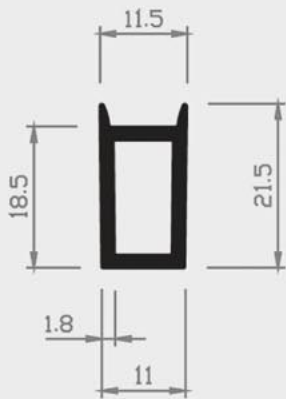

Nr. 14/69 H

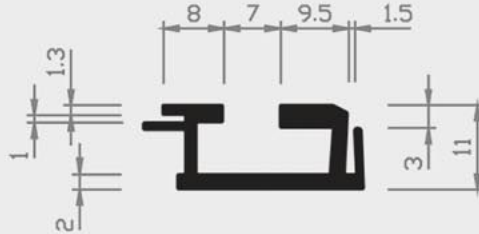

Nr. 24/93 H

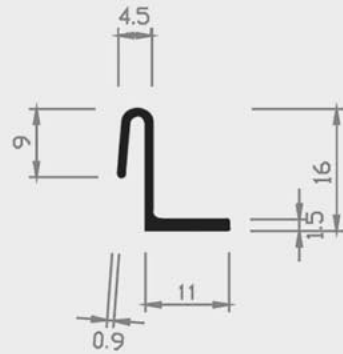

Nr. 24/87 H

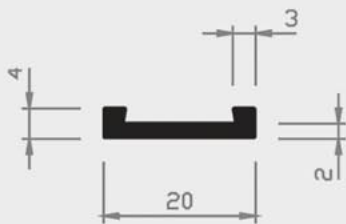

Nr. 13/44a H

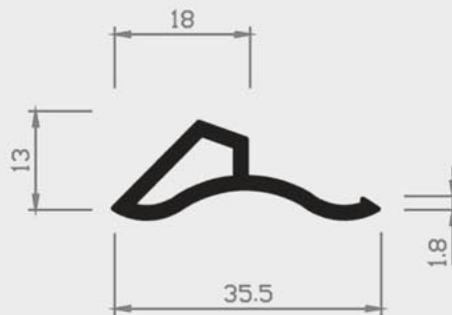

Nr. 14/97 H

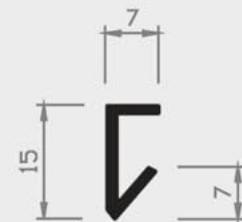

Nr. 29/88 H

= Hart PVC
 = Weich PVC | HH = Halbhart PVC
 = Andere Kunststoffe

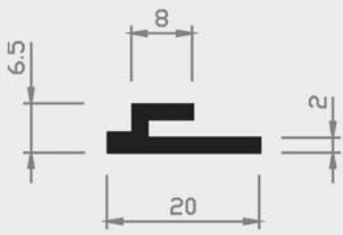

Nr. 15/33 H

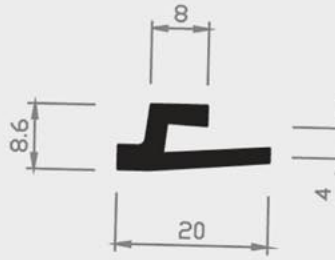

Nr. 15/32 H

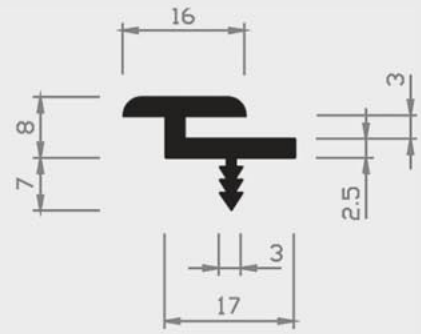

Nr. 19/32 H

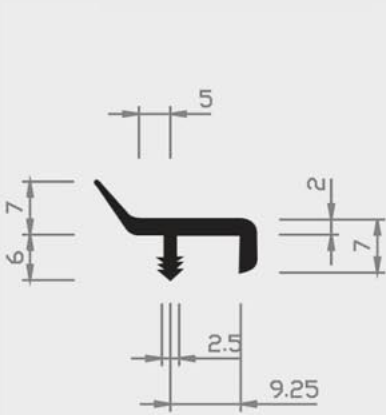

Nr. 12/51 H

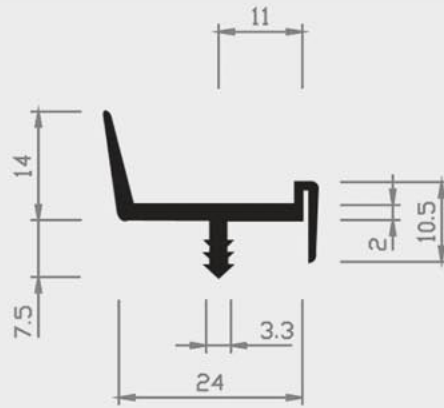

Nr. 13/51 H

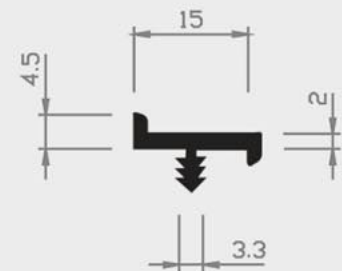

Nr. 15/52 H

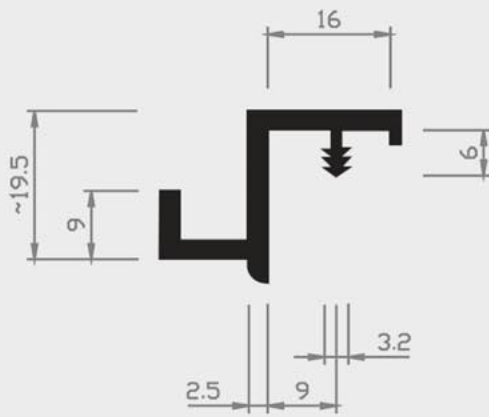

Nr. 13/59 H

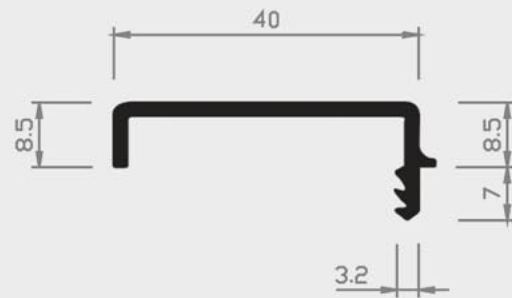

Nr. 28/37 H

= Hart PVC
 = Weich PVC | HH = Halbhart PVC
 = Andere Kunststoffe

20 | SONDERPROFILE

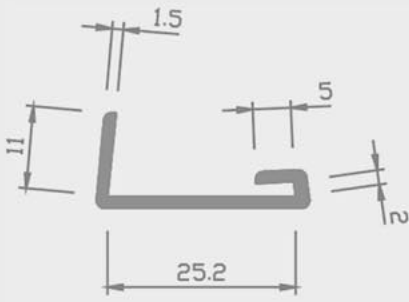

Nr. 12/18 H

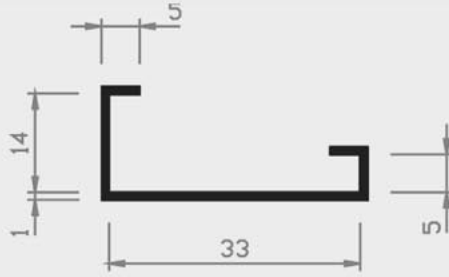

Nr. 16/90 H



Nr. 18/16 H

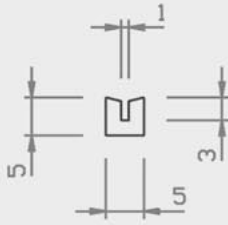

Nr. 6/32 PE

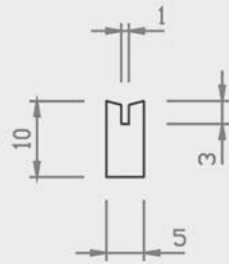

Nr. 6/33 PE

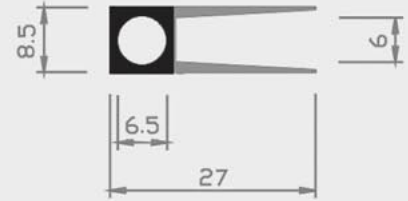

Nr. 31/15 H+W

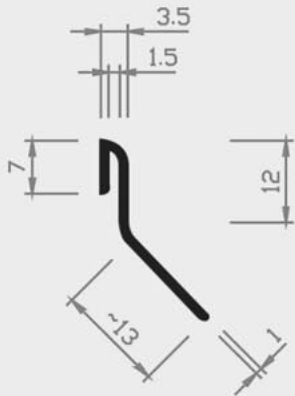

Nr. 36/14 H

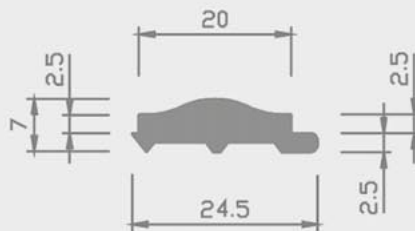

Nr. 44/34 W

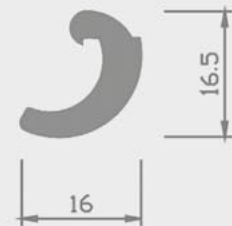

Nr. 17/14 W

■ = Hart PVC

■ = Weich PVC | HH = Halbhart PVC

□ = Andere Kunststoffe

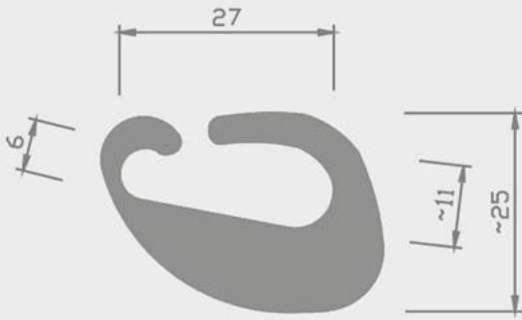

Nr. 14/95 W

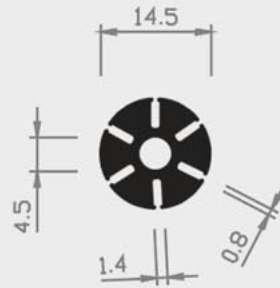

Nr. 50/25 H



Nr. 10/84 W



Nr. 50/14 HH

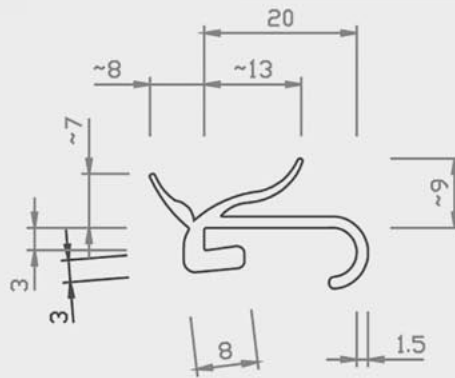

Nr. 12/92 PE



Nr. 15/84 W

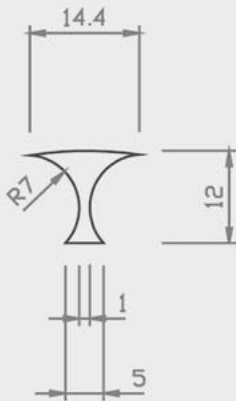

Nr. 16/84 PP
mit Antidehnfaden

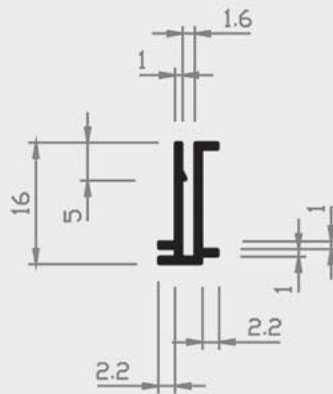

Nr. 16/18 H

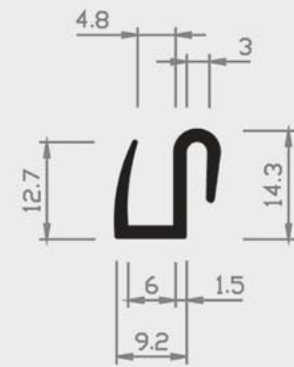

Nr. 18/1 H

■ = Hart PVC ■ = Weich PVC | HH = Halbhart PVC □ = Andere Kunststoffe

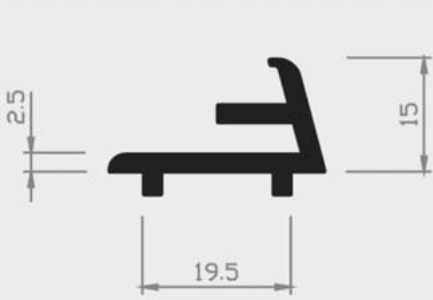

Nr. 17/51 H



Nr. 18/51 H

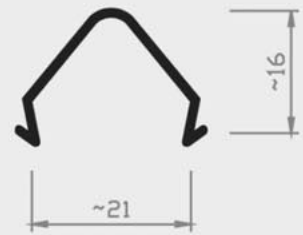

Nr. 16/88 H

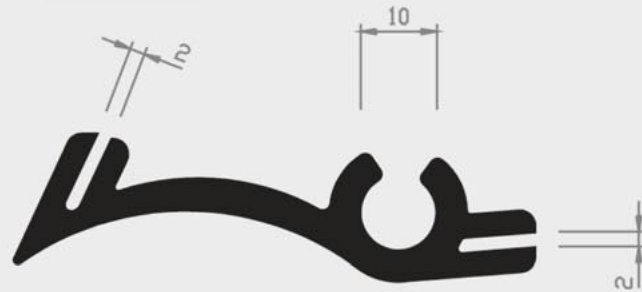

Nr. 14/85 H geschützt

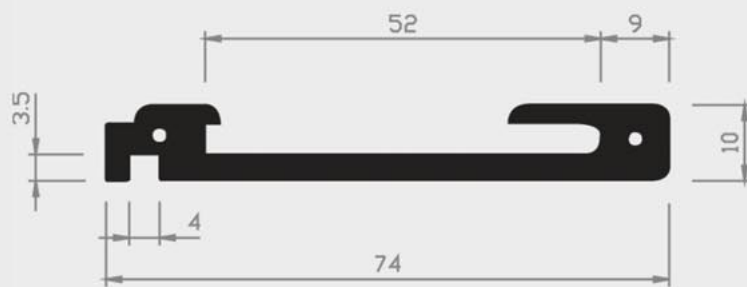

Nr. 18/57 H geschützt

= Hart PVC
 = Weich PVC | HH = Halbhart PVC
 = Andere Kunststoffe

20 | SONDERPROFILE

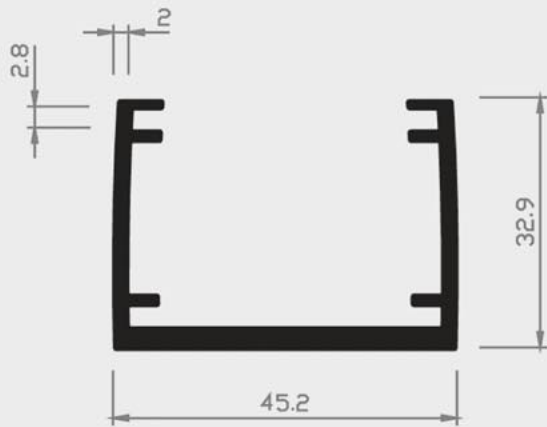

Nr. 29/45 H
geschützt

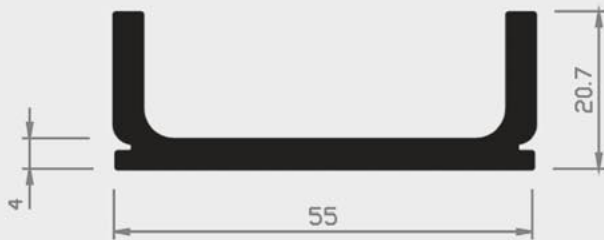

Nr. 30/23 H

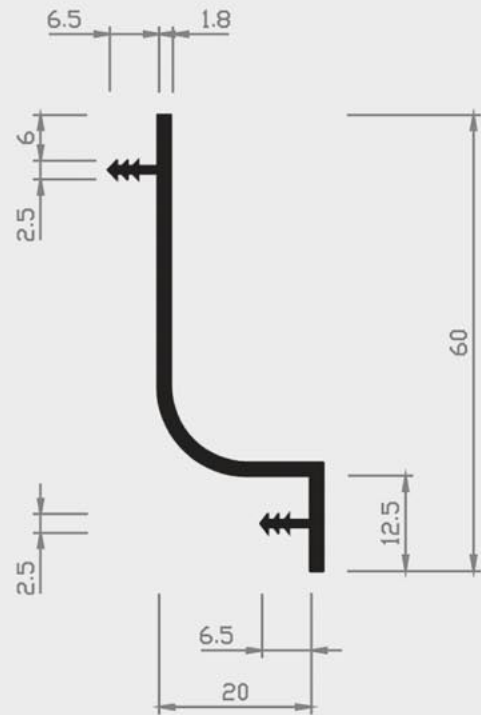

Nr. 11/16 H

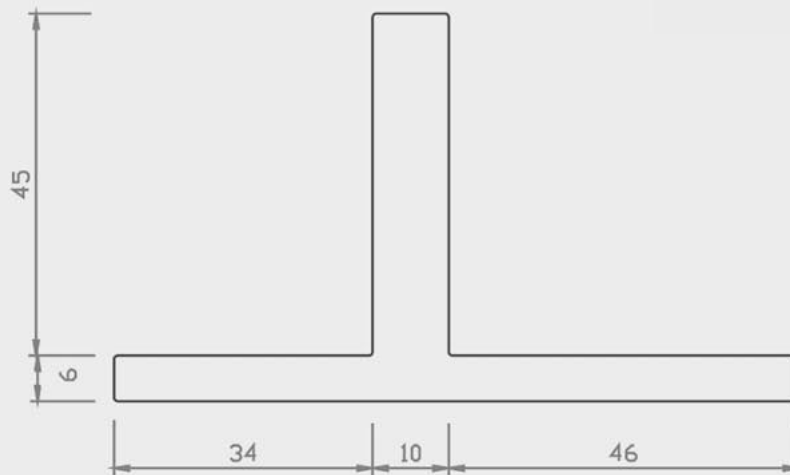

Nr. 25/46 ABS

= Hart PVC
 = Weich PVC | HH = Halbhart PVC
 = Andere Kunststoffe

20 | SONDERPROFILE

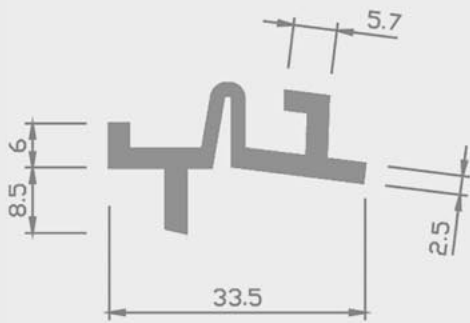

Nr. 41/3 W

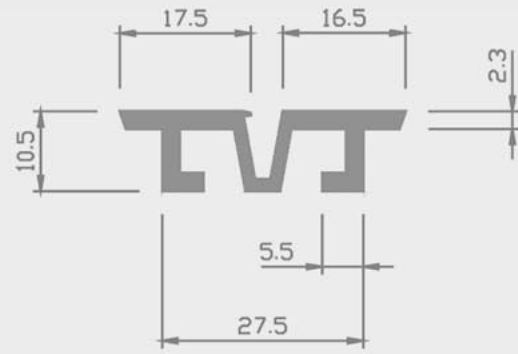

Nr. 41/2 W

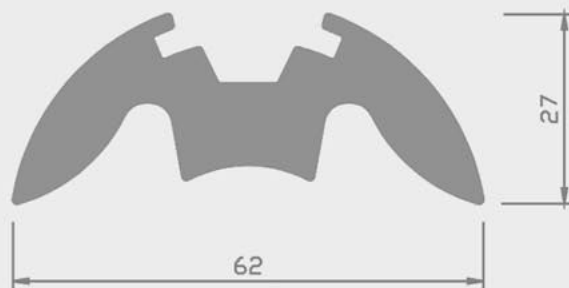

Nr. 52/21 W

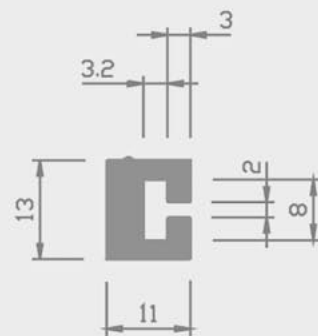

Nr. 46/34 HH

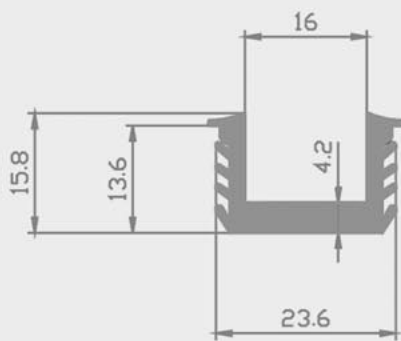

Nr. 28/10 W

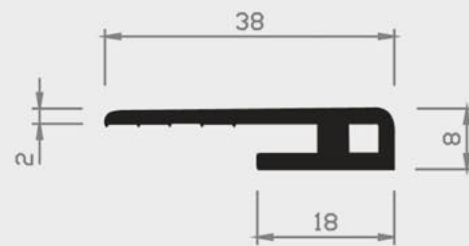

Nr. 18/64 H

= Hart PVC
 = Weich PVC | HH = Halbhart PVC
 = Andere Kunststoffe

20 | SONDERPROFILE

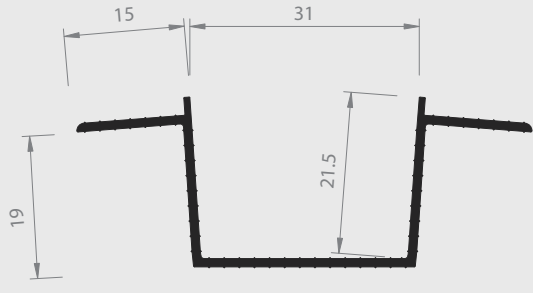

Nr. 23/91a H

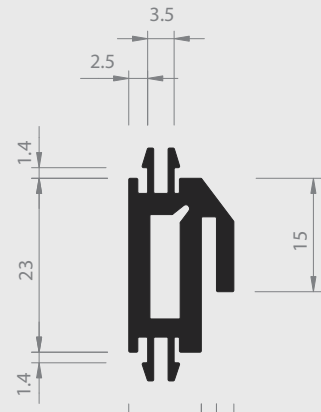

Nr. 13/74 H

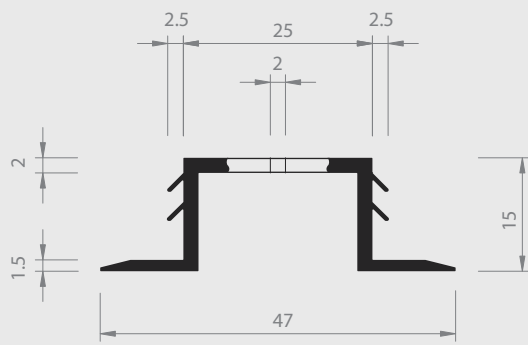
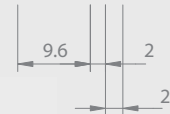

Nr. 24/91 H

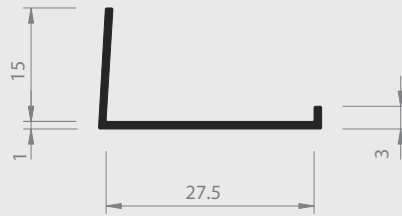

Nr. 19/66 H

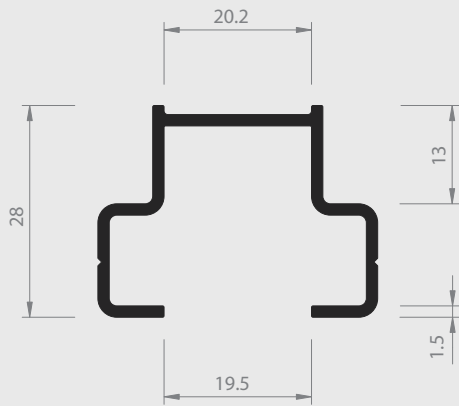

Nr. 24/90 H

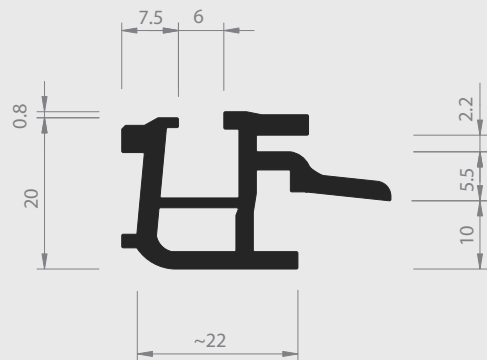

Nr. 24/92 H

= Hart PVC
 = Weich PVC | HH = Halbhart PVC
 = Andere Kunststoffe

20 | SONDERPROFILE

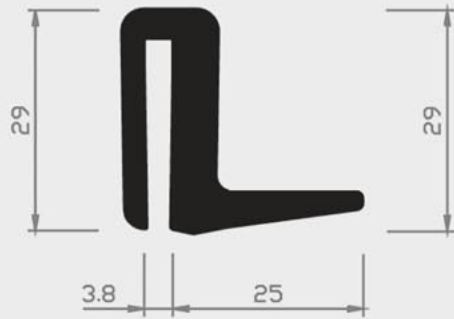

Nr. 26/18 H

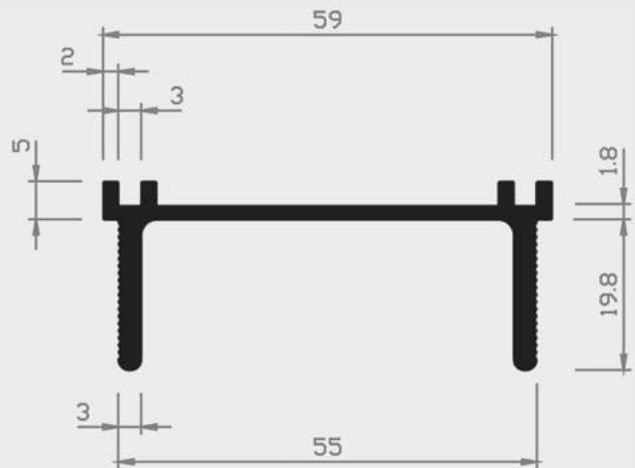

Nr. 18/59 H

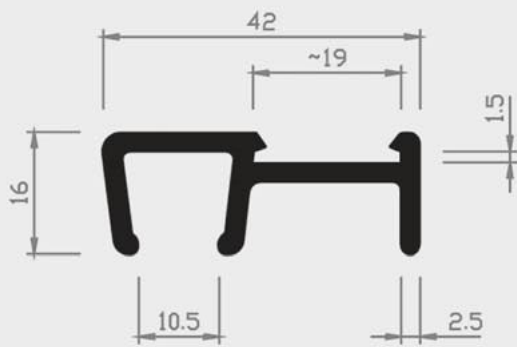

Nr. 18/54 H

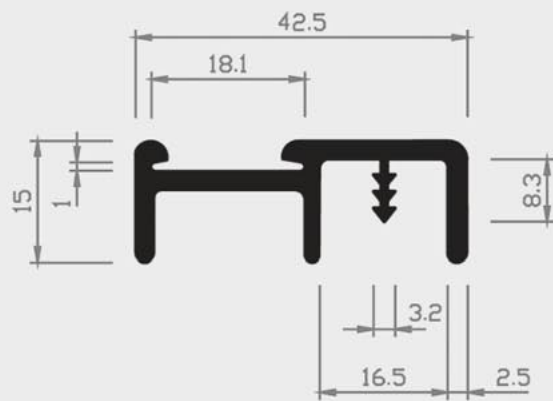

Nr. 18/55 H

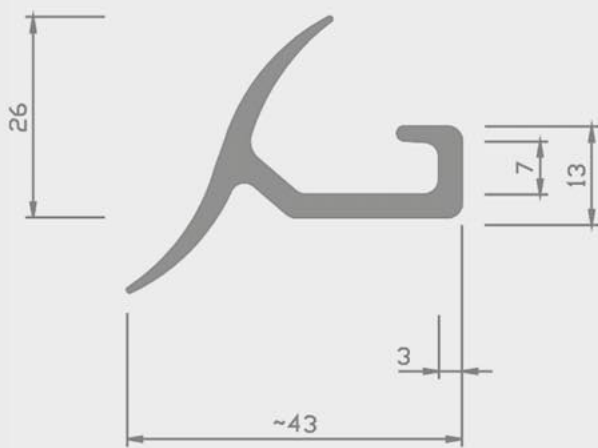

Nr. 13/14 W



Nr. 50/19 W



Nr. 50/26 H

= Hart PVC
 = Weich PVC | HH = Halbhart PVC
 = Andere Kunststoffe

20 | SONDERPROFILE

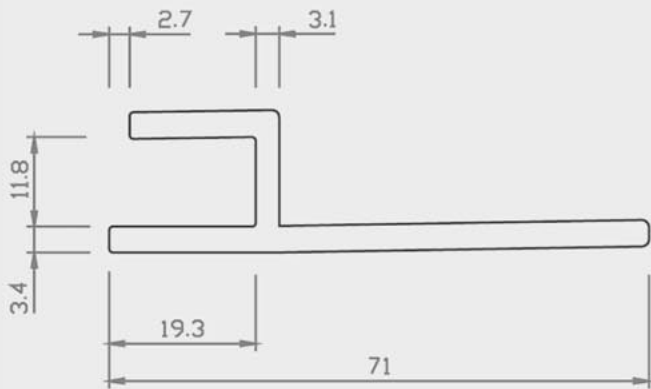

Nr. 22/66 PC geschützt

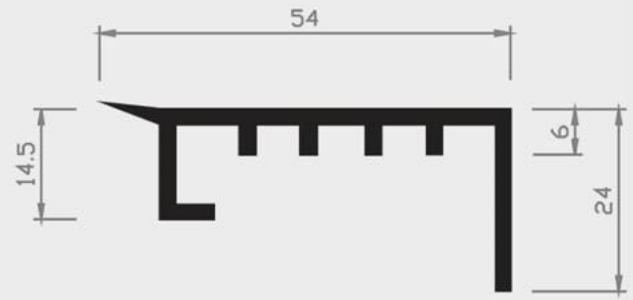

Nr. 11/95 H

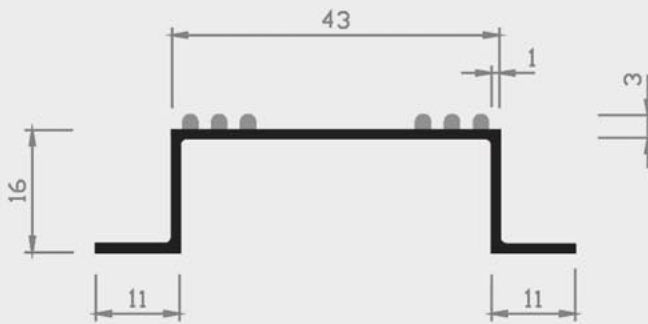

Nr. 24/89 H+W

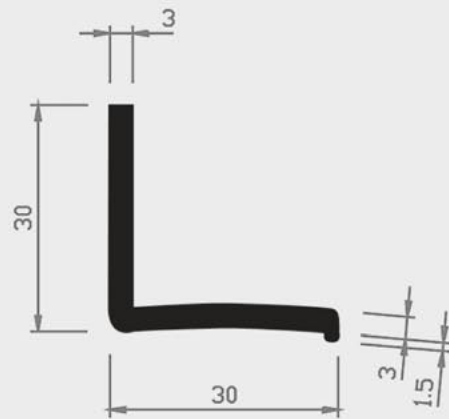

Nr. 1/64 H

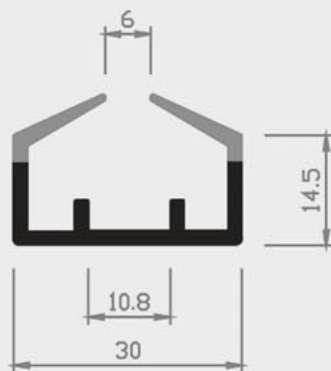

Nr. 28/12 H+W

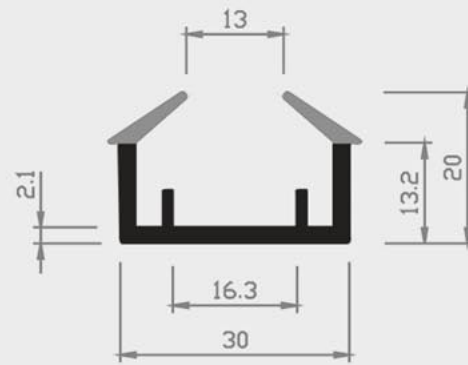

Nr. 28/13 H+W

= Hart PVC
 = Weich PVC | HH = Halbhart PVC
 = Andere Kunststoffe

20 | SONDERPROFILE

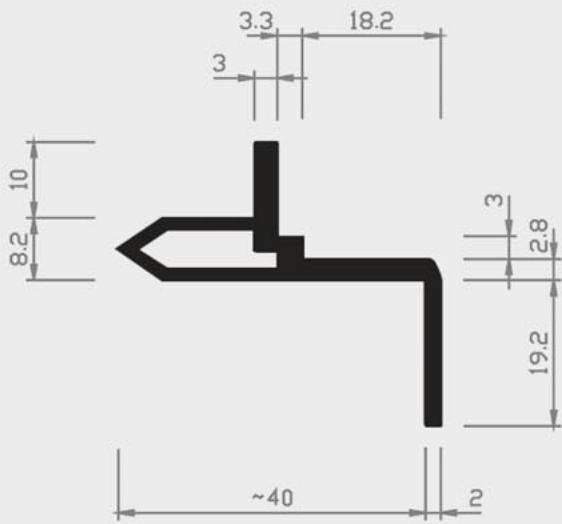

Nr. 14/19 H

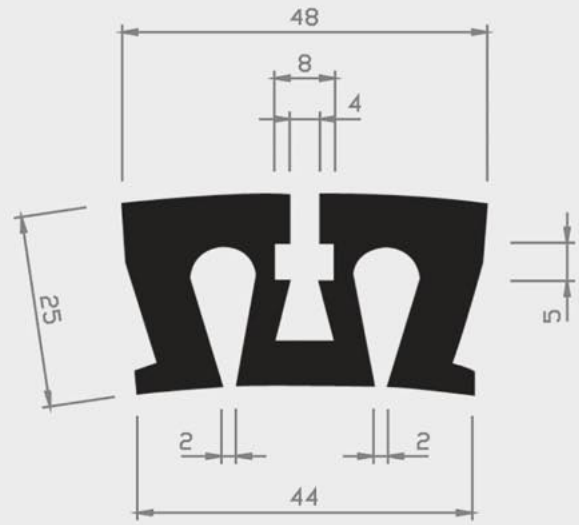

Nr. 62/70 H

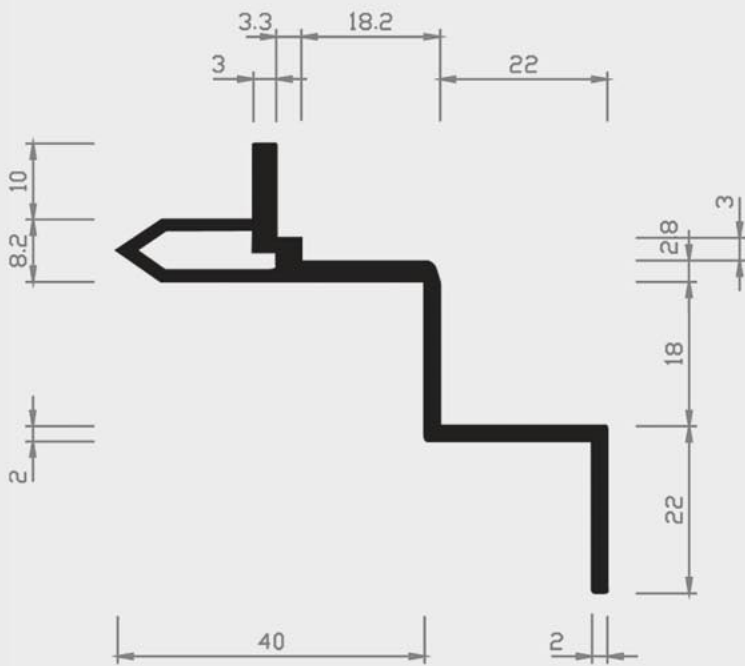

Nr. 14/19a H

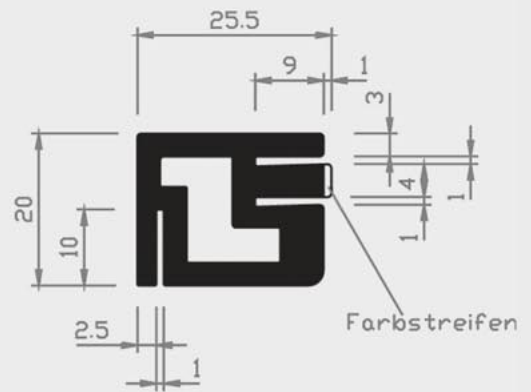

Nr. 24/94 H
zweifärbig

= Hart PVC
 = Weich PVC | HH = Halbhart PVC
 = Andere Kunststoffe

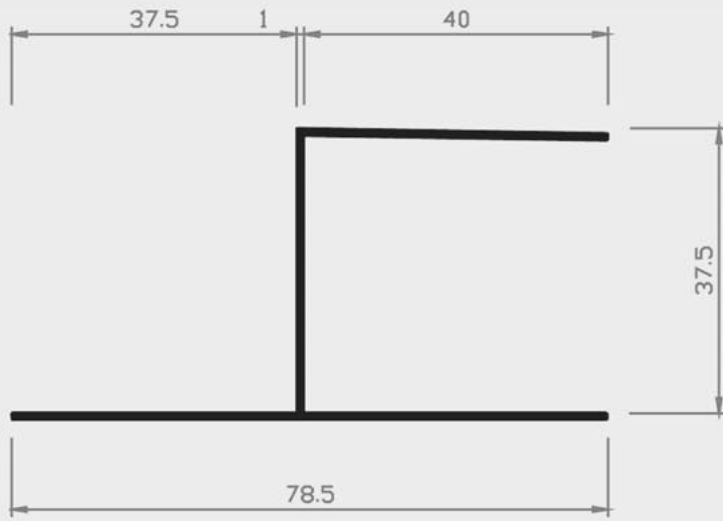

Nr. 18/66 H



Nr. 21/64 H

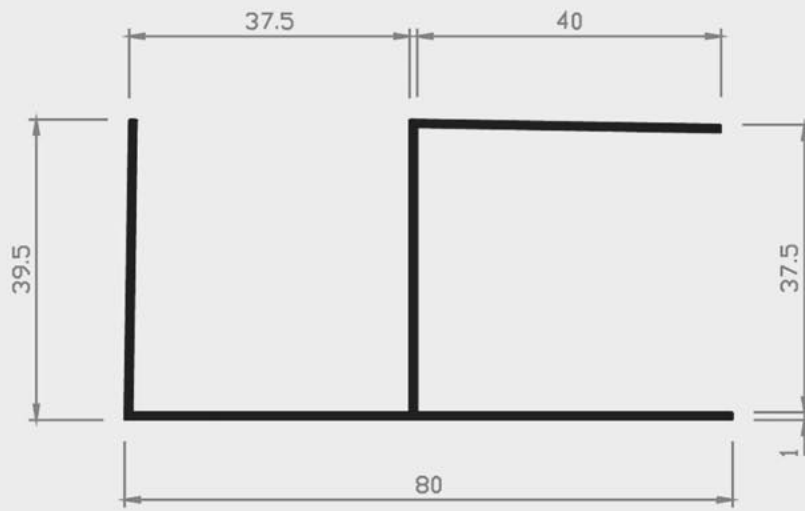

Nr. 17/66 H

= Hart PVC
 = Weich PVC | HH = Halbhart PVC
 = Andere Kunststoffe

20 | SONDERPROFILE

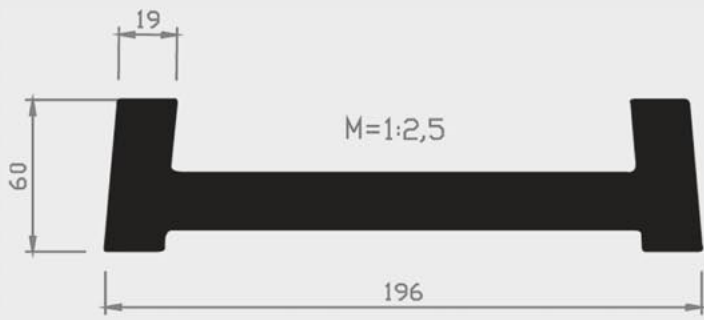

Nr. 40/26 H

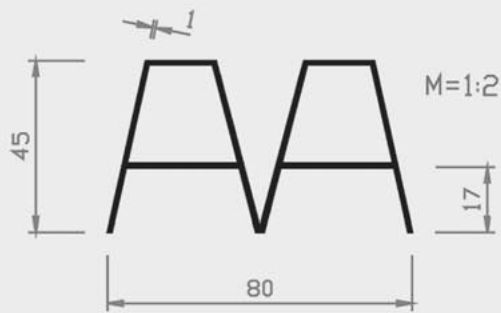

Nr. 62/71 H

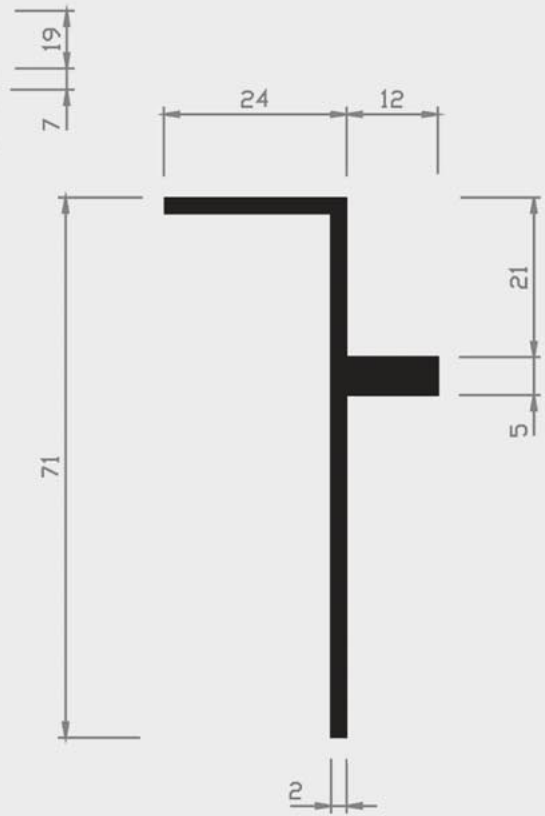

Nr. 29/63 H



Nr. 40/28 H

= Hart PVC
 = Weich PVC | HH = Halbhart PVC
 = Andere Kunststoffe

20 | SONDERPROFILE

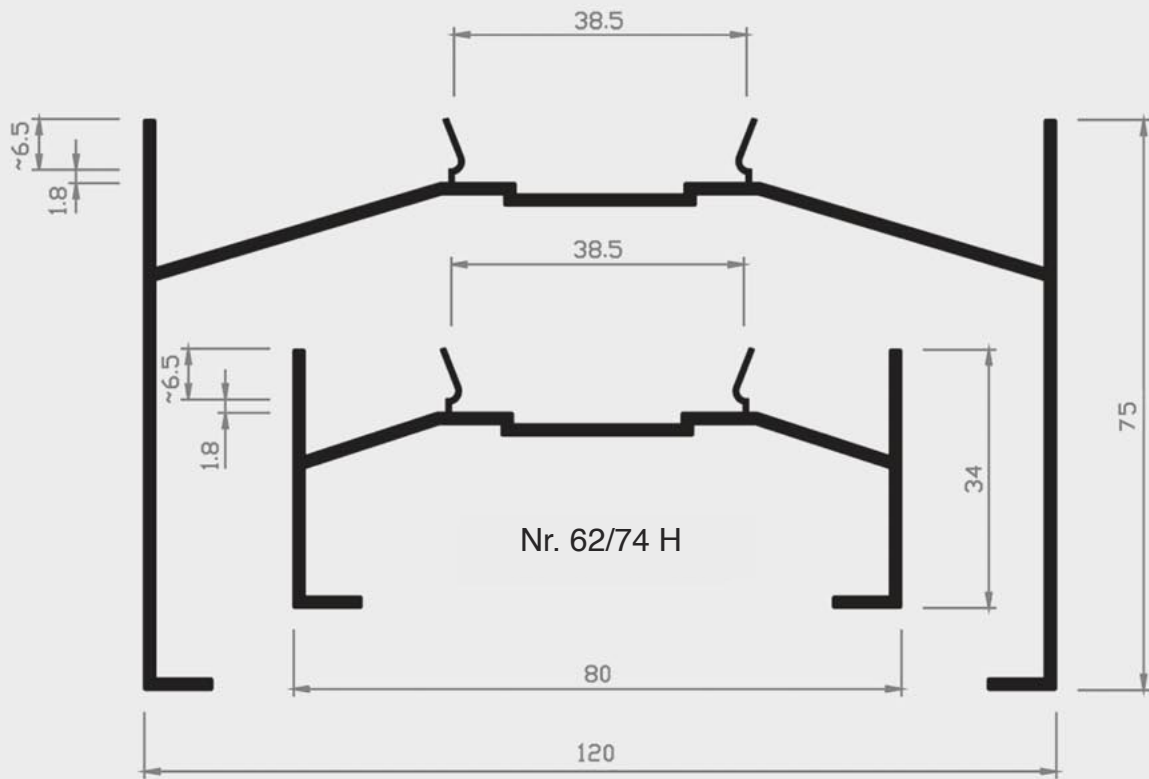

Nr. 62/75 H

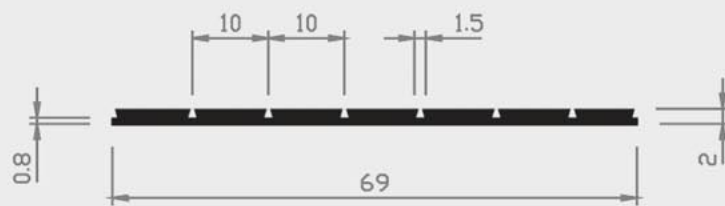

Nr. 21/92 H

= Hart PVC
 = Weich PVC | HH = Halbhart PVC
 = Andere Kunststoffe

20 | SONDERPROFILE

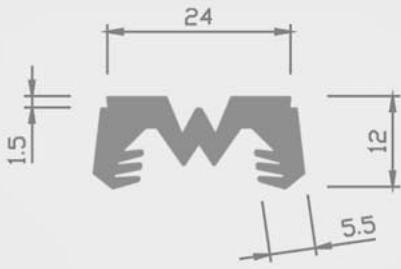

Nr. 40/1 W

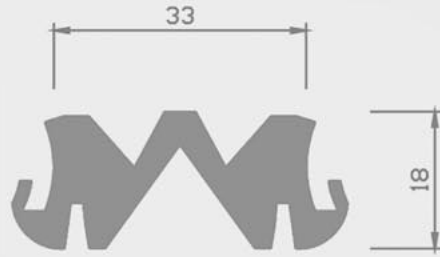

Nr. 41/1 W

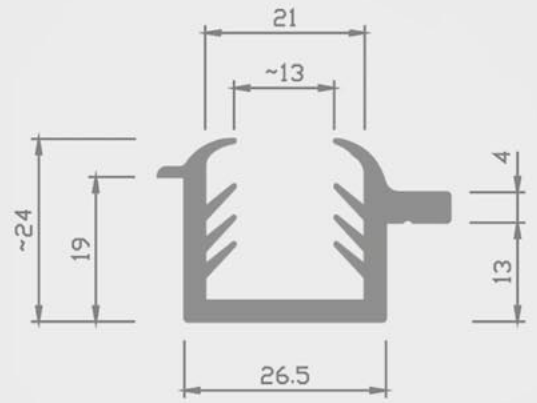

Nr. 45/34 W

Nr. 65/60 W

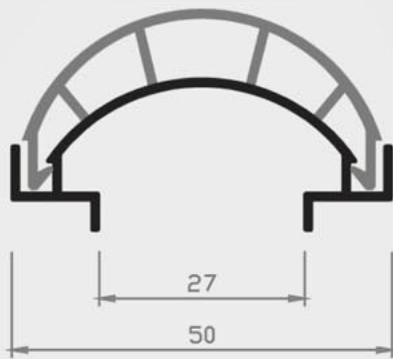

Nr. 64/60 H

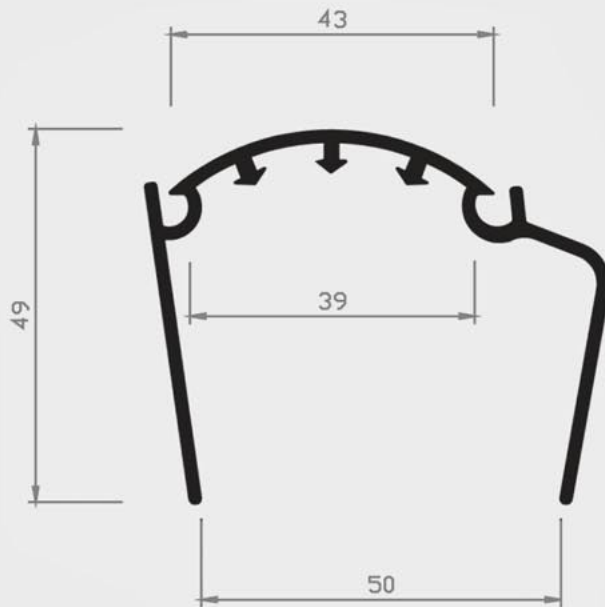

Nr. 64/61 H

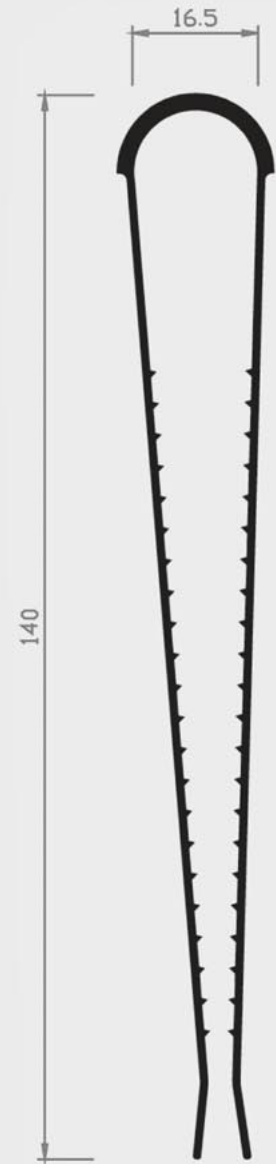

Nr. 15/85 H

= Hart PVC
 = Weich PVC | HH = Halbhart PVC
 = Andere Kunststoffe

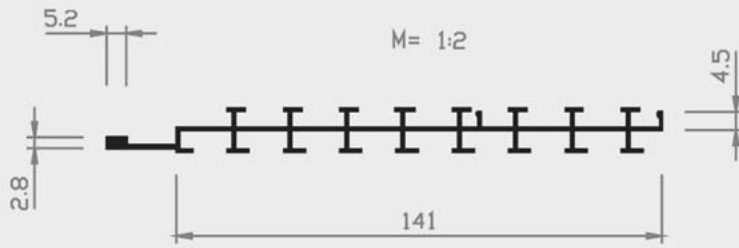

Nr. 4/26 H
geschützt

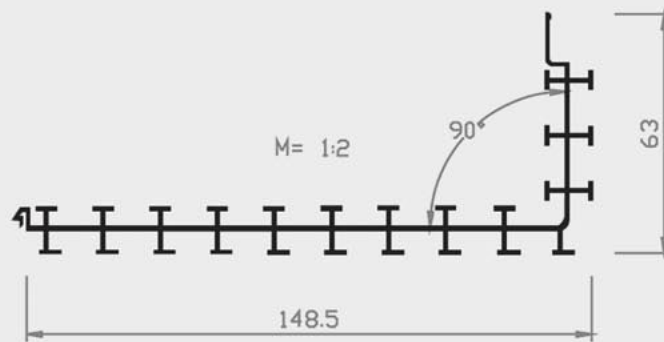

Nr. 4/25 H
geschützt

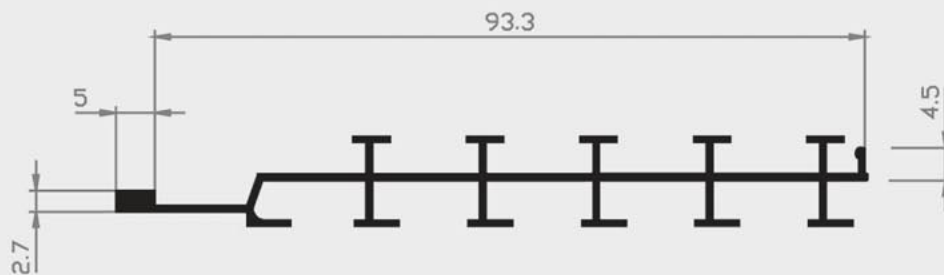

Nr. 4/27 H
geschützt

= Hart PVC
 = Weich PVC | HH = Halbhart PVC
 = Andere Kunststoffe

20 | SONDERPROFILE

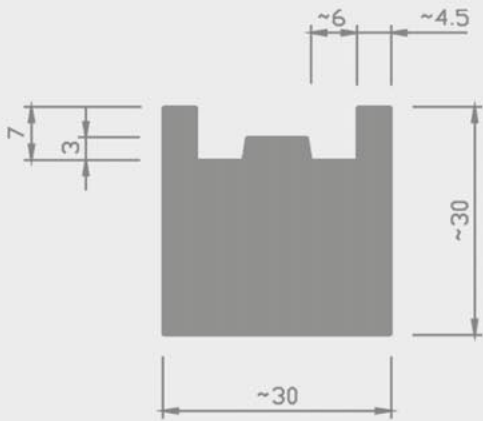

Nr. 61/74 W

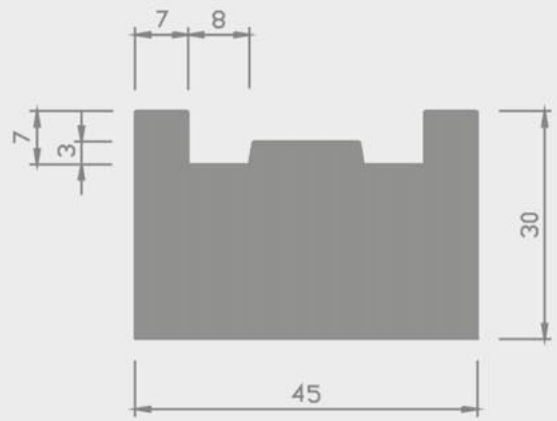

Nr. 61/76 W

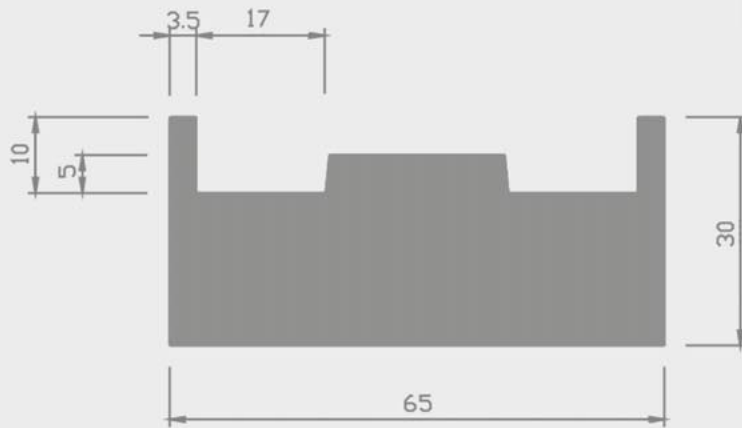

Nr. 61/75 W

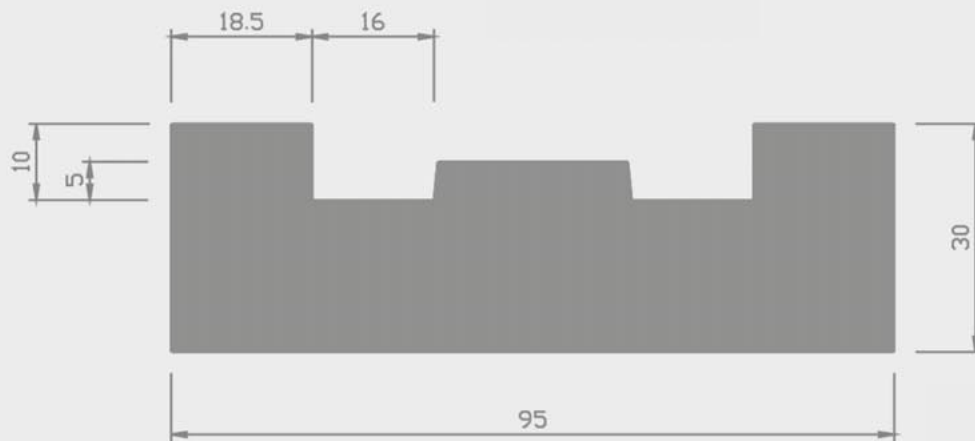

Nr. 61/77 W

= Hart PVC
 = Weich PVC | HH = Halbhart PVC
 = Andere Kunststoffe

20 | SONDERPROFILE

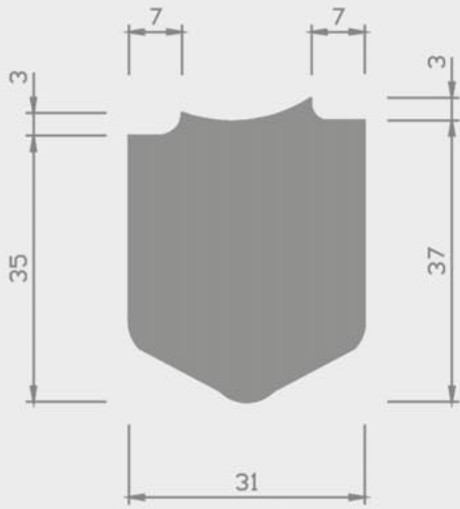

Nr. 61/70 W

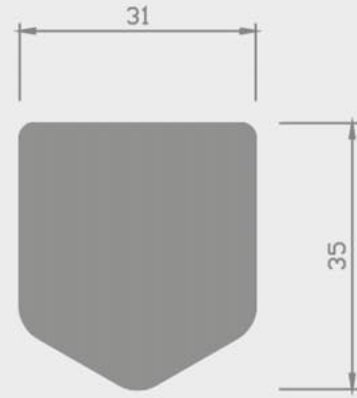

Nr. 61/71 W

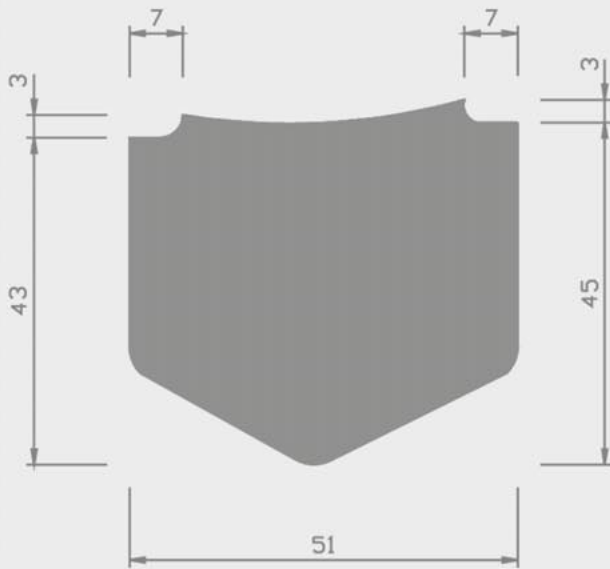

Nr. 61/72a W

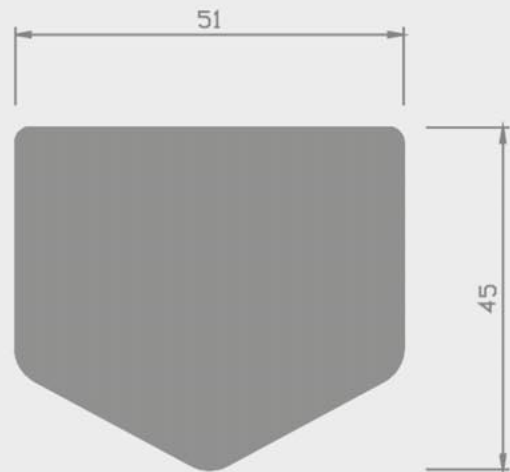

Nr. 61/73a W

■ = Hart PVC ■ = Weich PVC | HH = Halbhart PVC □ = Andere Kunststoffe

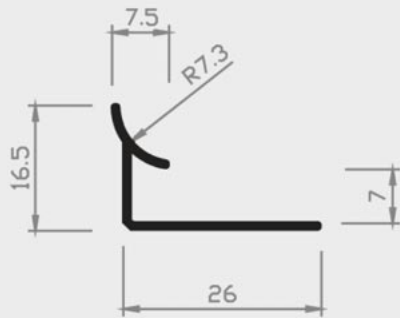

Nr. 26/3 H
geschützt

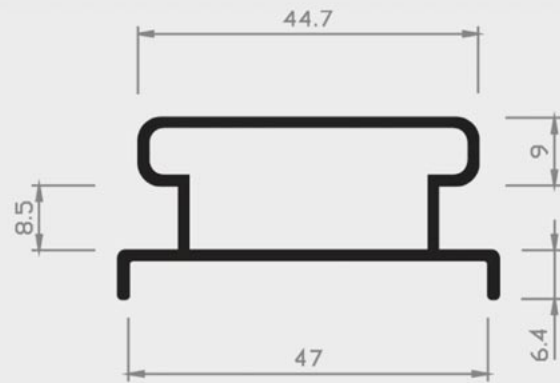

Nr. 61/78 W

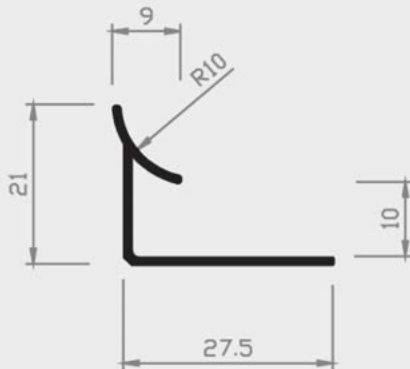

Nr. 26/4 H
geschützt

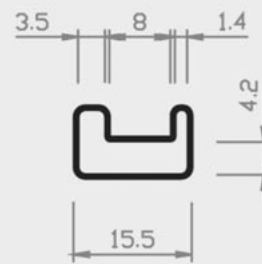

Nr. 62/69 H
geschützt

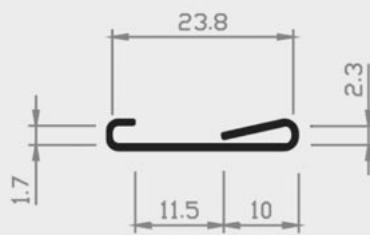

Nr. 27/90 H

= Hart PVC
 = Weich PVC | HH = Halbhart PVC
 = Andere Kunststoffe

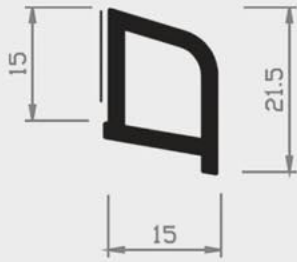

Nr. 35/15 H
geschützt
selbstklebend

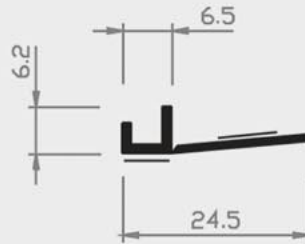

Nr. 25/95 H
selbstklebend

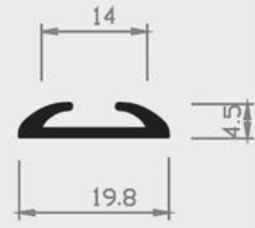

Nr. 8/91 H

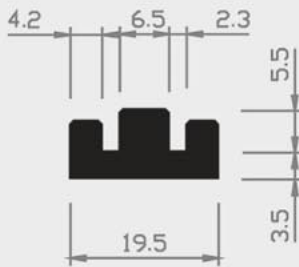

Nr. 25/9 H

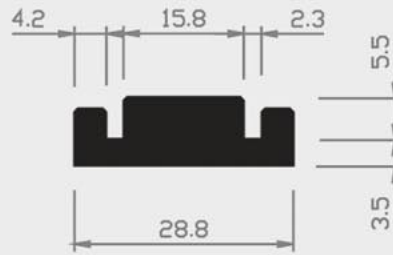

Nr. 25/10 H

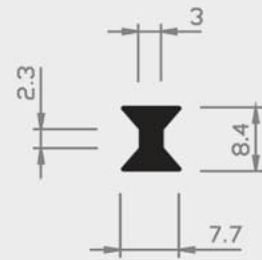

Nr. 8/29 H

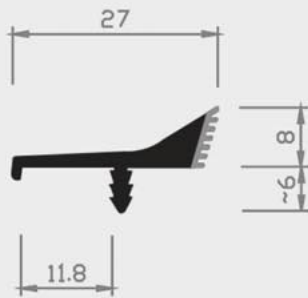

Nr. 60/37 HH+W



Nr. 60/38 HH+W

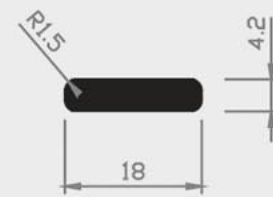

Nr. 8/45 H

■ = Hart PVC ■ = Weich PVC | HH = Halbhart PVC □ = Andere Kunststoffe

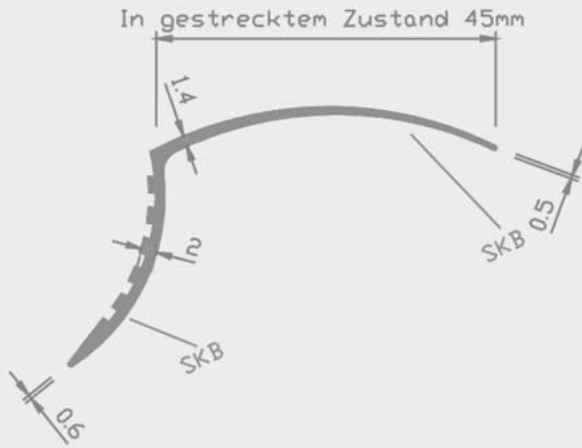

Nr. 18/92 W

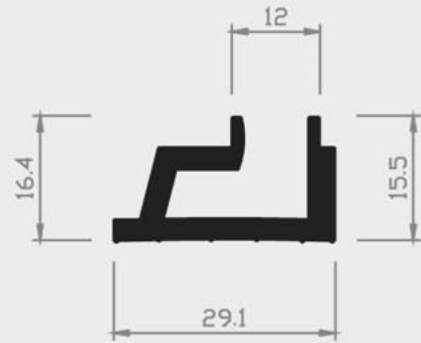

Nr. 21/16 H

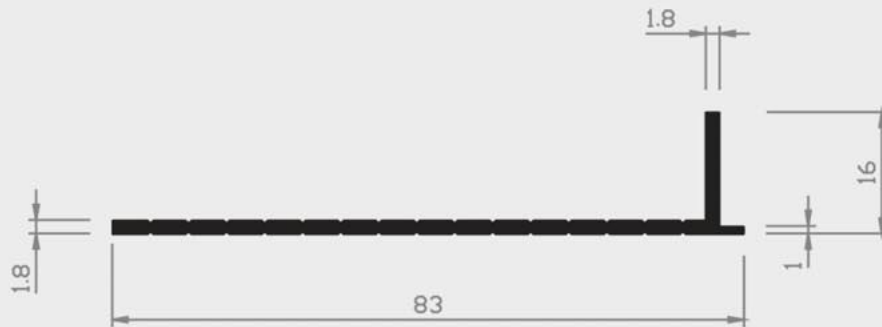

Nr. 30/26 H
geschützt

= Hart PVC
 = Weich PVC | HH = Halhart PVC
 = Andere Kunststoffe

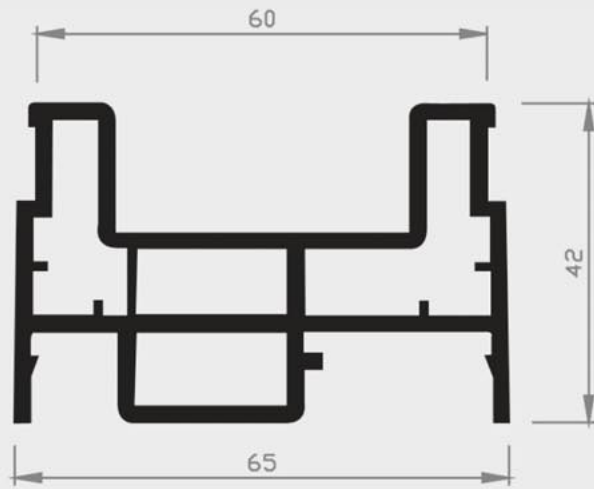

Nr. 22/94 H
geschützt

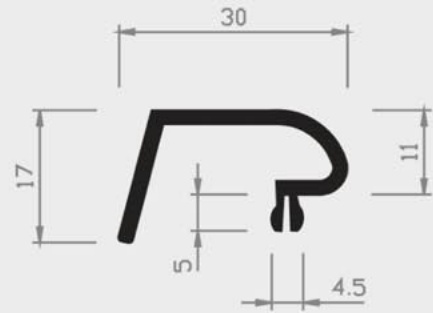

Nr. 23/67 H

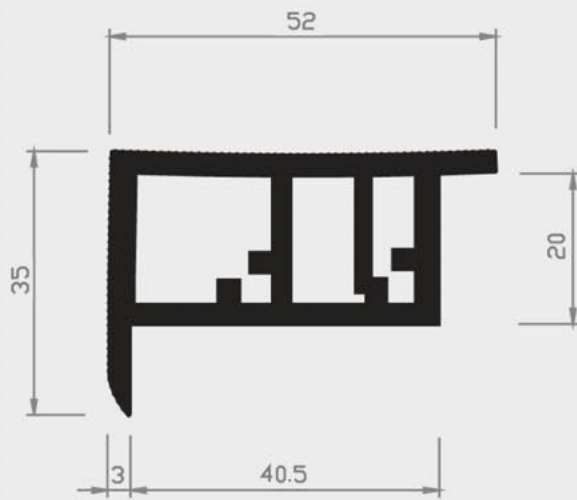

Nr. 25/7 H

= Hart PVC
 = Weich PVC | HH = Halbhart PVC
 = Andere Kunststoffe

20 | SONDERPROFILE

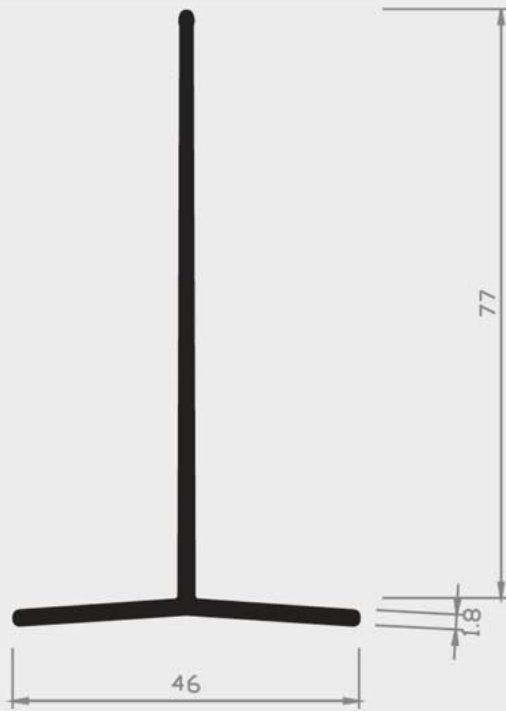

Nr. 31/25 H

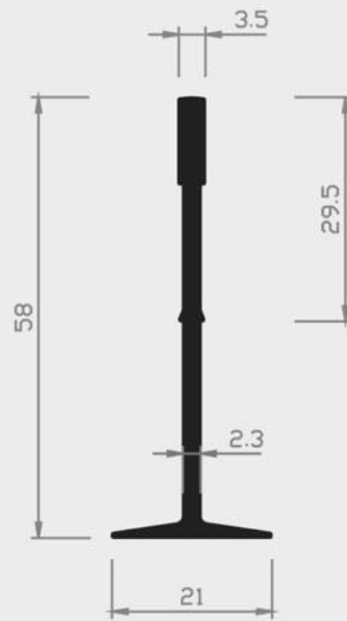

Nr. 30/21 H

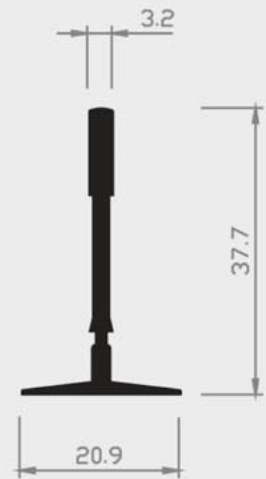

Nr. 31/21 H

Nr. 5/30 ABS

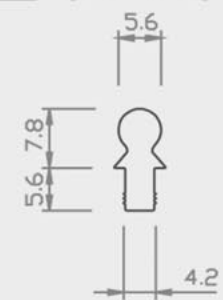
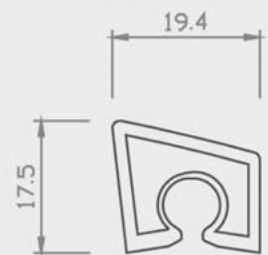

Nr. 5/31 ABS

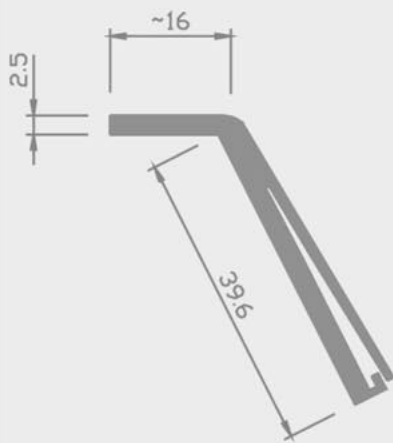

Nr. 9/89 HH+W

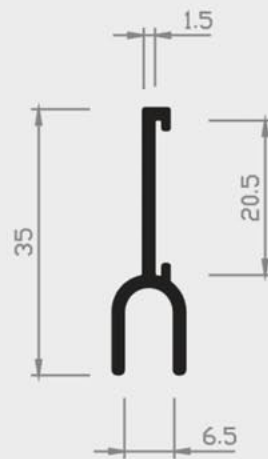

Nr. 5/39 H

= Hart PVC
 = Weich PVC | HH = Halhart PVC
 = Andere Kunststoffe

20 | SONDERPROFILE

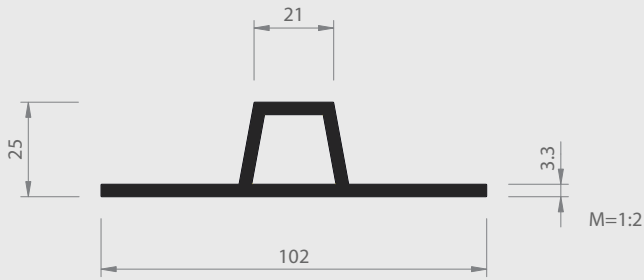

Nr. 62/79 H

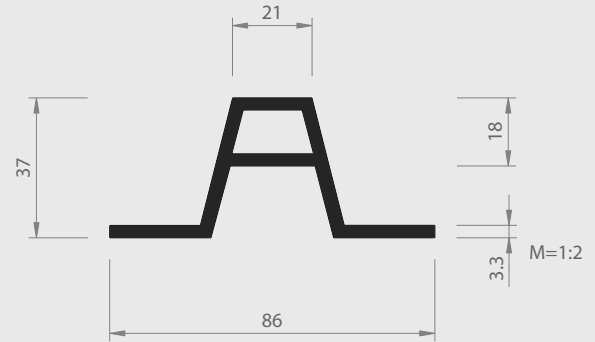

Nr. 62/78 H

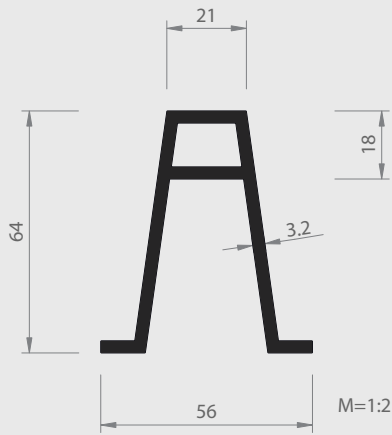

Nr. 62/76 H

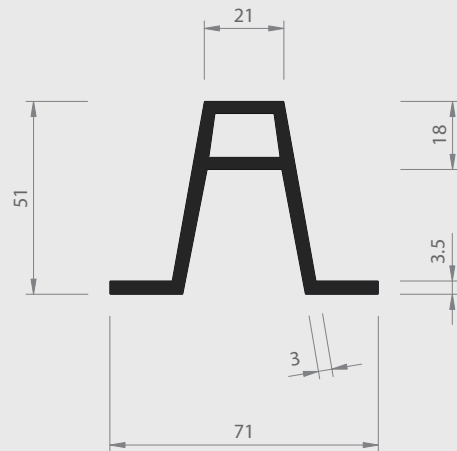

Nr. 62/77 H

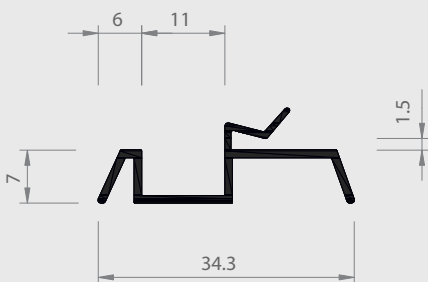

Nr. 27/69 H

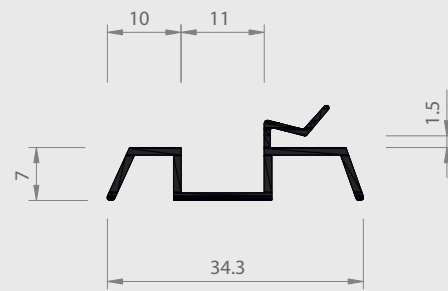

Nr. 27/69a H

= Hart PVC
 = Weich PVC | HH = Halbhart PVC
 = Andere Kunststoffe

20 | SONDERPROFILE

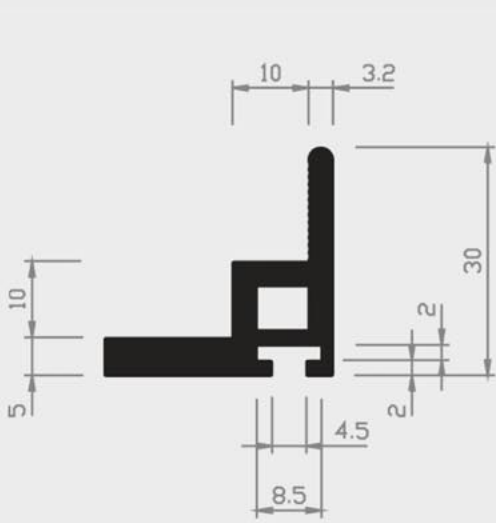

Nr. 30/5 H

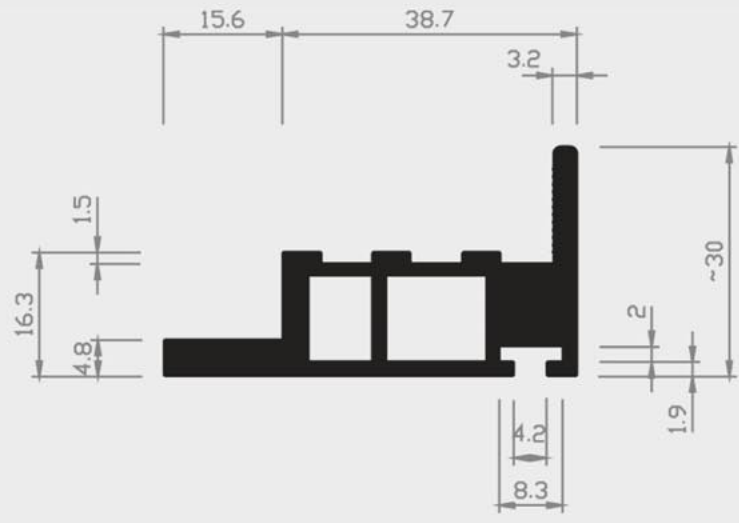

Nr. 30/2 H



Nr. 30/6 H

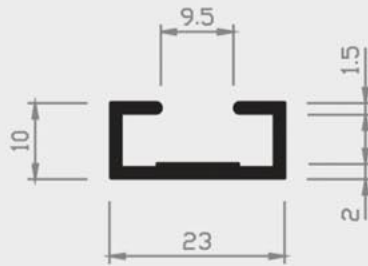

Nr. 30/7 H

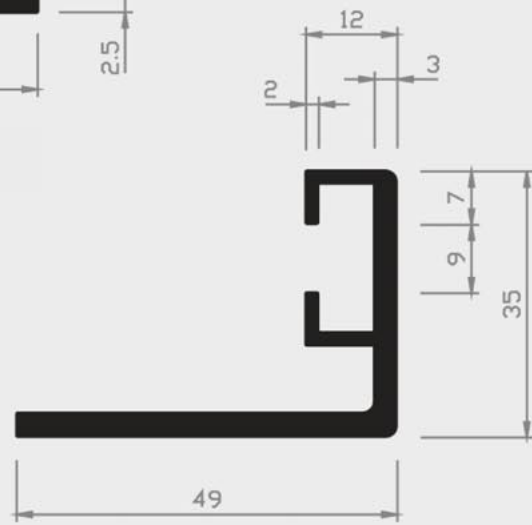

Nr. 30/8 H

= Hart PVC
 = Weich PVC | HH = Halbhart PVC
 = Andere Kunststoffe

20 | SONDERPROFILE

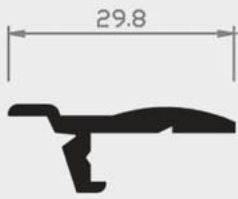

Nr. 15/76 H
geschützt

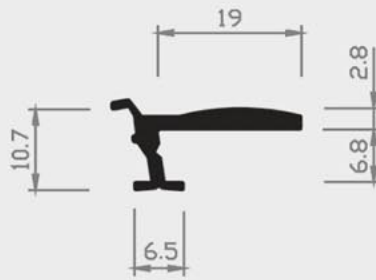

Nr. 15/79 H
geschützt

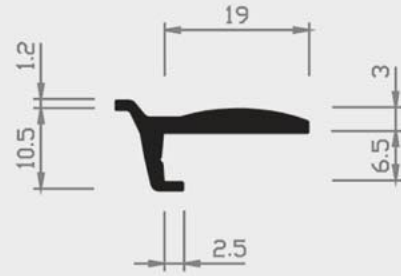

Nr. 15/80 H
geschützt

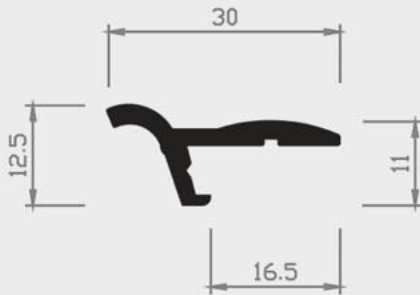

Nr. 16/76 H
geschützt

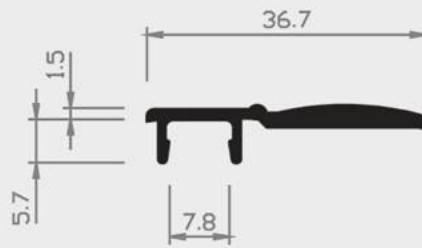

Nr. 14/79 H
geschützt

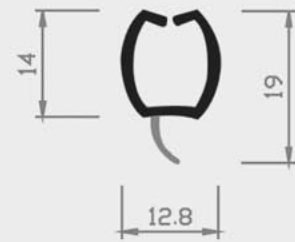

Nr. 15/81 H+W
geschützt

Nr. 13/69 H
geschützt

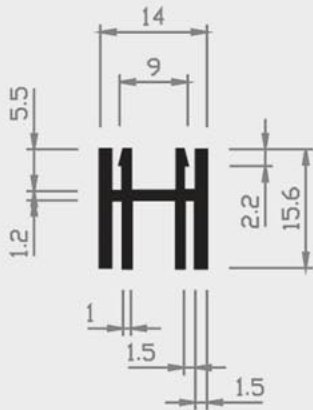

Nr. 13/70 H
geschützt

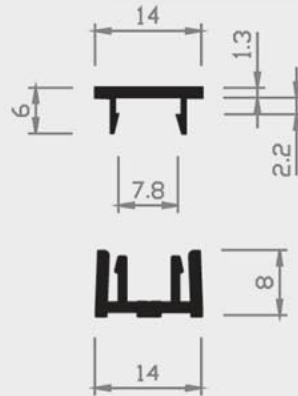

Nr. 18/70 H
geschützt

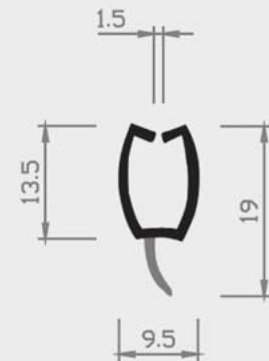

Nr. 16/81 H+W
geschützt

■ = Hart PVC

■ = Weich PVC | HH = Halbhart PVC

□ = Andere Kunststoffe

Nr. 14/75 H
geschützt

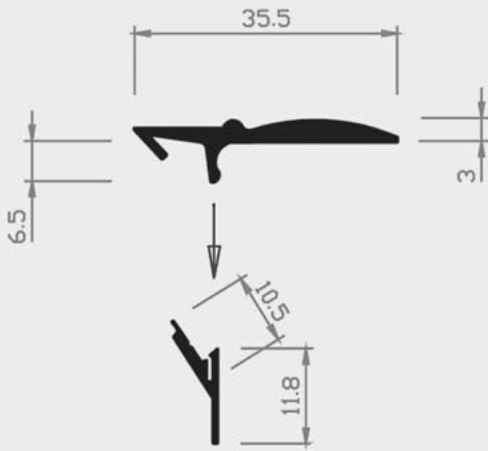

Nr. 14/74 H
geschützt

Nr. 15/75 H
geschützt

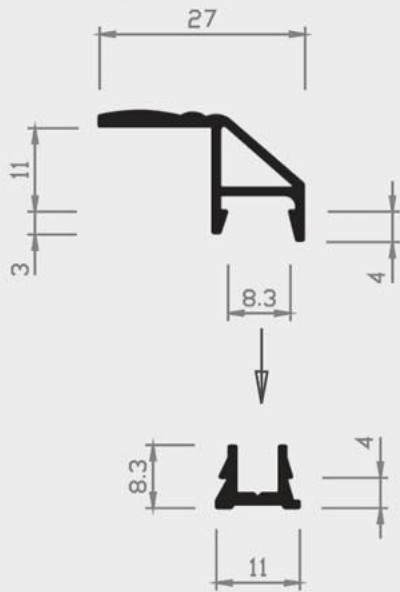

Nr. 15/74 H
geschützt

Nr. 14/76 H
geschützt

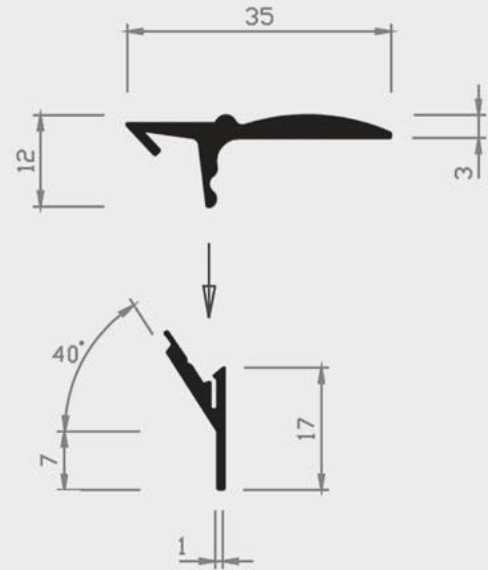

Nr. 14/77 H
geschützt

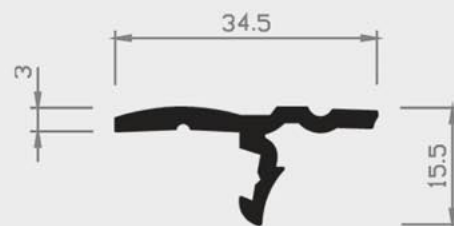

Nr. 16/79 H
geschützt

= Hart PVC
 = Weich PVC | HH = Halbhart PVC
 = Andere Kunststoffe

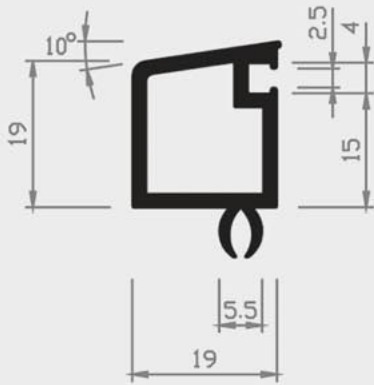

Nr. 60/4 H

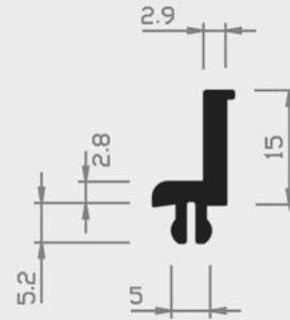

Nr. 26/70 H

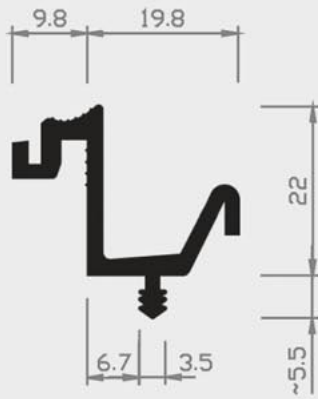

Nr. 35/38 H
geschützt

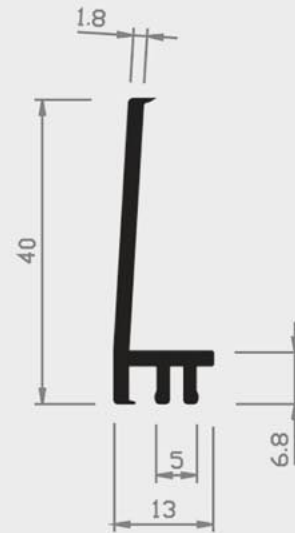

Nr. 26/69 H

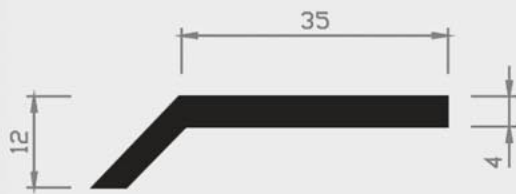

Nr. 9/18 H

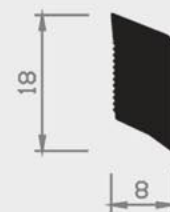

Nr. 24/96 H

= Hart PVC
 = Weich PVC | HH = Halbhart PVC
 = Andere Kunststoffe

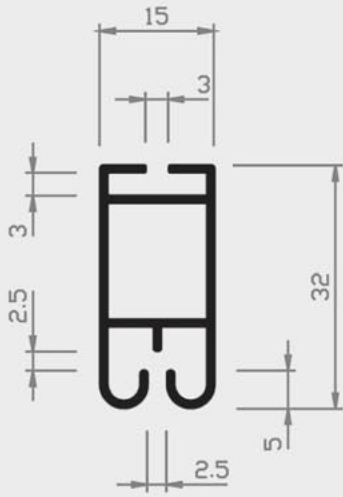

Nr. 15/82 H
geschützt

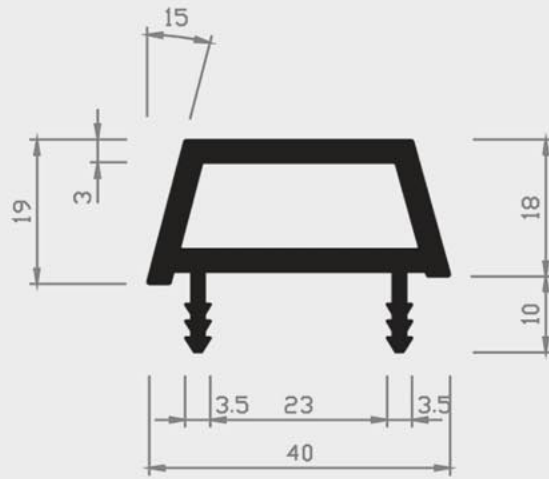

Nr. 21/91 H

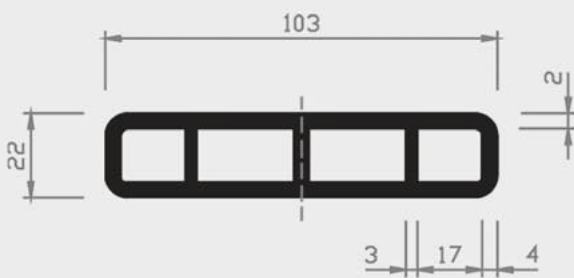

M 1:2

Nr. 30/4 H

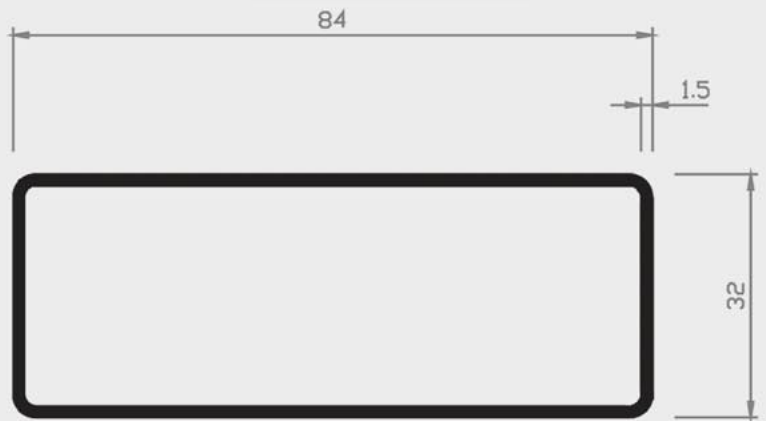

Nr. 31/4 H
geschützt

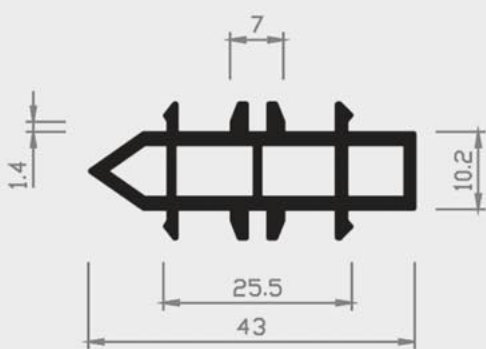

Nr. 60/7 H

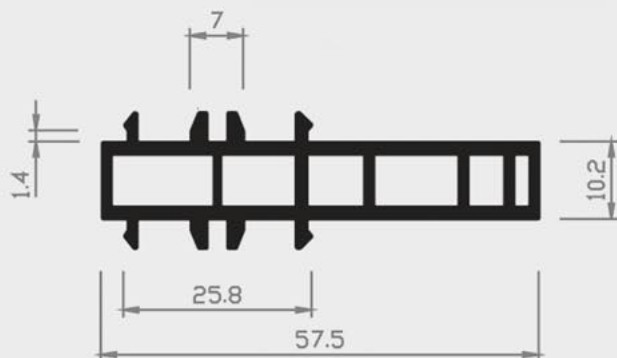

Nr. 60/6 H

■ = Hart PVC ■ = Weich PVC | HH = Halbhart PVC □ = Andere Kunststoffe

20 | SONDERPROFILE

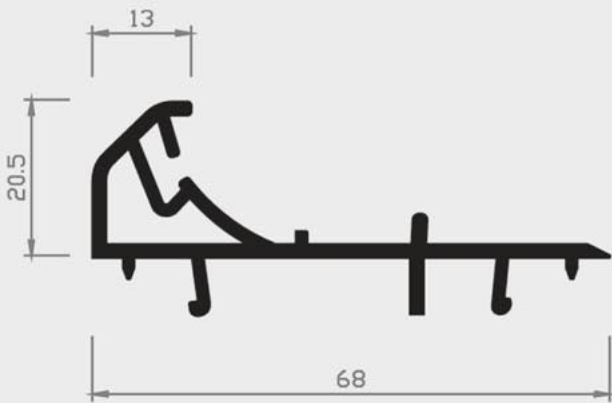

Nr. 25/96 H
geschützt

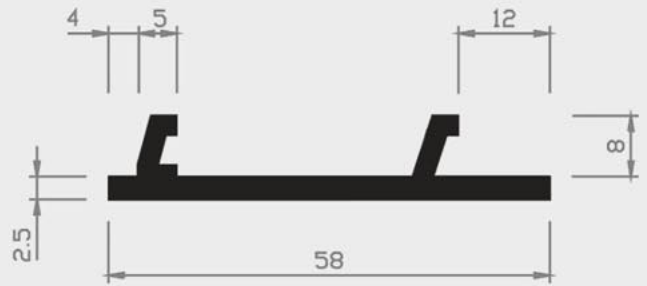

Nr. 21/95a H

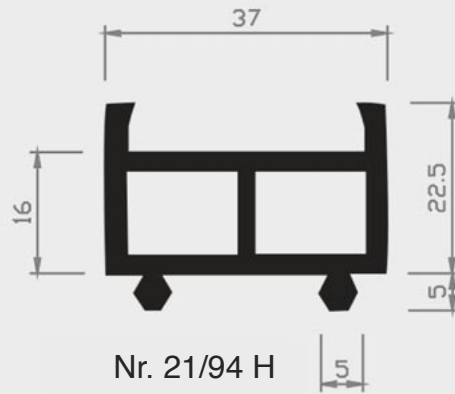

Nr. 21/94 H

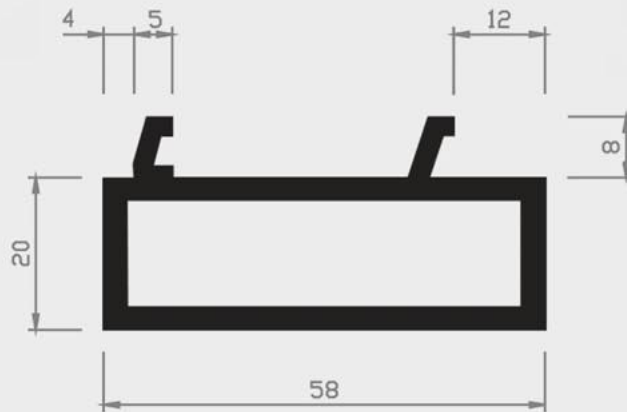

Nr. 21/95 H

= Hart PVC
 = Weich PVC | HH = Halbhart PVC
 = Andere Kunststoffe

20 | SONDERPROFILE

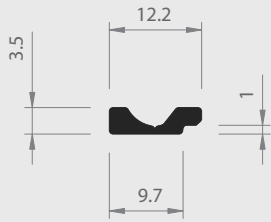

Nr. 01/59 H

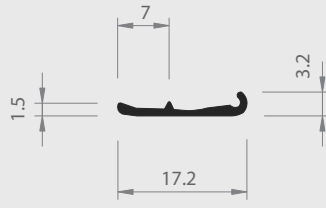

Nr. 02/65 H

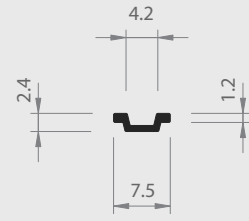

Nr. 23/29 H

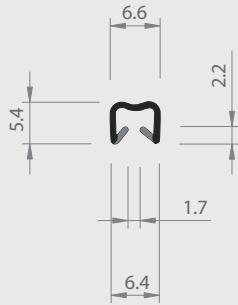

Nr. 16/80 H+W

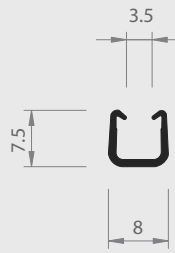

Nr. 16/82 H

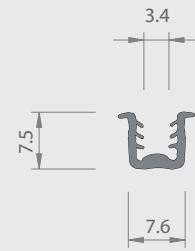

Nr. 40/42 H

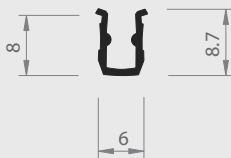

Nr. 22/62 H

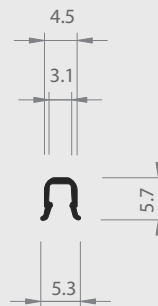

Nr. 22/64 H

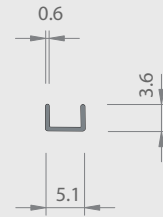

Nr. 60/36 W

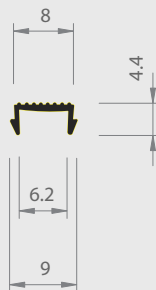

Nr. 14/65 H

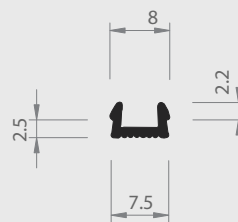

Nr. 15/65 H

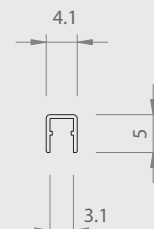

Nr. 04/37 PE

= Hart PVC
 = Weich PVC | HH = Halbhart PVC
 = Andere Kunststoffe

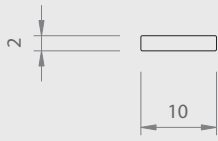

Nr. 20/02 ABS



Nr. 01/74 HH

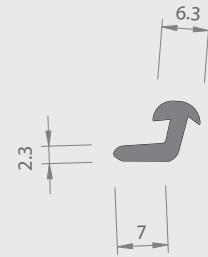

Nr. 09/47 HH

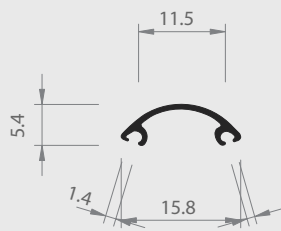

Nr. 04/22 H

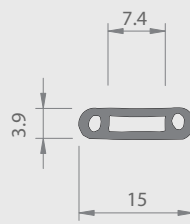

Nr. 15/97 W



Nr. 54/26 TPU

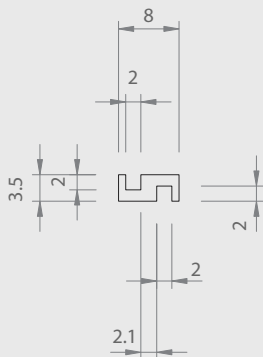

Nr. 05/21 ABS

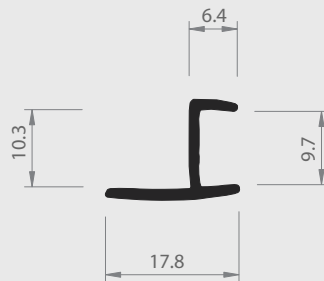

Nr. 40/43 H

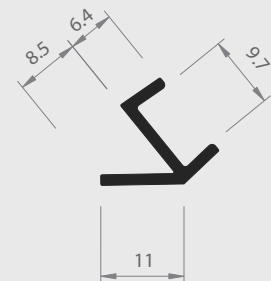

Nr. 40/44 H

= Hart PVC
 = Weich PVC | HH = Halbhart PVC
 = Andere Kunststoffe

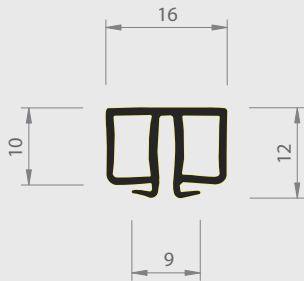

Nr. 19/65 H

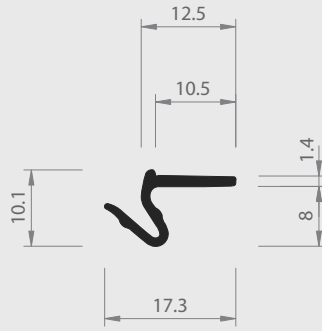

Nr. 21/49 H

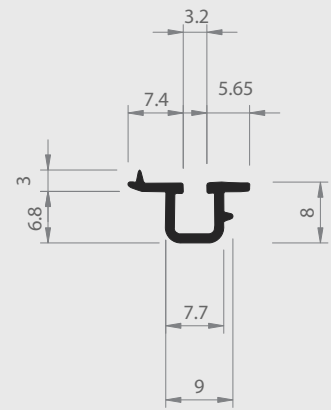

Nr. 05/19 H

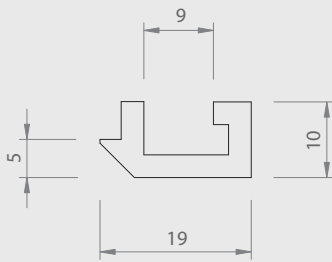

Nr. 07/10 PP

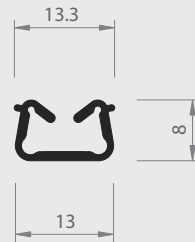

Nr. 04/32 H

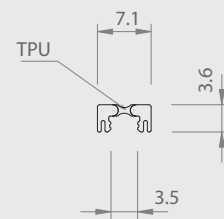

Nr. 24/23 ABS/TPU

■ = Hart PVC

■ = Weich PVC | HH = Halbhart PVC

□ = Andere Kunststoffe

20 | SONDERPROFILE

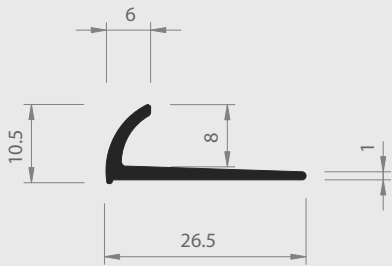

Nr. 26/05 H

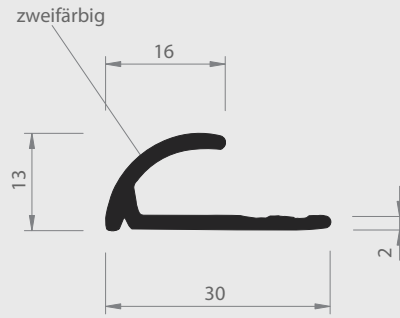

Nr. 04/29 H

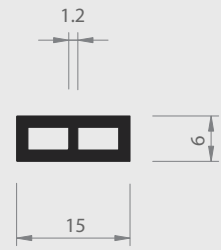

Nr. 22/28 H

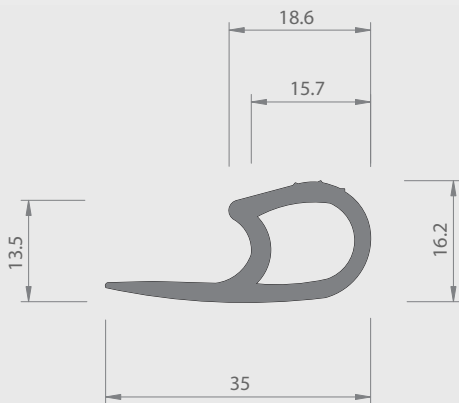

Nr. 32/21 HH



Nr. 04/05 ABS

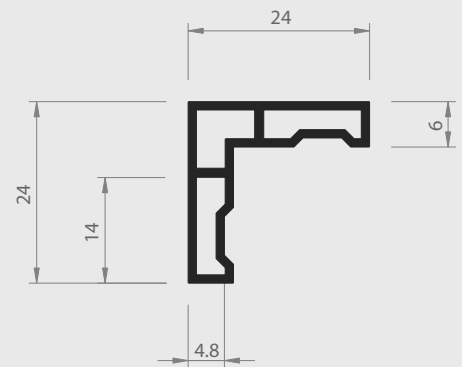

Nr. 22/27 H

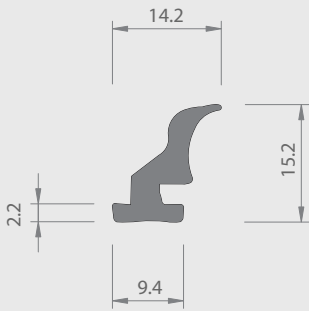

Nr. 24/20 HH

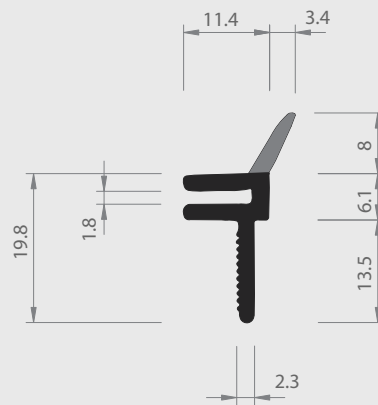

Nr. 28/20 H+W

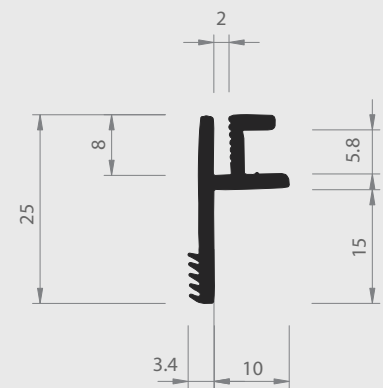

Nr. 28/21 H

= Hart PVC
 = Weich PVC | HH = Halbhart PVC
 = Andere Kunststoffe

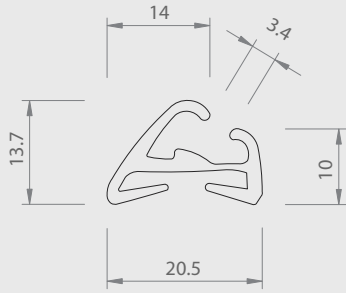

Nr. 16/52 ABS

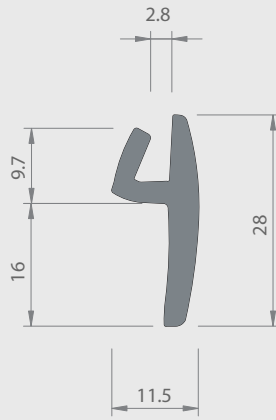

Nr. 19/48 W

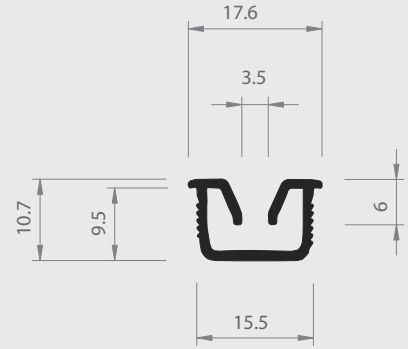

Nr. 09/51 H

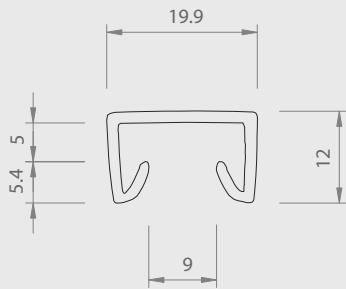

Nr. 04/03 ABS

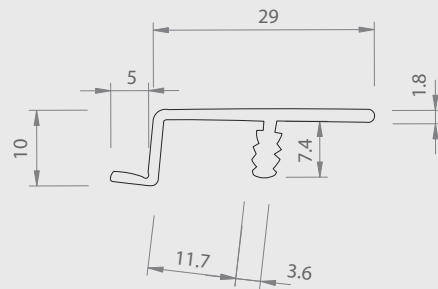

Nr. 09/46 PS

= Hart PVC
 = Weich PVC | HH = Halbhart PVC
 = Andere Kunststoffe

20 | SONDERPROFILE

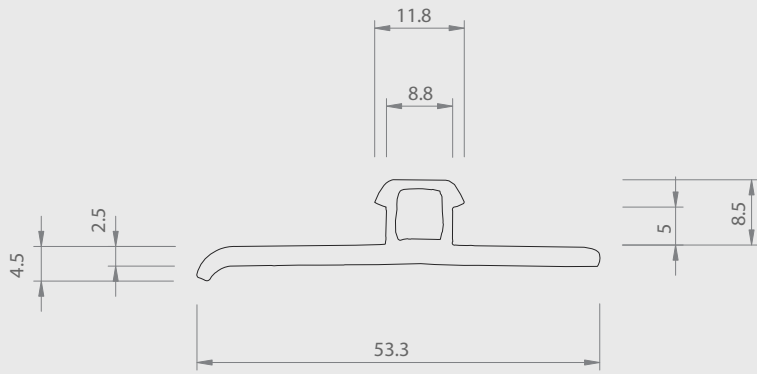

Nr. 04/04 ABS

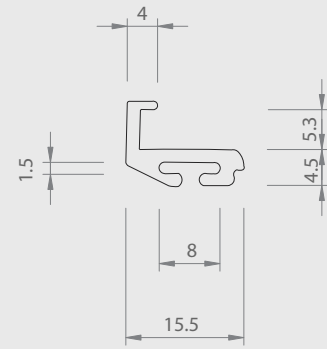

Nr. 26/25 PMMA

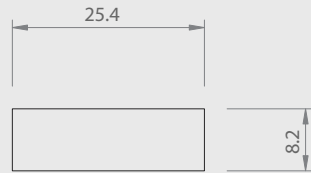

Nr. 29/42 ABS

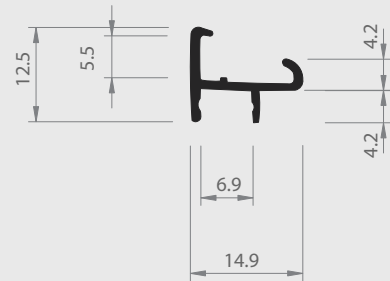

Nr. 01/79 H

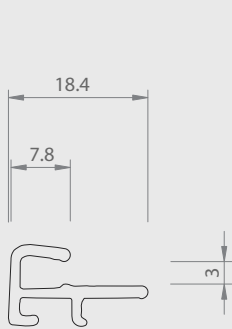

Nr. 27/08b ABS

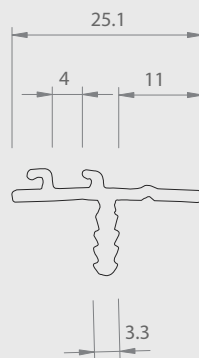

Nr. 27/08a ABS

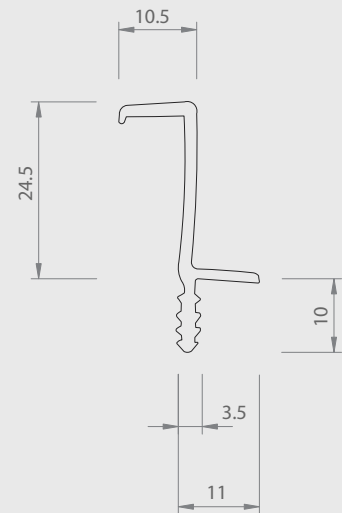

Nr. 27/07 ABS

■ = Hart PVC

■ = Weich PVC | HH = Halbhart PVC

□ = Andere Kunststoffe

20 | SONDERPROFILE

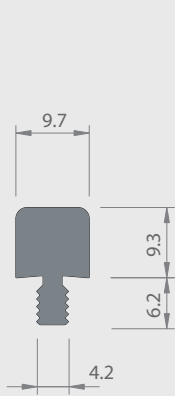

Nr. 21/30 HH

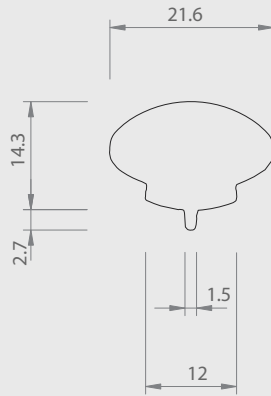

Nr. 04/01 ABS

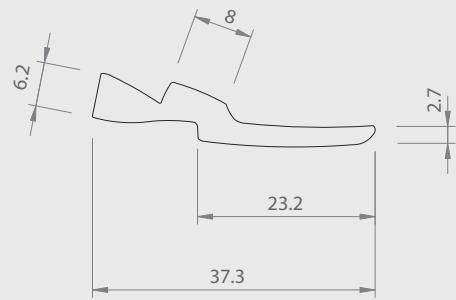

Nr. 01/73 TPU

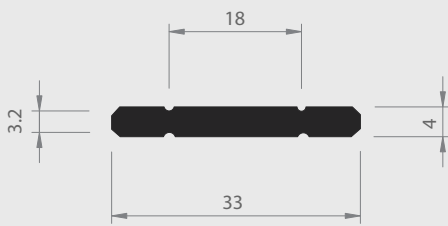

Nr. 29/03 H

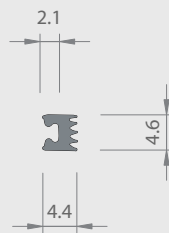

Nr. 29/04 W

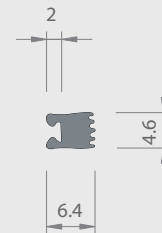

Nr. 29/06 W

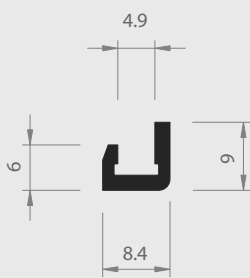

Nr. 04/23 H

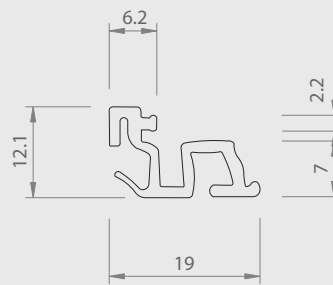

Nr. 29/01 ABS

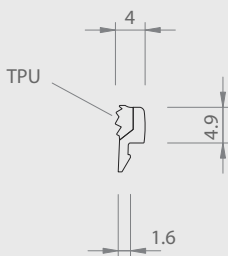

Nr. 29/02 ABS/TPU

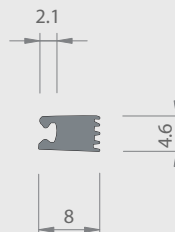

Nr. 29/08 W

= Hart PVC
 = Weich PVC | HH = Halbhart PVC
 = Andere Kunststoffe

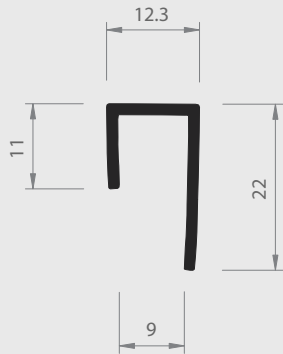

Nr. 37/35 H

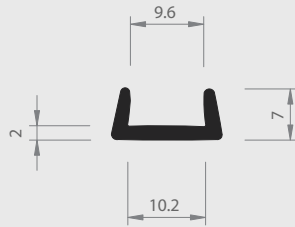

Nr. 40/37 H

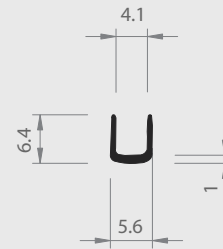

Nr. 40/39 H

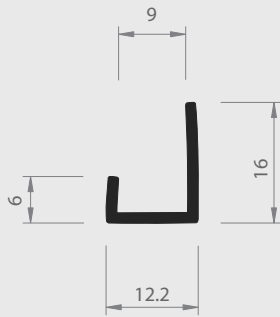

Nr. 37/34 H

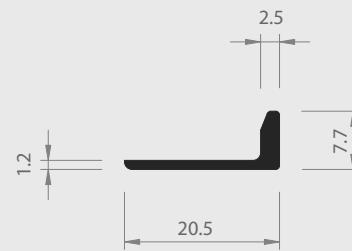

Nr. 27/25 H

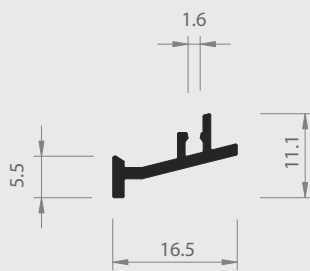

Nr. 21/31 H

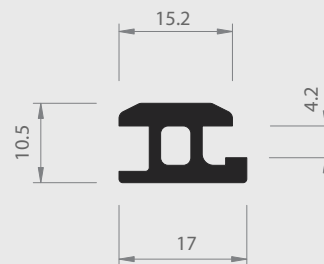

Nr. 09/62 H

= Hart PVC
 = Weich PVC | HH = Halbhart PVC
 = Andere Kunststoffe

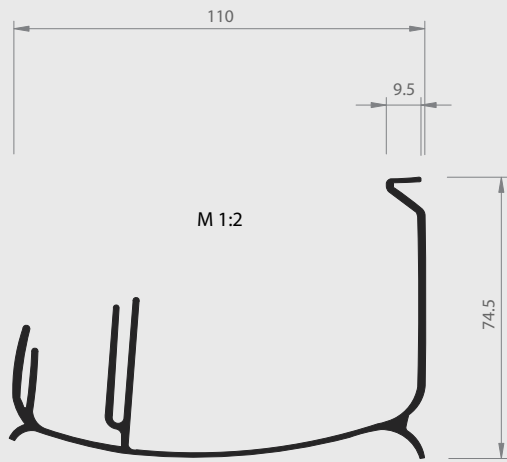

Nr. 38/01 H

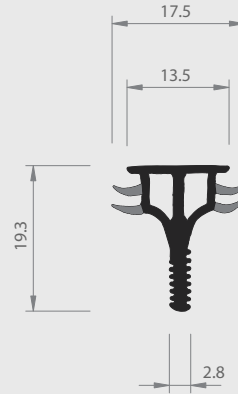

Nr. 25/52 H+W

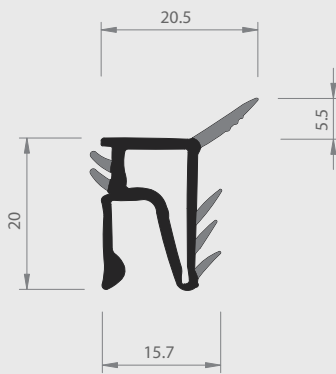

Nr. 28/02 H+W

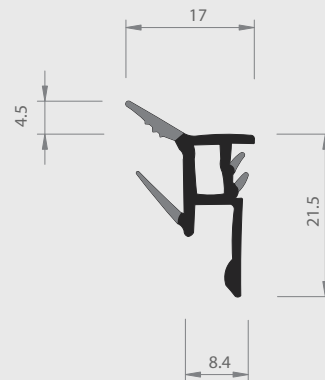

Nr. 28/03 H+W

= Hart PVC
 = Weich PVC | HH = Halbhart PVC
 = Andere Kunststoffe

20 | SONDERPROFILE

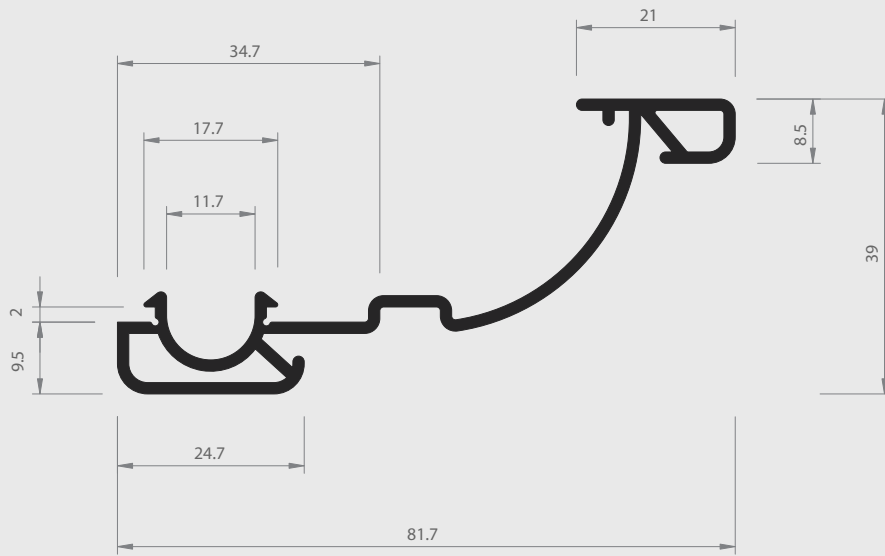

Nr. 09/95 H

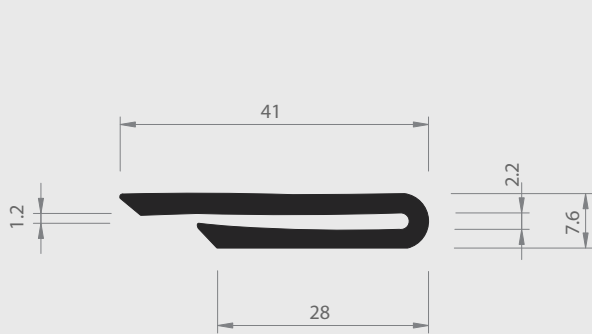

Nr. 25/21 H

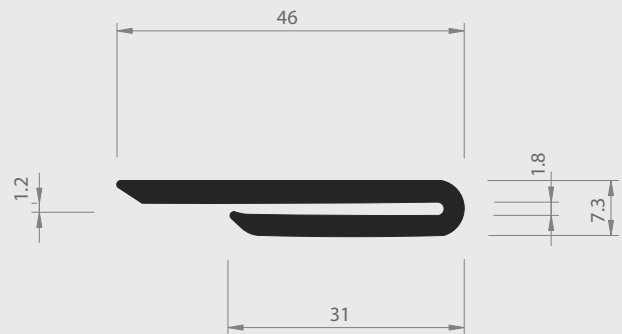

Nr. 25/22 H

= Hart PVC
 = Weich PVC | HH = Halbhart PVC
 = Andere Kunststoffe

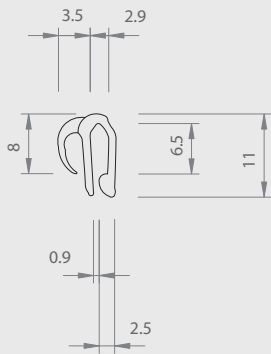

Nr. 20/28 PP+TPE

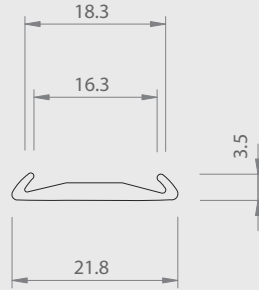

Nr. 05/29 PMMA

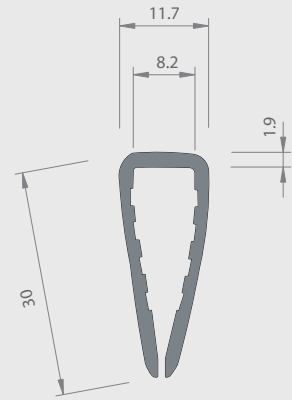

Nr. 25/32 HH

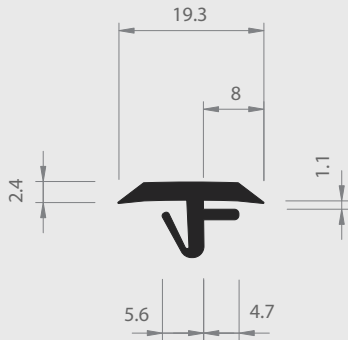

Nr. 19/44 H

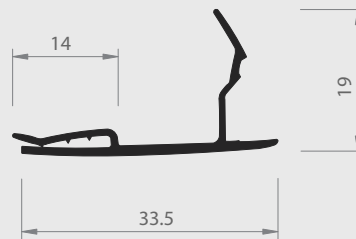

Nr. 19/50a H

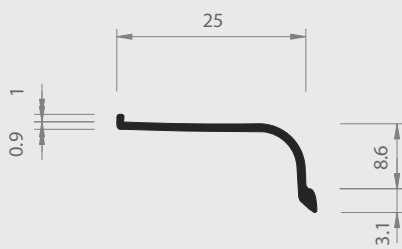

Nr. 19/52 H

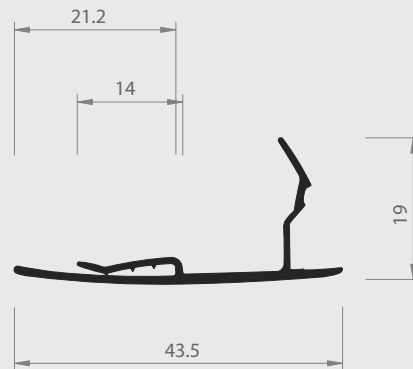

Nr. 19/50 H

= Hart PVC
 = Weich PVC | HH = Halbhart PVC
 = Andere Kunststoffe

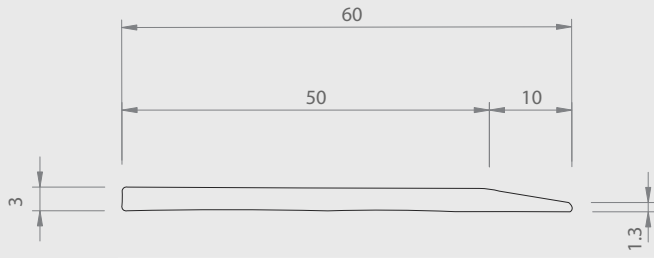

Nr. 19/49 ABS/PC

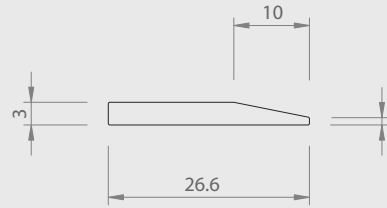

Nr. 19/49a PC

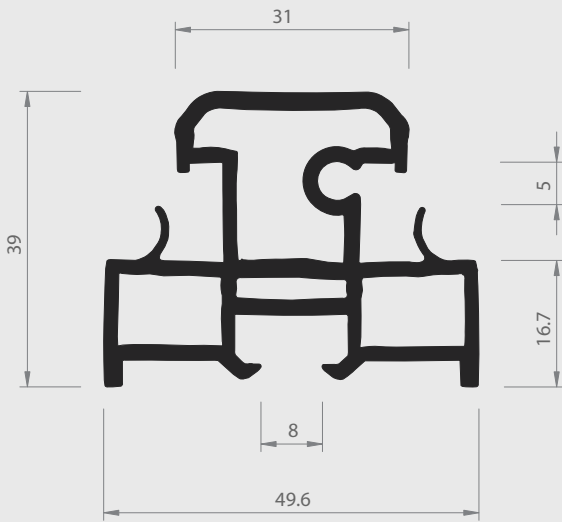

Nr. 09/82 H



Nr. 09/81 H

= Hart PVC
 = Weich PVC | HH = Halbhart PVC
 = Andere Kunststoffe

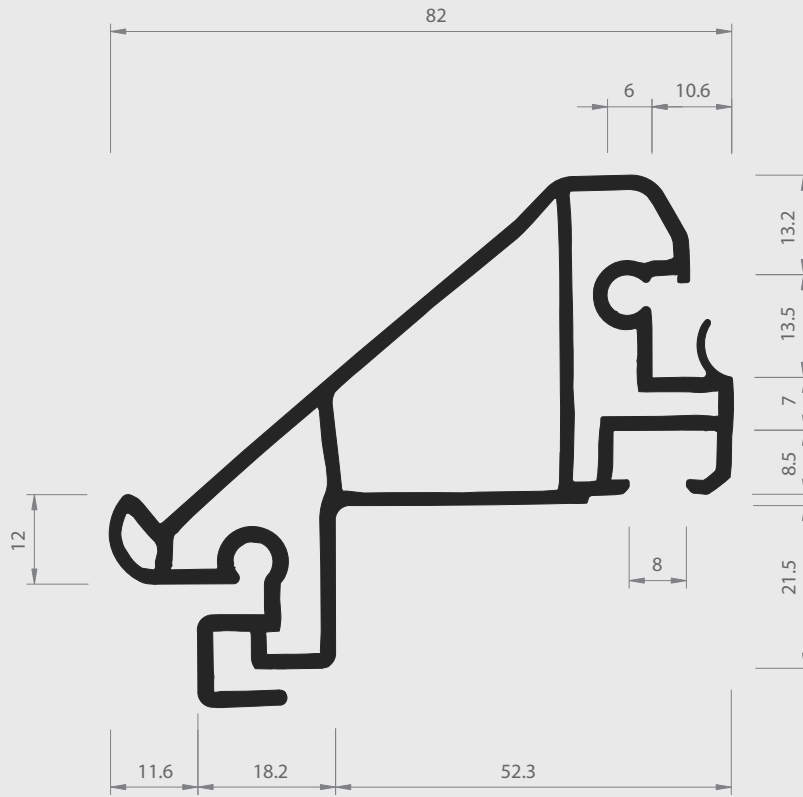

Nr. 09/80 H

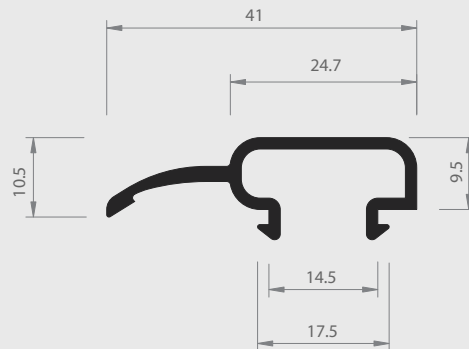

Nr. 09/94 H

= Hart PVC
 = Weich PVC | HH = Halbhart PVC
 = Andere Kunststoffe

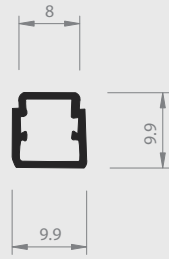

Nr. 62/68 H

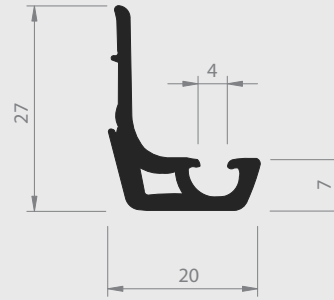

Nr. 23/94 H

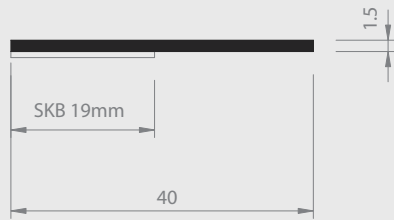

Nr. 31/11 H

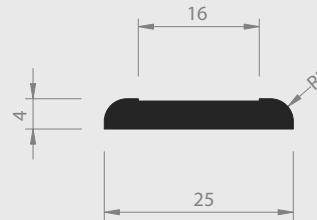

Nr. 26/43b H

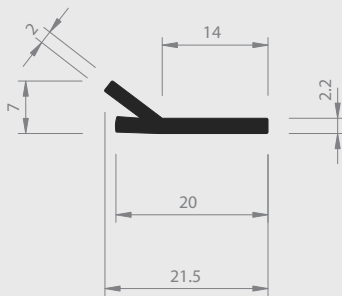

Nr. 29/87 H

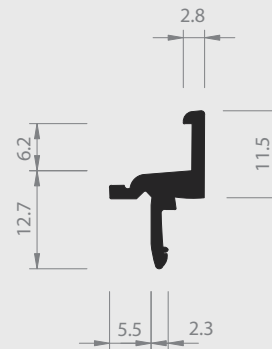

Nr. 15/50 H

= Hart PVC
 = Weich PVC | HH = Halhart PVC
 = Andere Kunststoffe

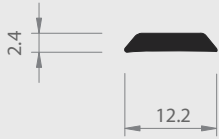

Nr. 25/48 H

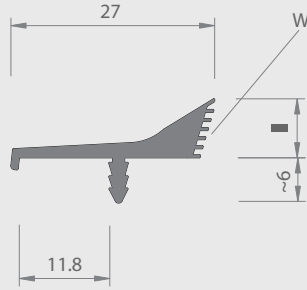

Nr. 60/37 HH+W

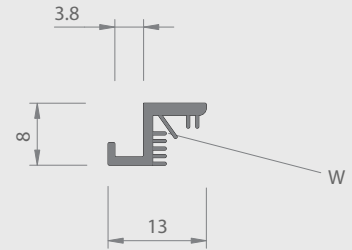

Nr. 60/38 HH+W

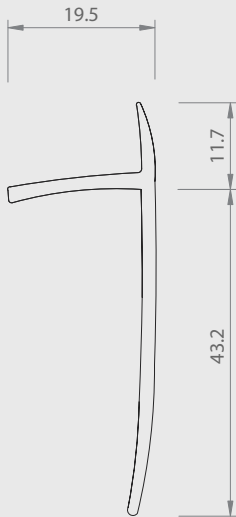

Nr. 14/57 PP

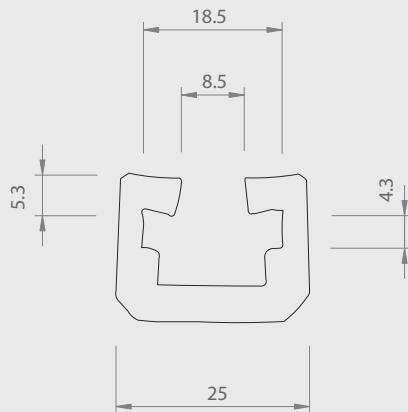

Nr. 22/30 HDPE

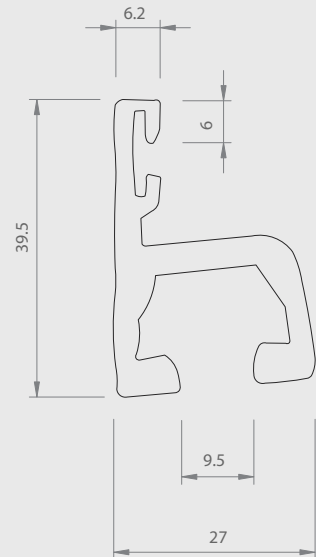

Nr. 22/38 HDPE

■ = Hart PVC

■ = Weich PVC | HH = Halbhart PVC

□ = Andere Kunststoffe

20 | SONDERPROFILE

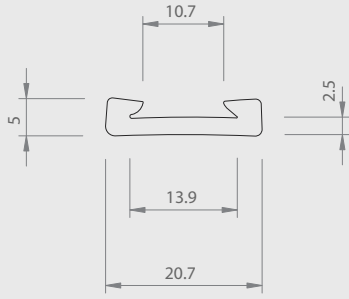

Nr. 25/47 PMMA

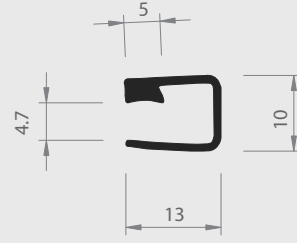

Nr. 36/35 H

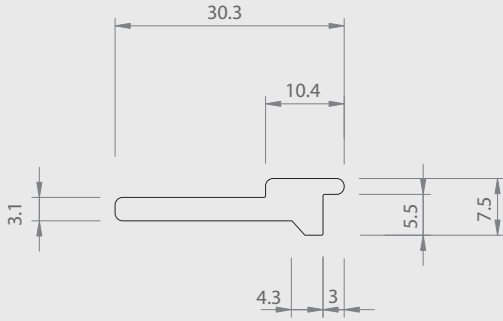

Nr. 01/72 ABS

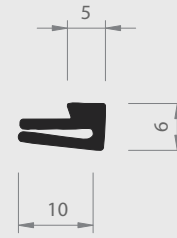

Nr. 36/34 H

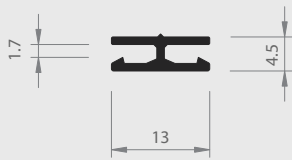

Nr. 28/72 H

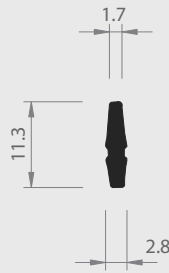

Nr. 28/73 H

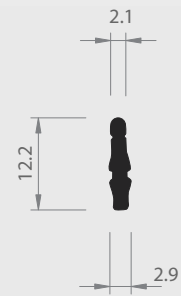

Nr. 28/73a H

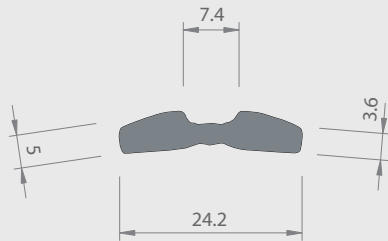

Nr. 08/47 W

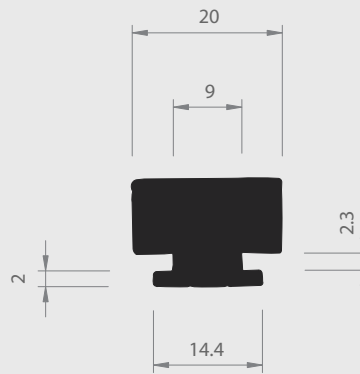

Nr. 25/01-2 H

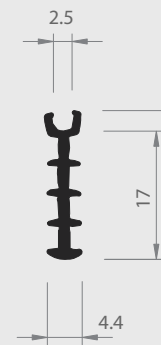

Nr. 19/57 H

= Hart PVC
 = Weich PVC | HH = Halbhart PVC
 = Andere Kunststoffe

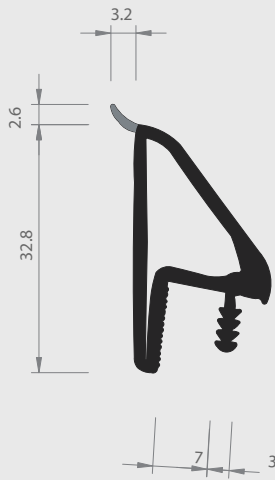

Nr. 28/05 H+W

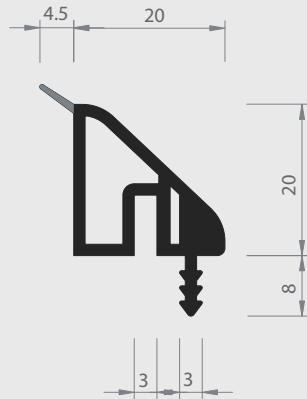

Nr. 28/07 H+W

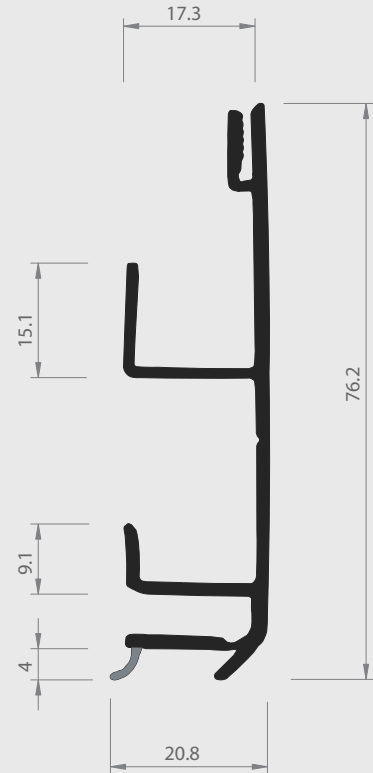

Nr. 14/99 H+W

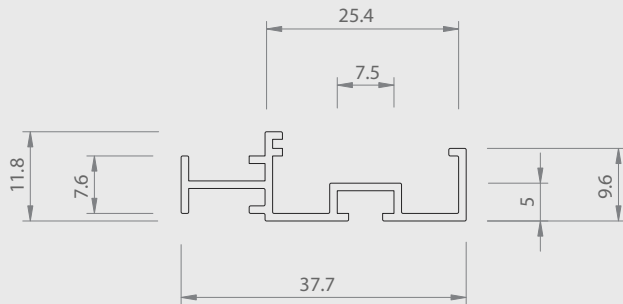

Nr. 09/12 PC

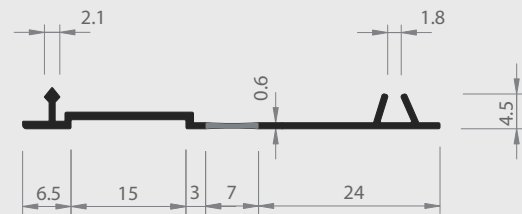

Nr. 9/87 H+W

= Hart PVC
 = Weich PVC | HH = Halbhart PVC
 = Andere Kunststoffe

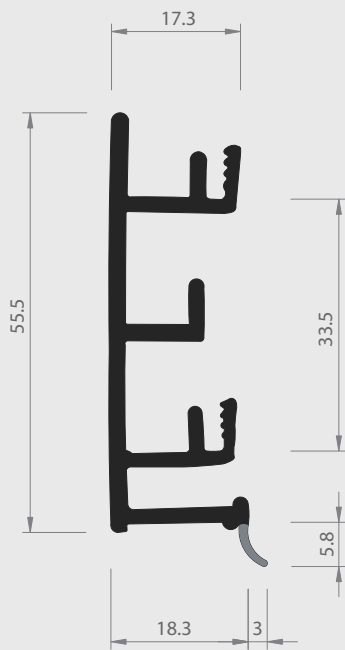

Nr. 14/98 H+W

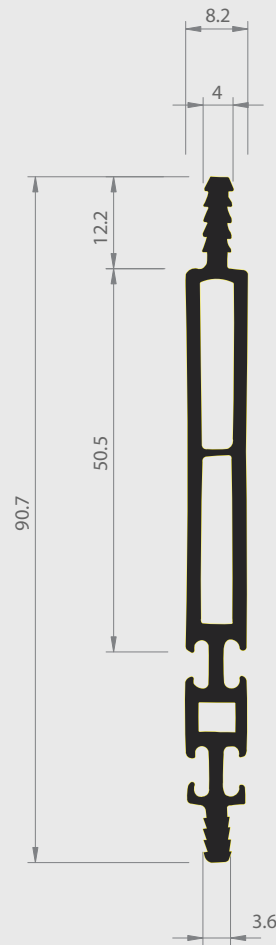

Nr. 25/49 H

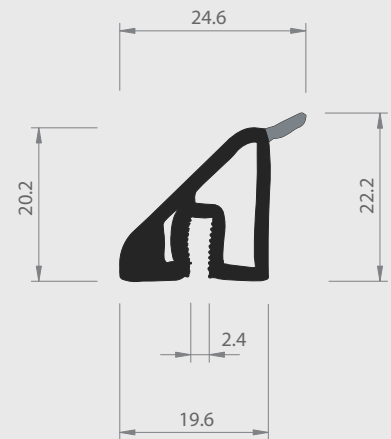

Nr. 28/06 H+W

= Hart PVC
 = Weich PVC | HH = Halbhart PVC
 = Andere Kunststoffe

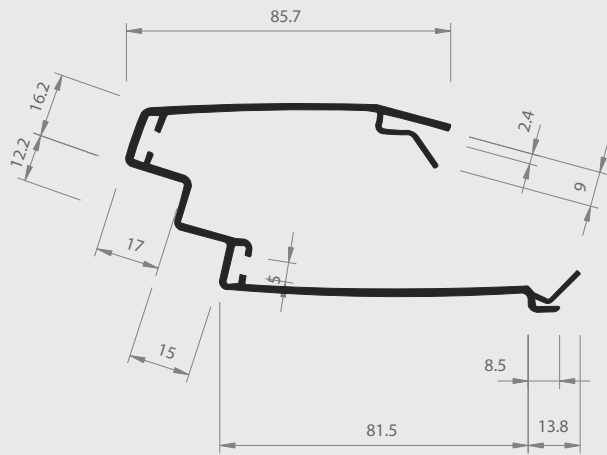

M 1:2

Nr. 22/79 H

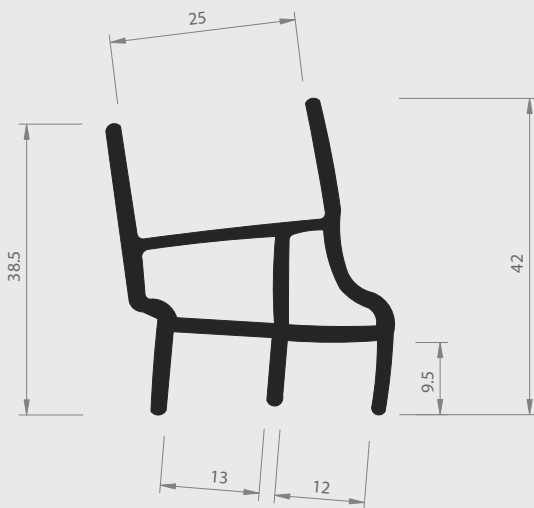

Nr. 22/76 H

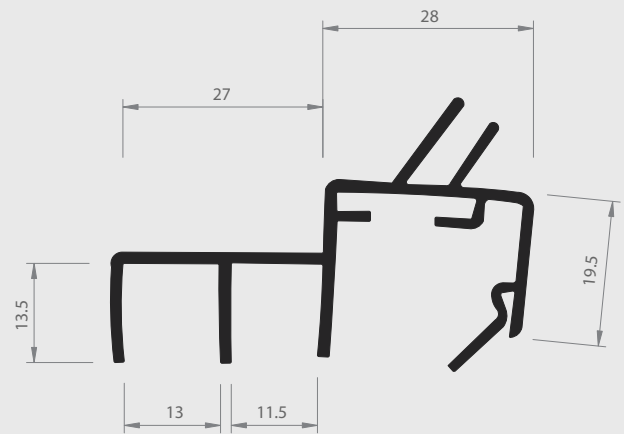

Nr. 22/75 H

= Hart PVC
 = Weich PVC | HH = Halbhart PVC
 = Andere Kunststoffe

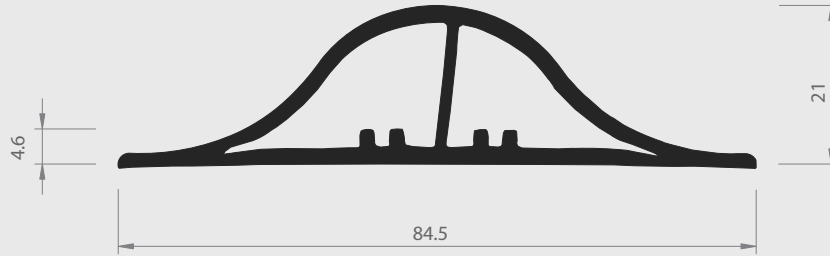

Nr. 22/74 H

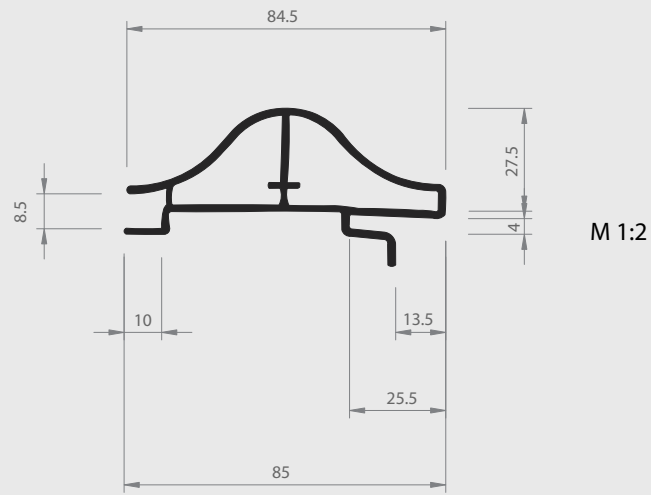

Nr. 22/77 H

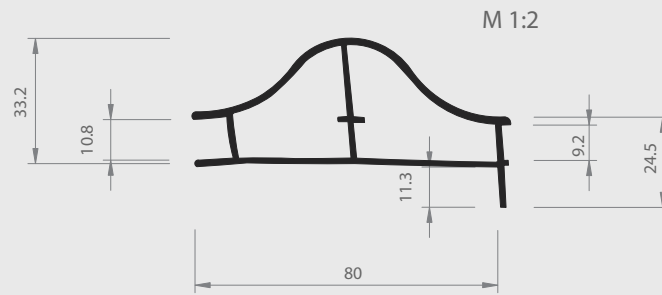

Nr. 22/78 H

= Hart PVC
 = Weich PVC | HH = Halbhart PVC
 = Andere Kunststoffe

20 | SONDERPROFILE

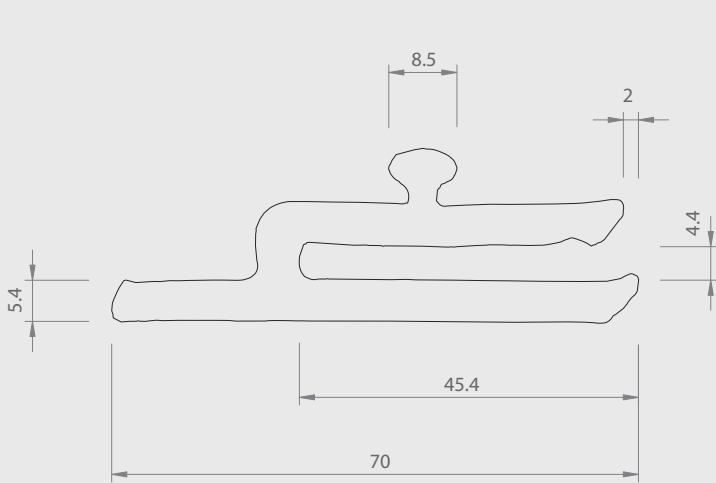

Nr. 02/29 HDPE

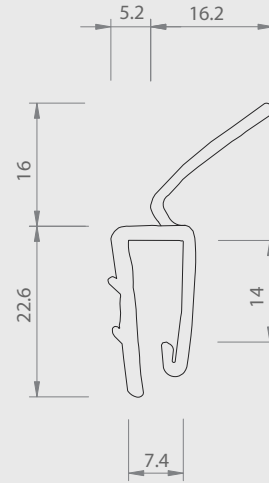

Nr. 29/21 HDPE+TPE

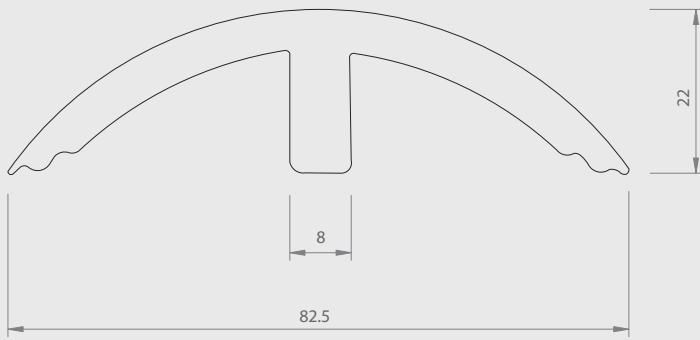

Nr. 62/83 PC

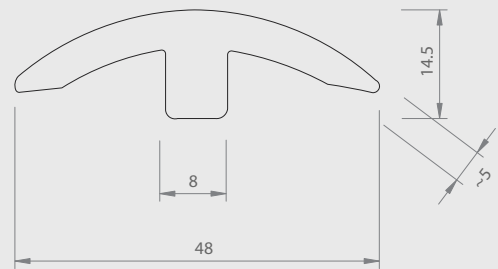

Nr. 62/81 PC

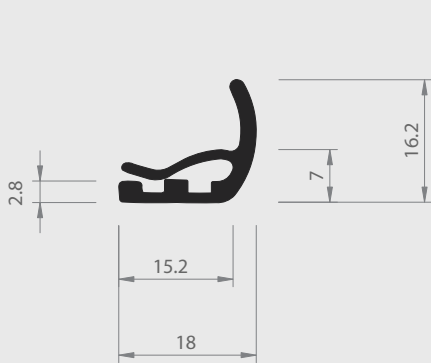

Nr. 23/66 H

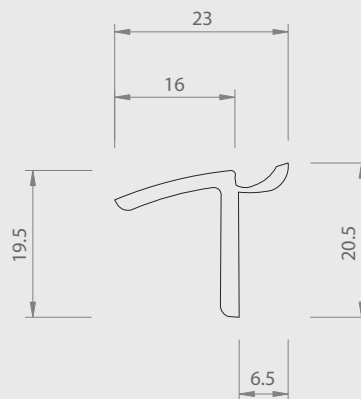

Nr. 51/02 ABS

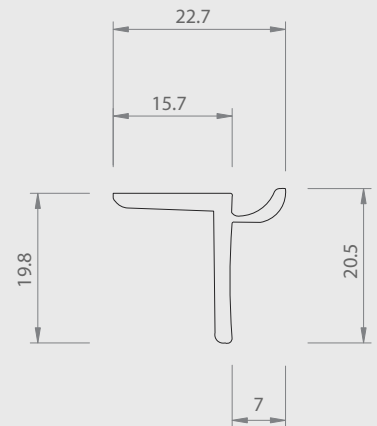

Nr. 51/01 ABS

■ = Hart PVC ■ = Weich PVC | HH = Halbhart PVC □ = Andere Kunststoffe

20 | SONDERPROFILE

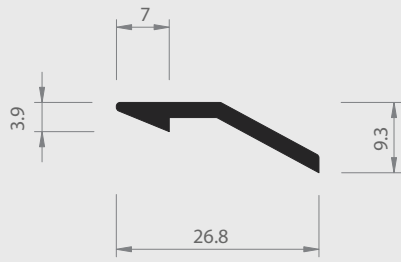

Nr. 27/28 H

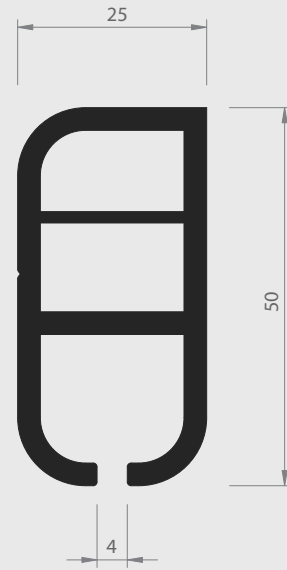

Nr. 17/47 H

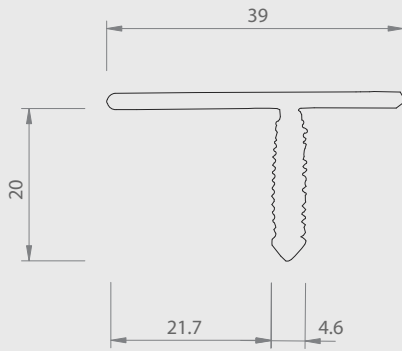

Nr. 25/57 PS

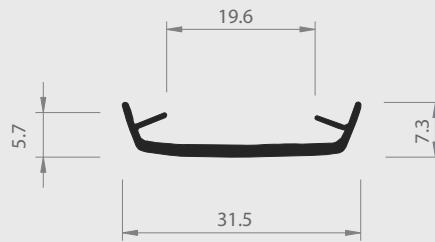

Nr. 17/68 H

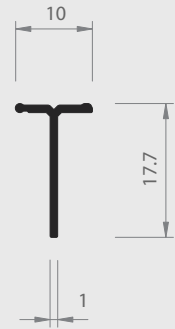

Nr. 25/56 H

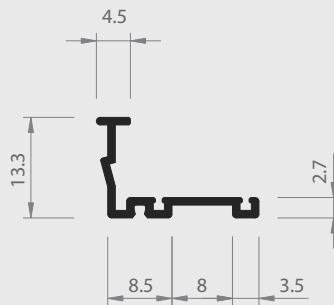

Nr. 16/94 H

= Hart PVC
 = Weich PVC | HH = Halbhart PVC
 = Andere Kunststoffe

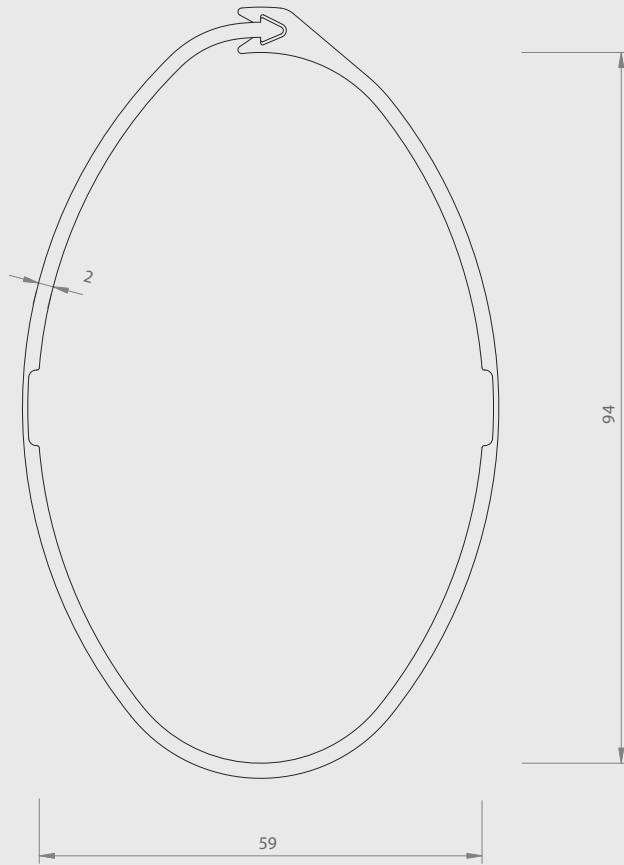

Nr. 56/24 HDPE

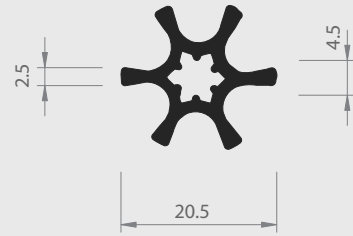

Nr. 05/18 H

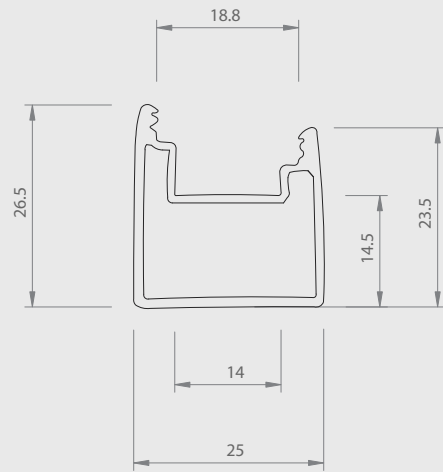

Nr. 33/01 ABS

= Hart PVC
 = Weich PVC | HH = Halbhart PVC
 = Andere Kunststoffe

M 1:2

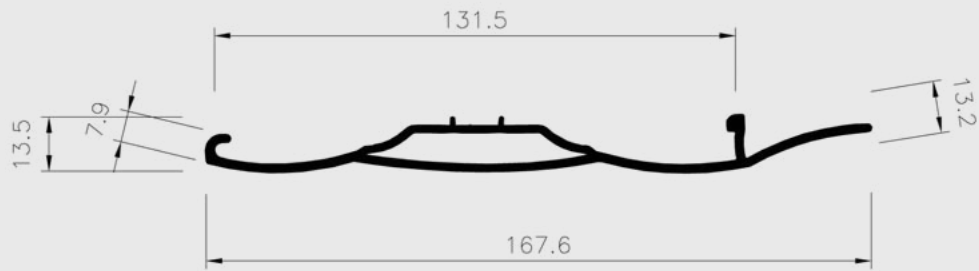

Nr. 09/83 H

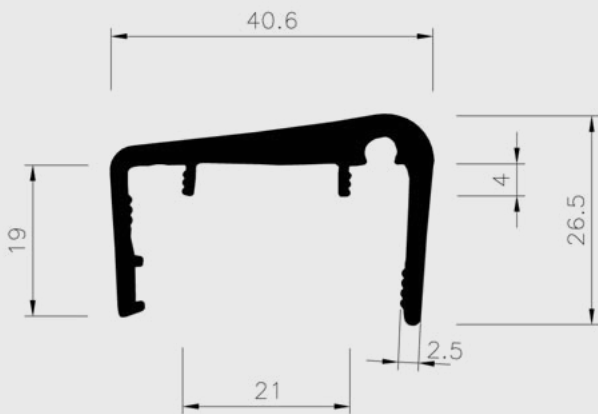

Nr. 09/77 H

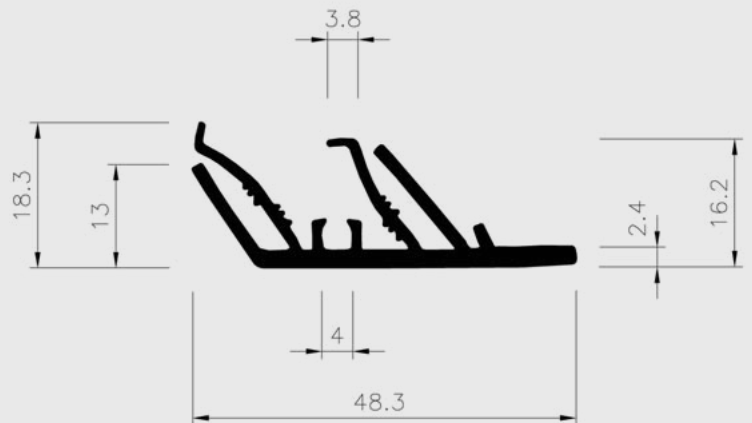

Nr. 09/84 H

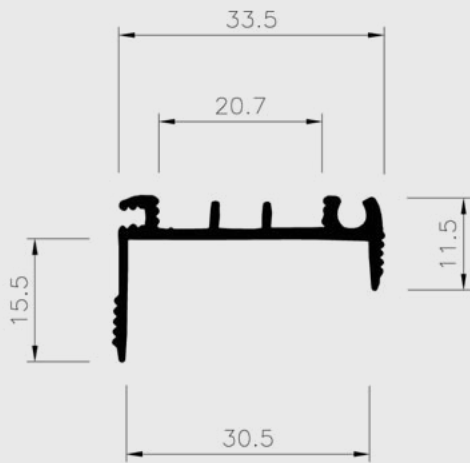

Nr. 09/76 H

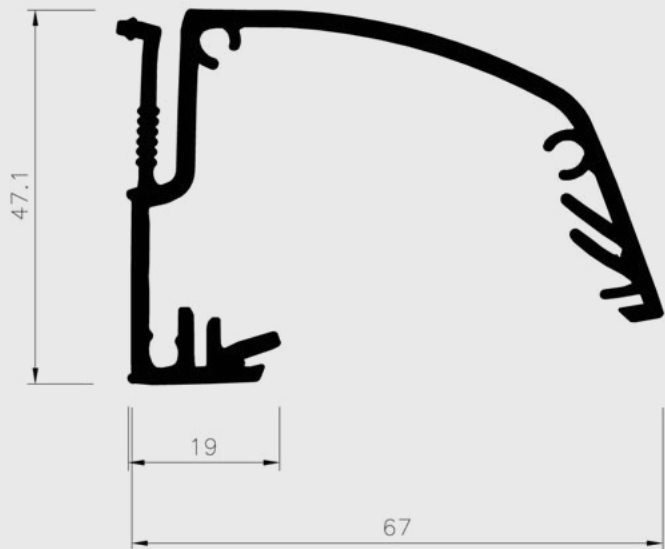

Nr. 09/78 H

= Hart PVC
 = Weich PVC | HH = Halbhart PVC
 = Andere Kunststoffe

20 | SONDERPROFILE

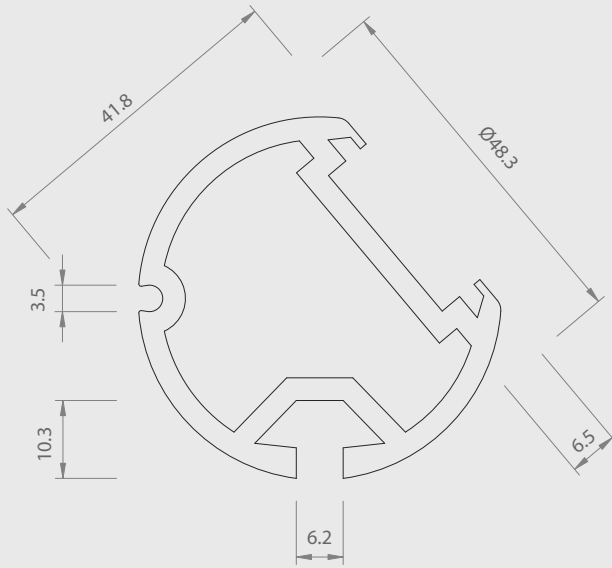

Nr. 52/01 PPE

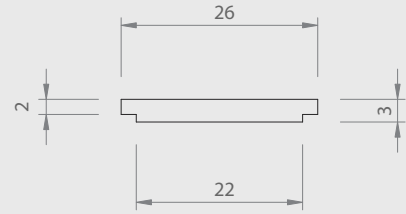

Nr. 26/29 PC

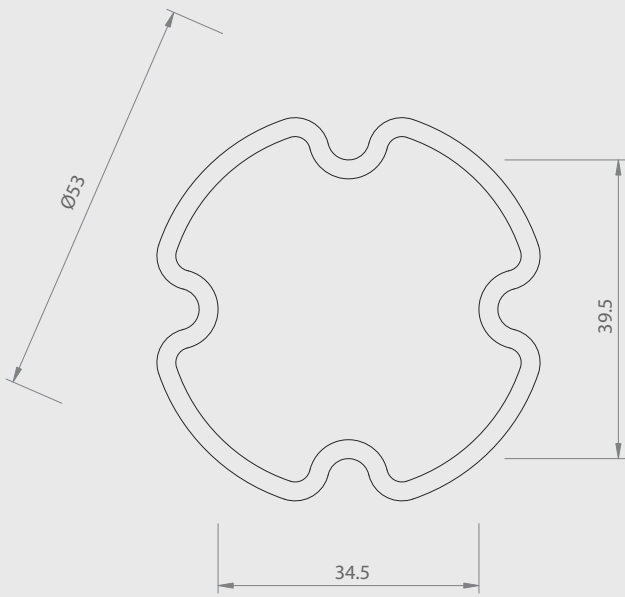

Nr. 50/38 ABS

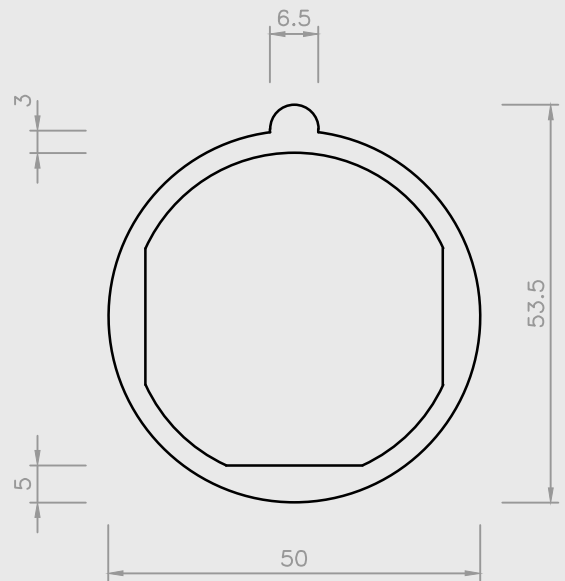

Nr. 54/07B HDPE

= Hart PVC
 = Weich PVC | HH = Halbhart PVC
 = Andere Kunststoffe

20 | SONDERPROFILE

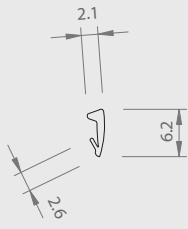

Nr. 01/75 HDPE

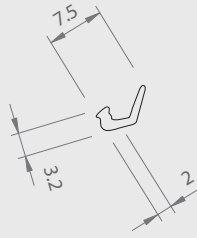

Nr. 01/76 TPU

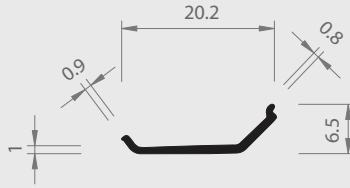

Nr. 1/77 H

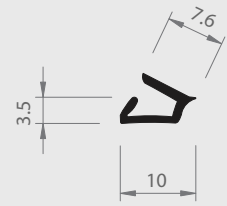

Nr. 09/86 H

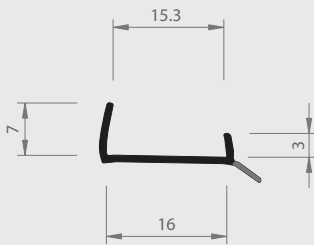

Nr. 19/51 H+W

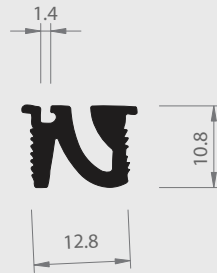

Nr. 09/50 H

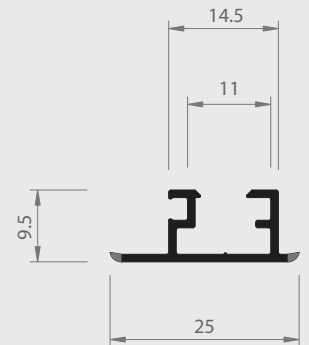

Nr. 24/98 H+W

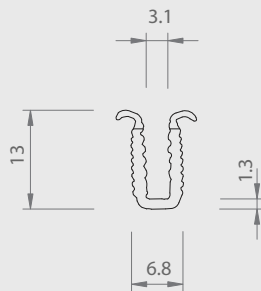

Nr. 24/45 ABS+TPE

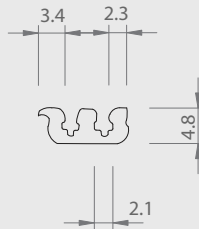

Nr. 22/65 PP

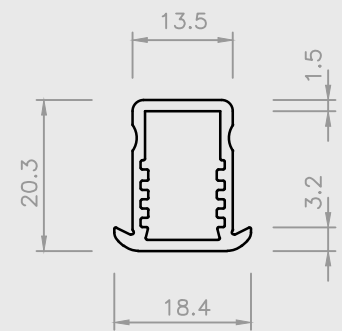

Nr. 33/02 PC

= Hart PVC
 = Weich PVC | HH = Halbhart PVC
 = Andere Kunststoffe

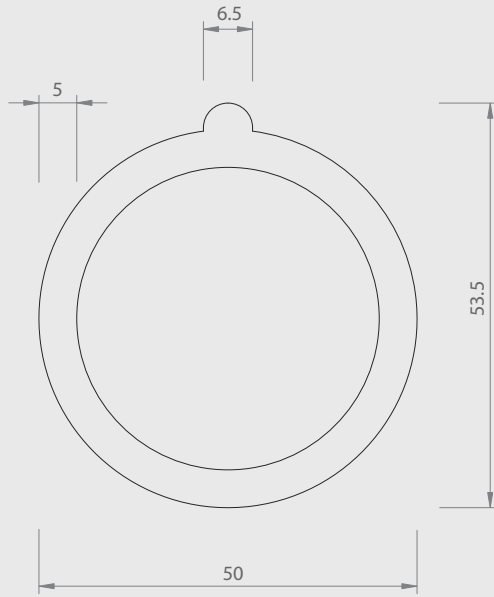

Nr. 54/07 HDPE

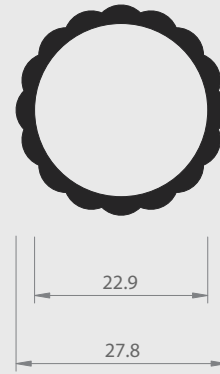

Nr. 54/05 H

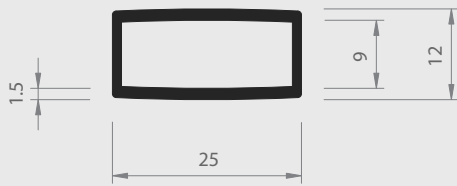

Nr. 54/49 H

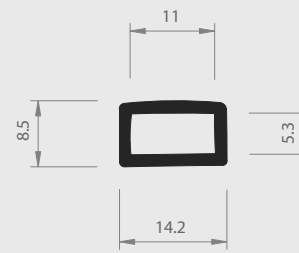

Nr. 54/47 H

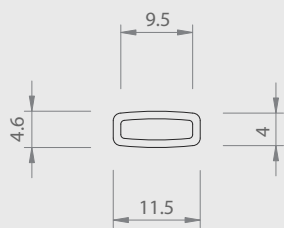

Nr. 54/12 TPU

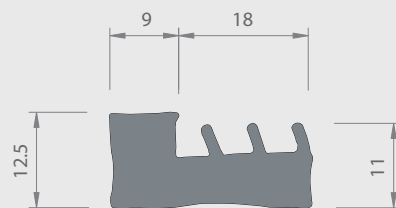

Nr. 25/26 HH

= Hart PVC
 = Weich PVC | HH = Halhart PVC
 = Andere Kunststoffe

20 | SONDERPROFILE

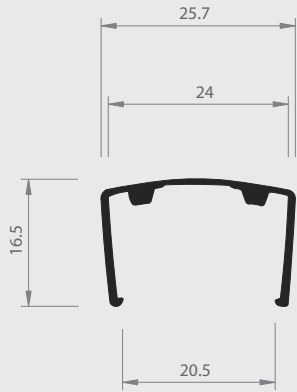

Nr. 04/21 H

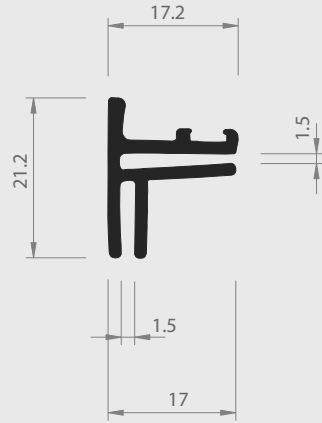

Nr. 16/71 H

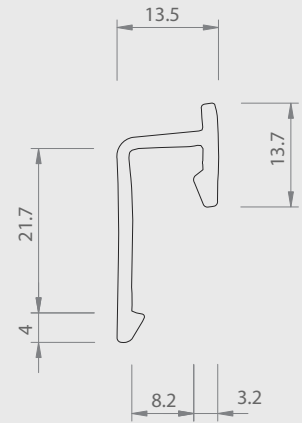

Nr. 20/87 ABS

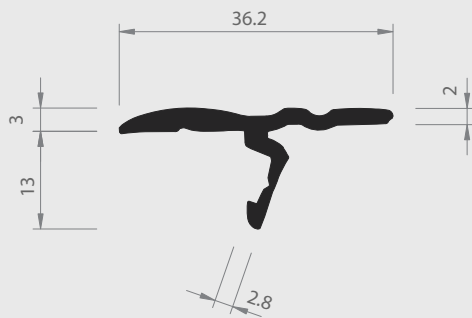

Nr. 16/77 H

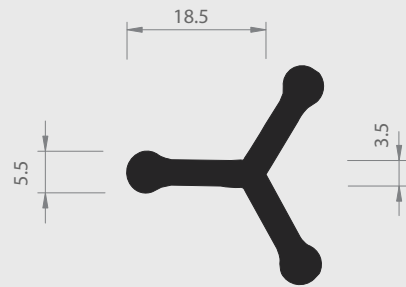

Nr. 60/62 H

= Hart PVC
 = Weich PVC | HH = Halbhart PVC
 = Andere Kunststoffe

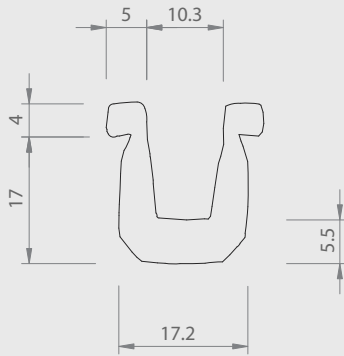

Nr. 51/19 PE

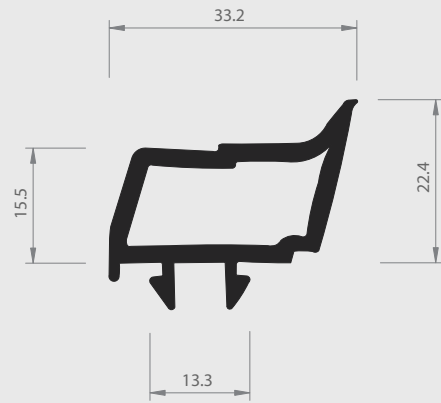

Nr. 29/20 H

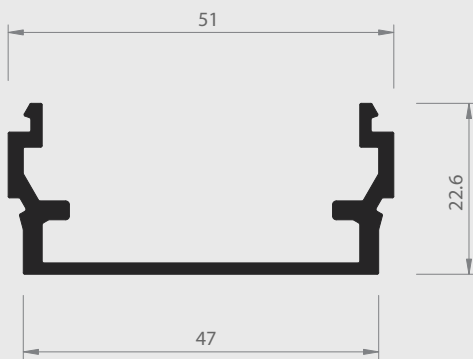

Nr. 28/18a H

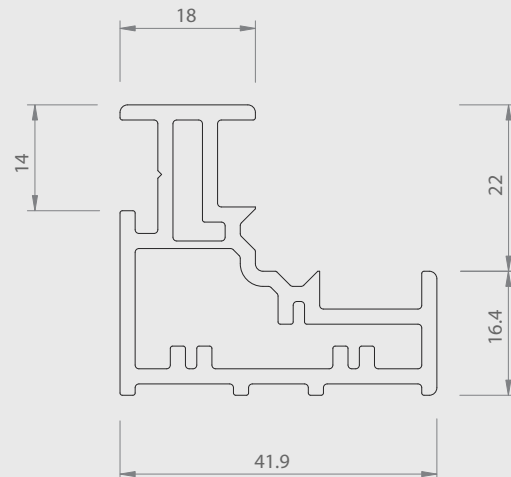

Nr. 23/03 ABS

= Hart PVC
 = Weich PVC | HH = Halbhart PVC
 = Andere Kunststoffe

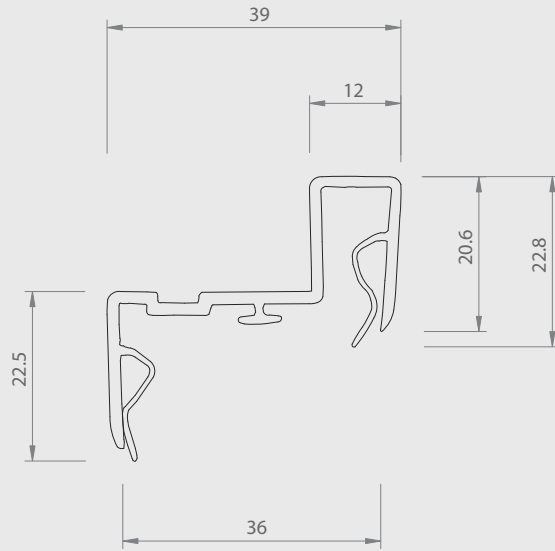

Nr. 22/82 ABS

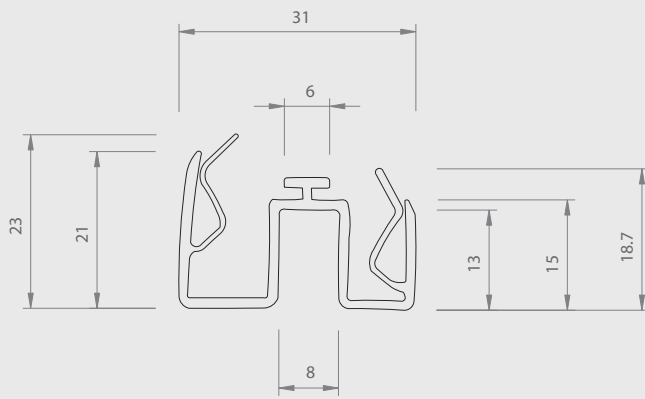

Nr. 22/81 ABS

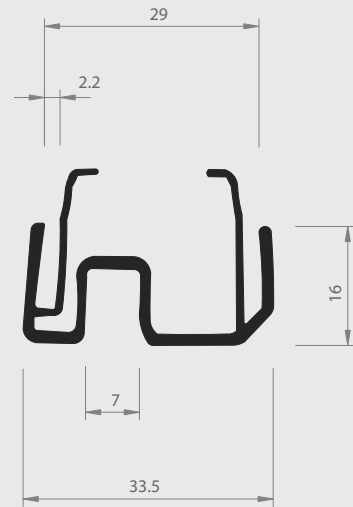

Nr. 23/75 H

= Hart PVC
 = Weich PVC | HH = Halbhart PVC
 = Andere Kunststoffe

20 | SONDERPROFILE

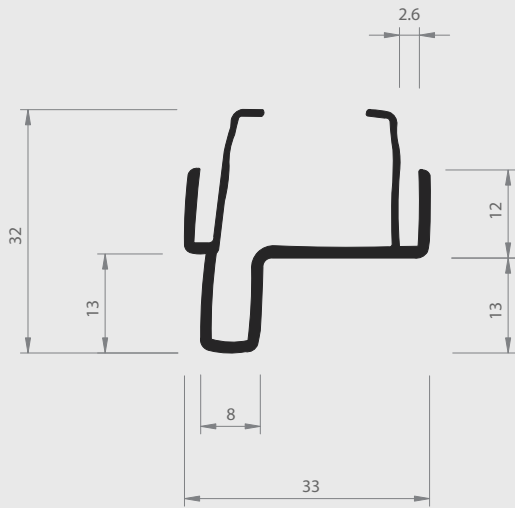

Nr. 23/76 H

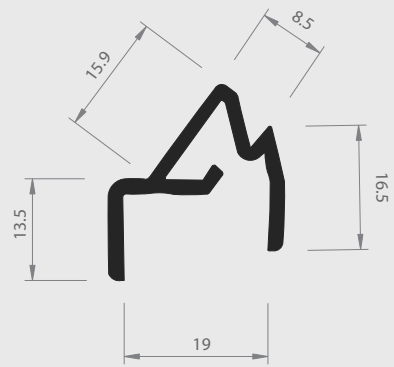

Nr. 29/66 H

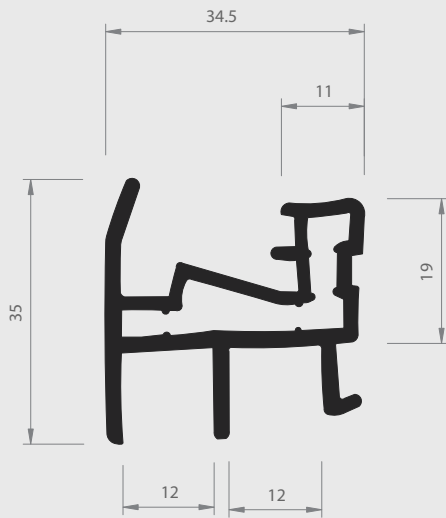

Nr. 29/65 H

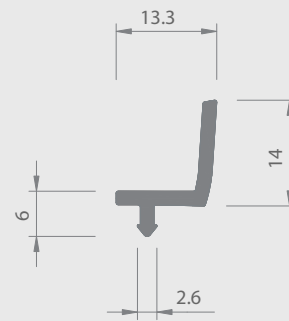

Nr. 17/52 W

■ = Hart PVC ■ = Weich PVC | HH = Halhart PVC □ = Andere Kunststoffe

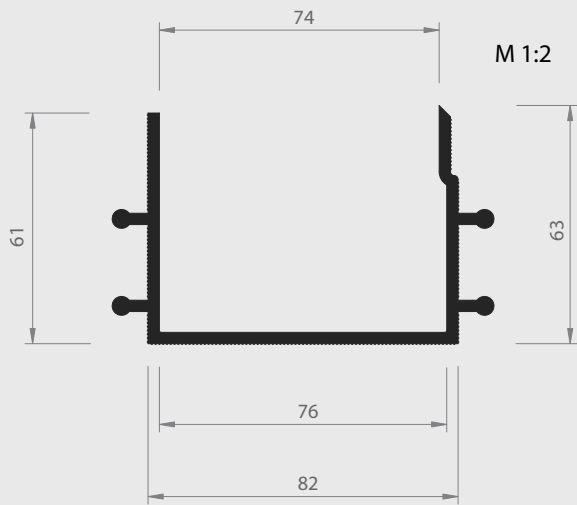

Nr. 30/27 H

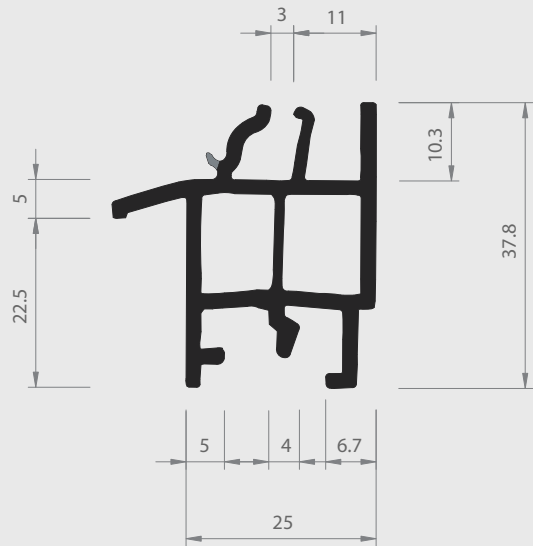

Nr. 27/05 H+W

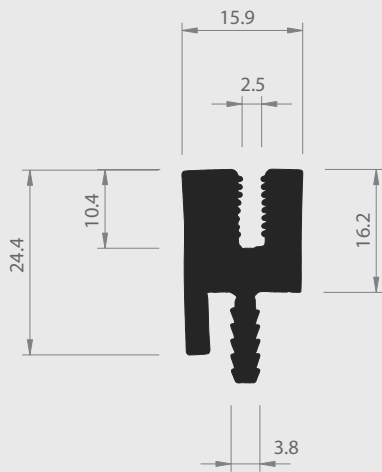

Nr. 25/51 H

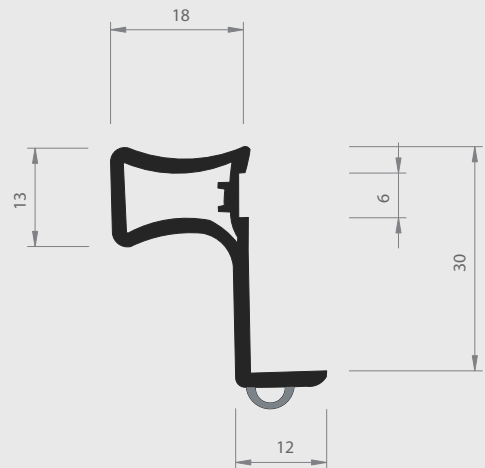

Nr. 20/56 H+W

= Hart PVC
 = Weich PVC | HH = Halbhart PVC
 = Andere Kunststoffe

20 | SONDERPROFILE

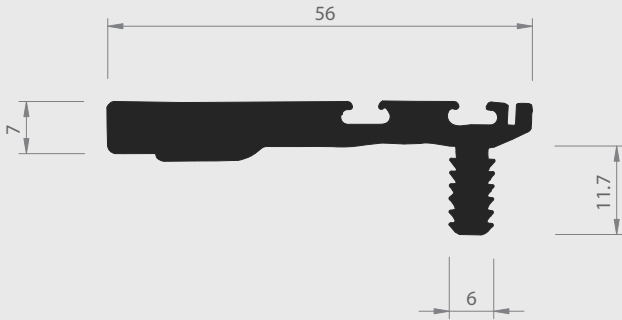

Nr. 25/50 H

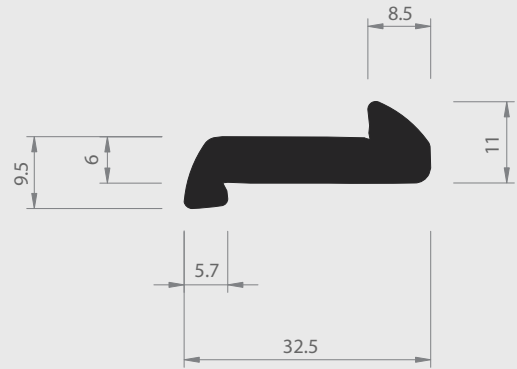

Nr. 26/71 H

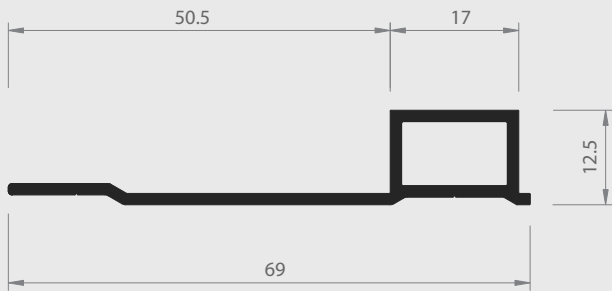

Nr. 27/39 H

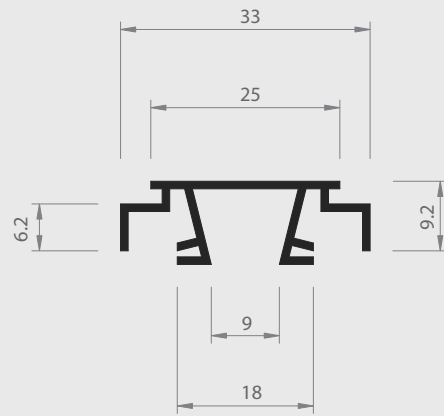

Nr. 24/97 H

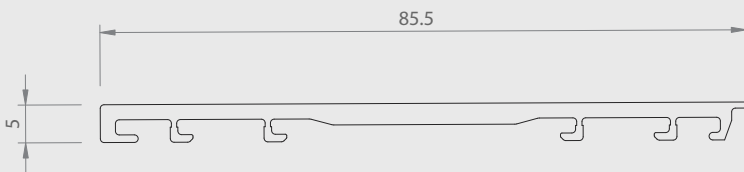

Nr. 31/10 ASA

= Hart PVC
 = Weich PVC | HH = Halbhart PVC
 = Andere Kunststoffe

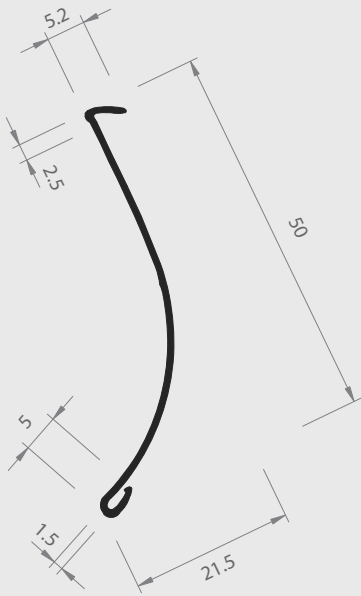

Nr. 09/98 H

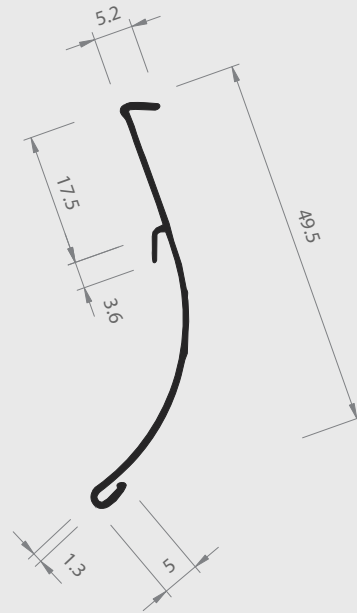

Nr. 09/97 H



Nr. 09/96 H

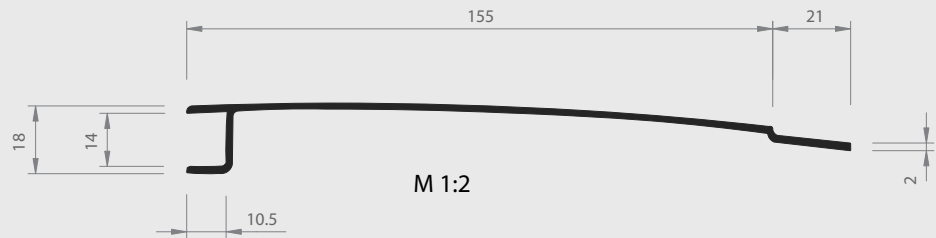

M 1:2

Nr. 22/80 H

= Hart PVC
 = Weich PVC | HH = Halbhart PVC
 = Andere Kunststoffe

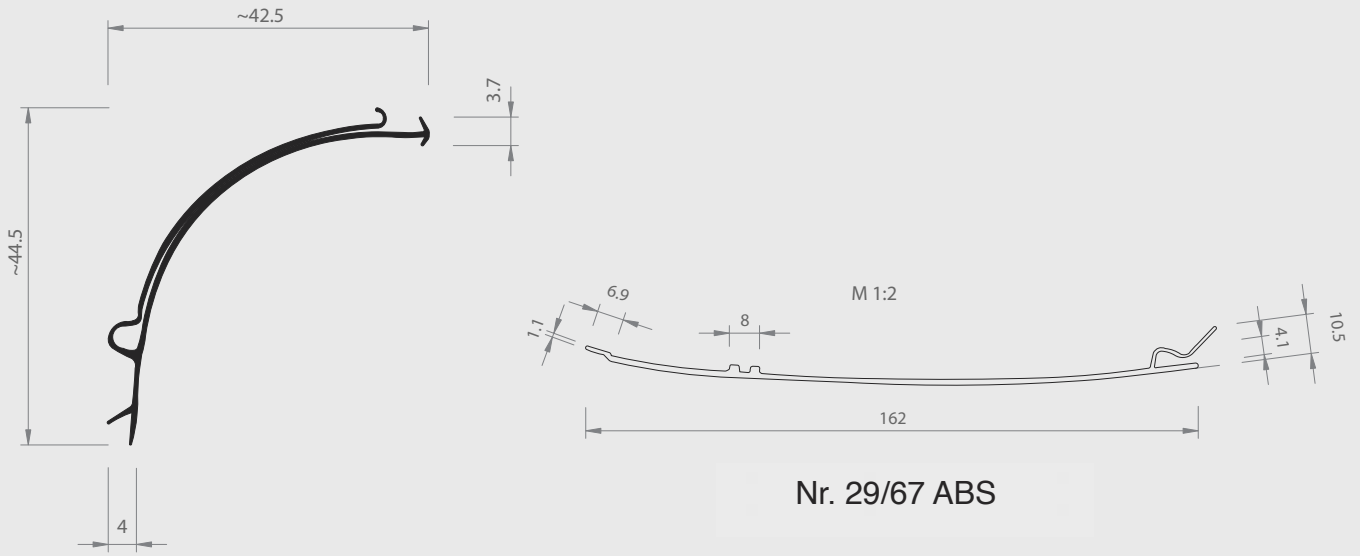

Nr. 09/90B H

Nr. 29/67 ABS

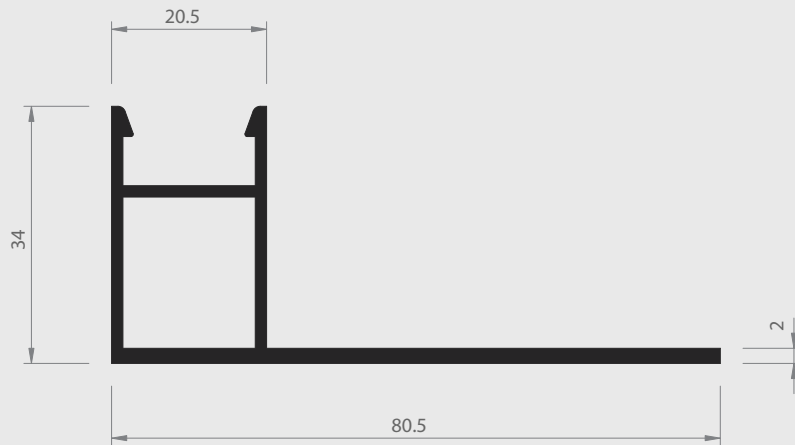

Nr. 16/65 H

= Hart PVC
 = Weich PVC | HH = Halbhart PVC
 = Andere Kunststoffe

20 | SONDERPROFILE

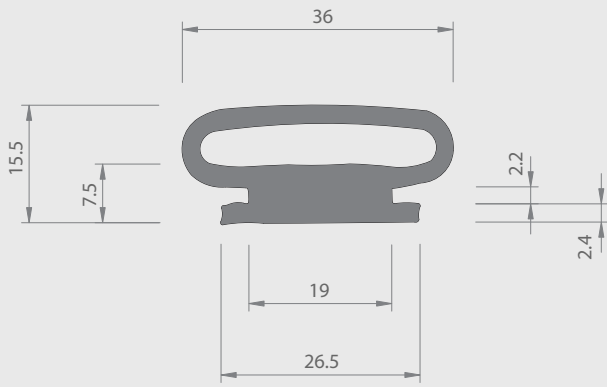

Nr. 54/08 W

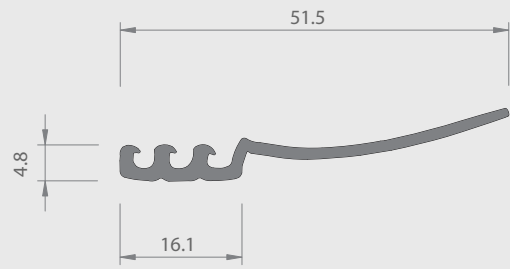

Nr. 41/04 W

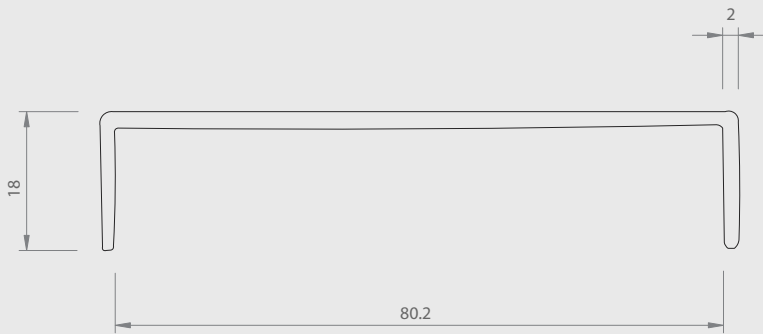

Nr. 50/37 ABS

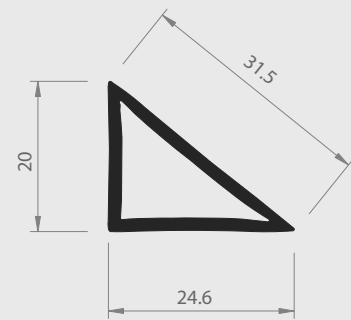

Nr. 61/68 H

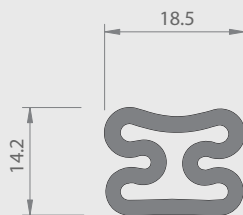

Nr. 54/25 W



Nr. 08/02 H

= Hart PVC
 = Weich PVC | HH = Halbhart PVC
 = Andere Kunststoffe

20 | SONDERPROFILE

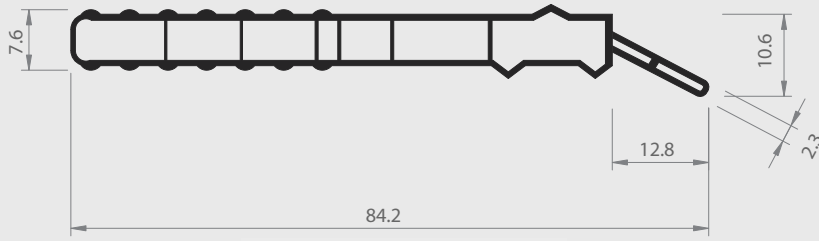

Nr. 09/13 H

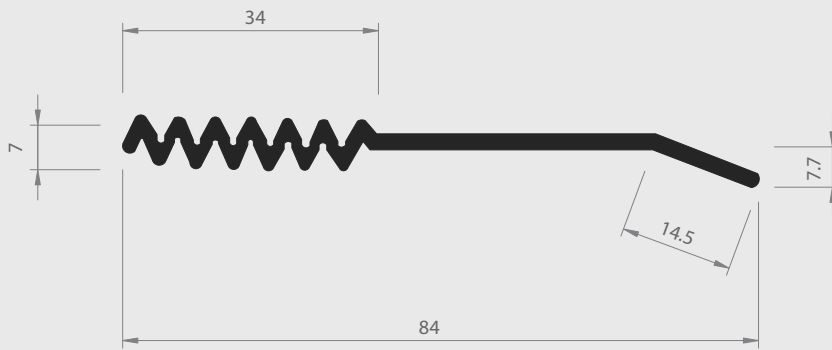

Nr. 9/19 H

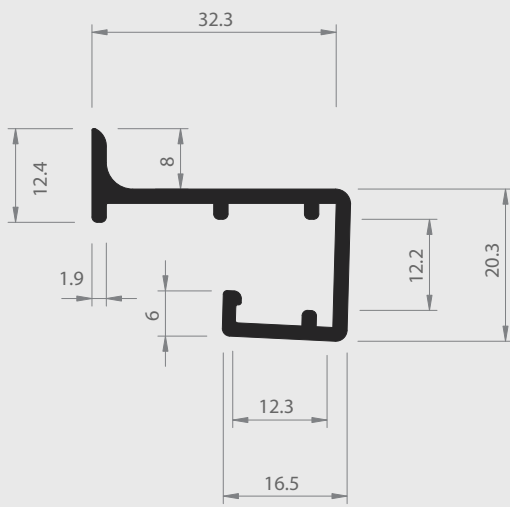

Nr. 35/32 H

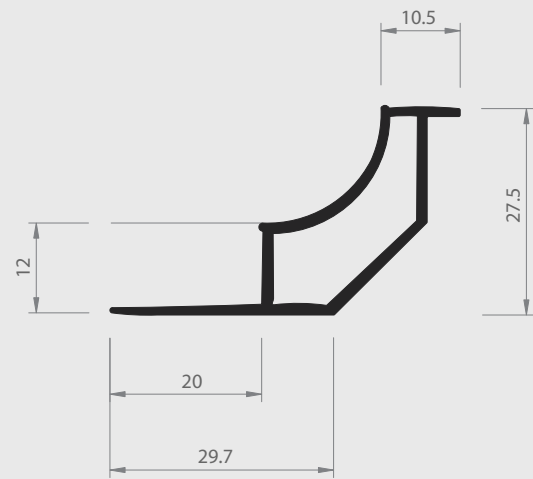

Nr. 26/06 H

= Hart PVC
 = Weich PVC | HH = Halhart PVC
 = Andere Kunststoffe

20 | SONDERPROFILE

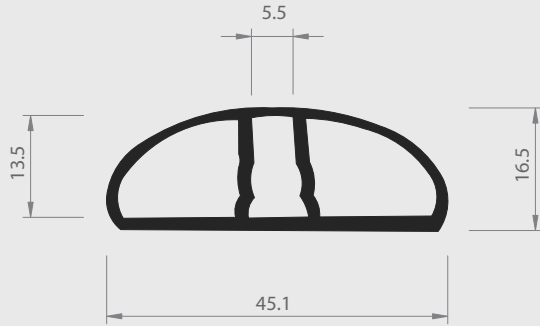

Nr. 54/46 H

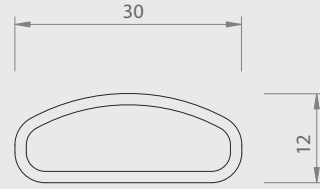

Nr. 54/09 TPU

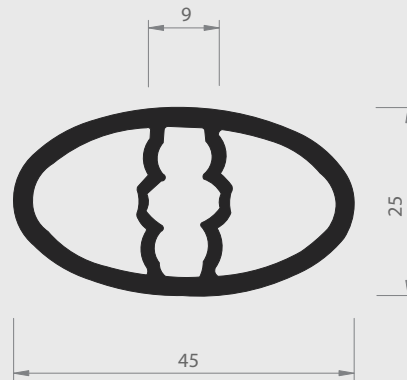

Nr. 54/45 H

■ = Hart PVC ■ = Weich PVC | HH = Halbhart PVC □ = Andere Kunststoffe

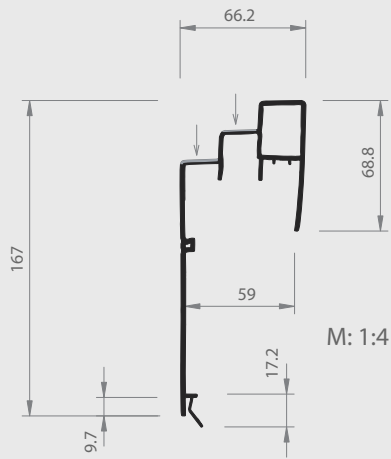

Nr. 22/84 H
zweifärbig

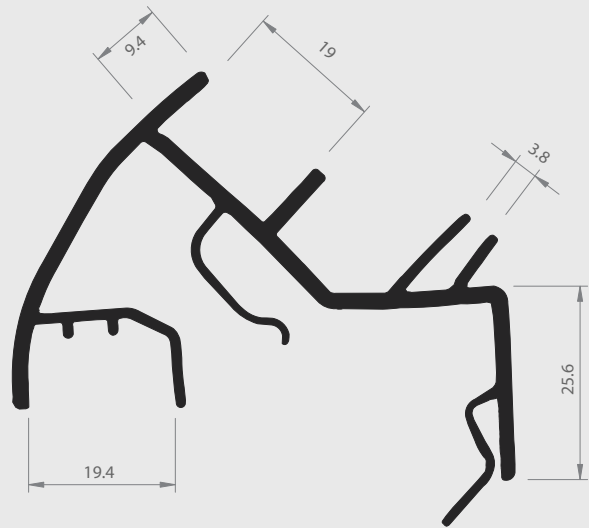

Nr. 22/83 H

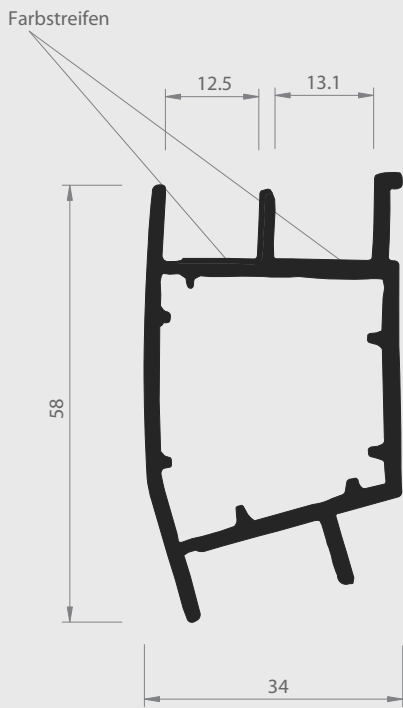

Nr. 22/85 H

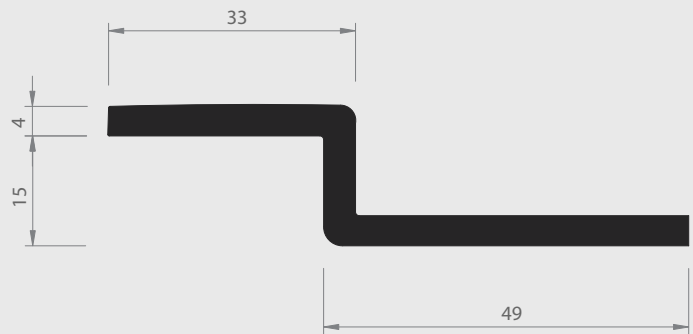

Nr. 14/64 H

= Hart PVC
 = Weich PVC | HH = Halbhart PVC
 = Andere Kunststoffe

20 | SONDERPROFILE

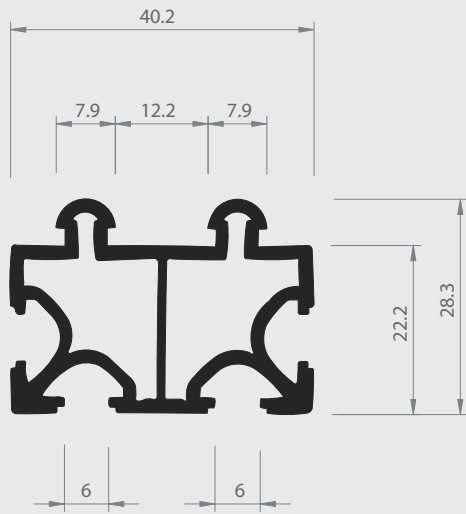

Nr. 24/21 H

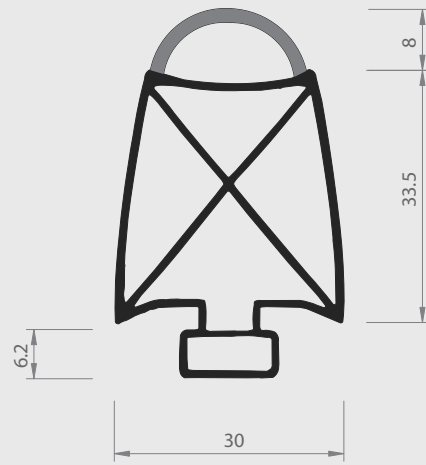

Nr. 62/84a H+W

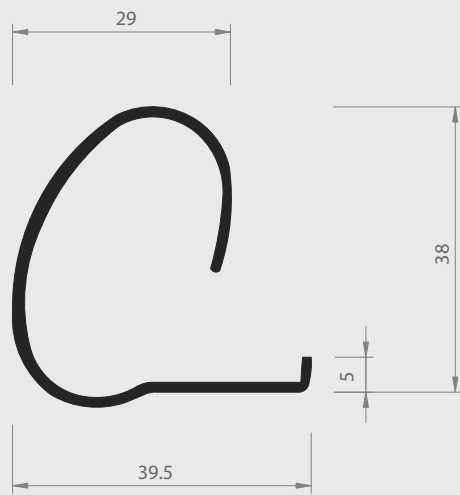

Nr. 06/28 H



Nr. 05/50 H+W

= Hart PVC
 = Weich PVC | HH = Halbhart PVC
 = Andere Kunststoffe

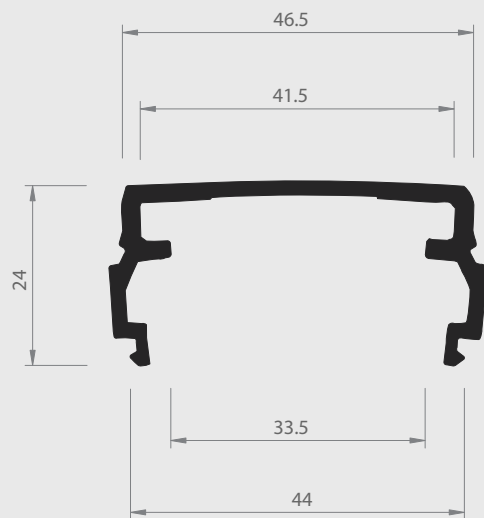

Nr. 28/18 H

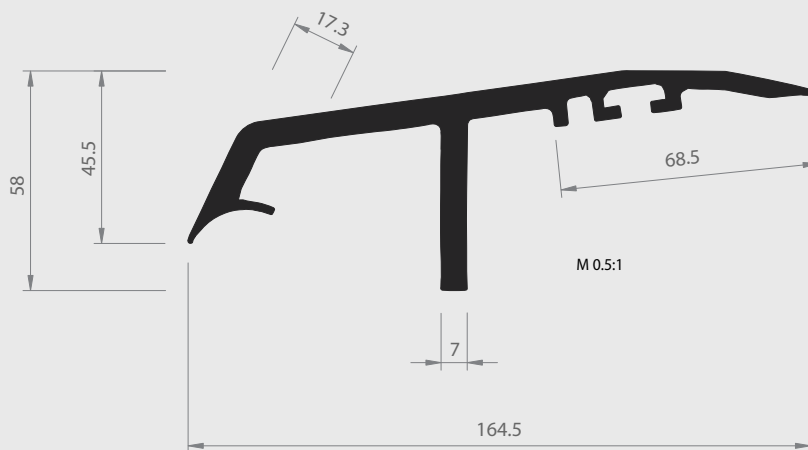

Nr. 22/67 H

■ = Hart PVC ■ = Weich PVC | HH = Halbhart PVC □ = Andere Kunststoffe

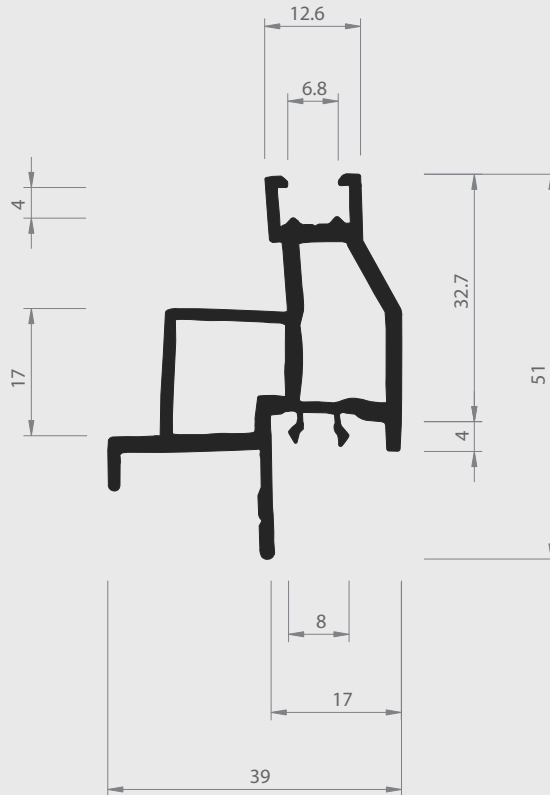

Nr. 23/85 H

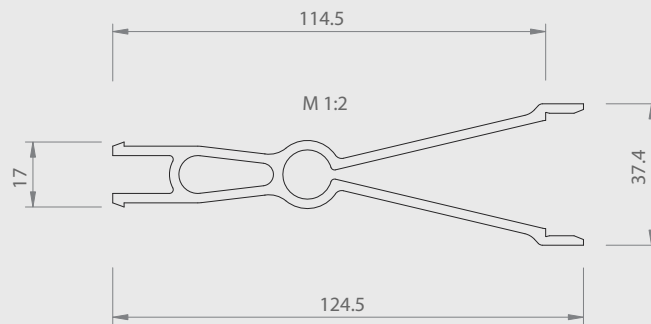

Nr. 11/55 PC

■ = Hart PVC ■ = Weich PVC | HH = Halbhart PVC □ = Andere Kunststoffe

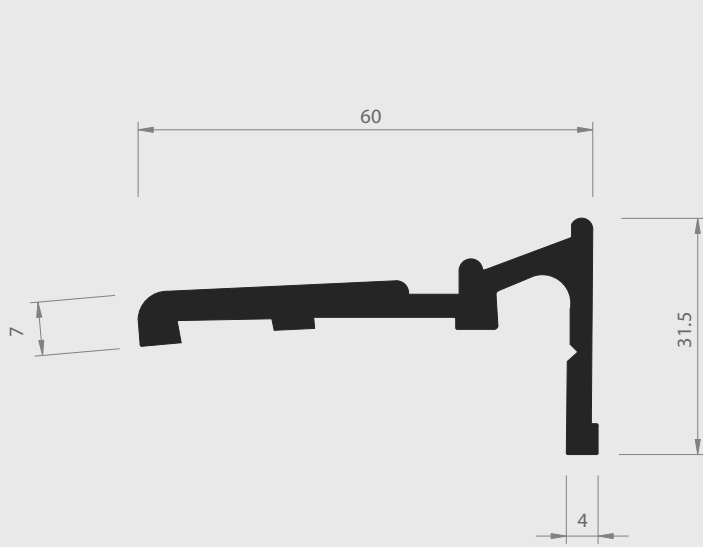

Nr. 35/39 H

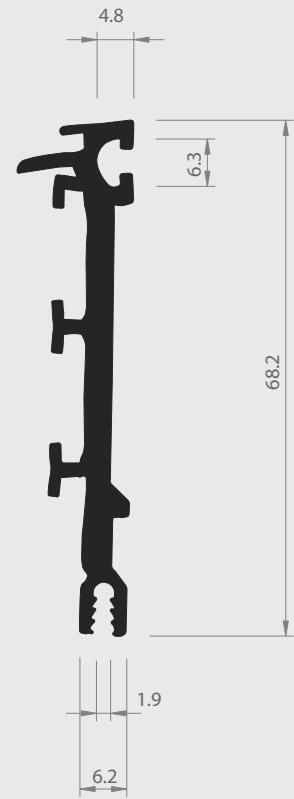

Nr. 31/07 H

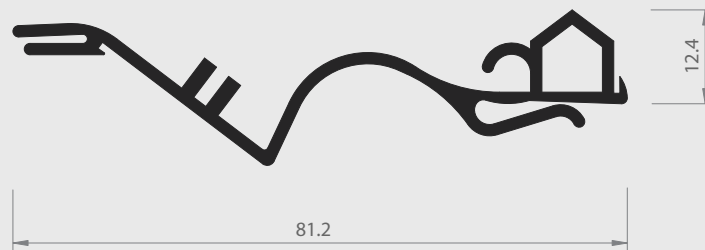

Nr. 09/68 H

= Hart PVC
 = Weich PVC | HH = Halbhart PVC
 = Andere Kunststoffe

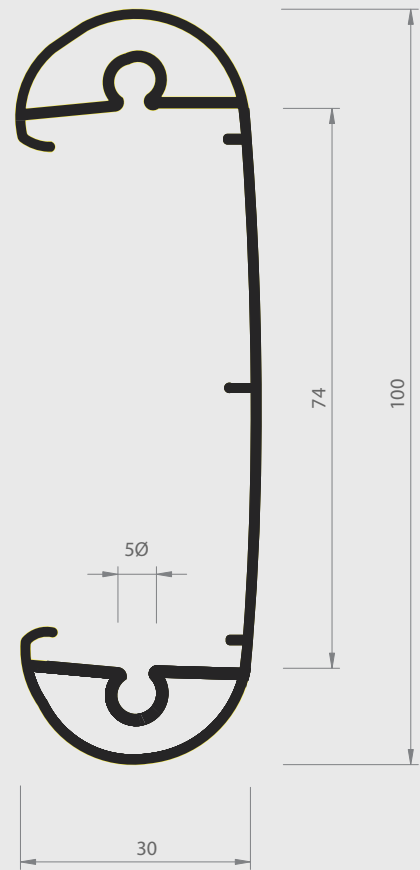
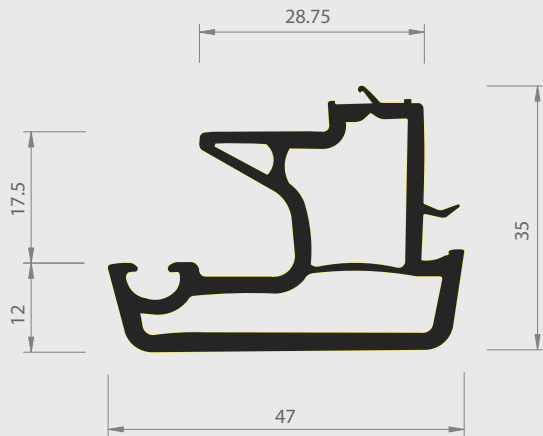
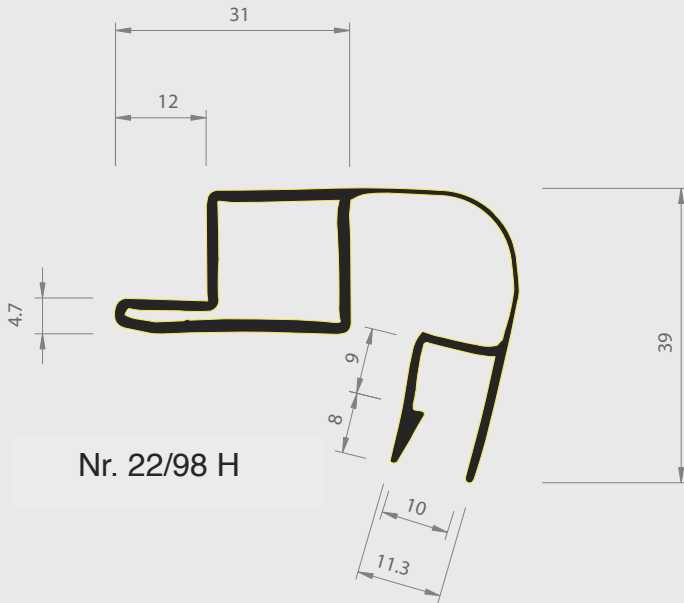

= Hart PVC
 = Weich PVC | HH = Halbhart PVC
 = Andere Kunststoffe

20 | SONDERPROFILE

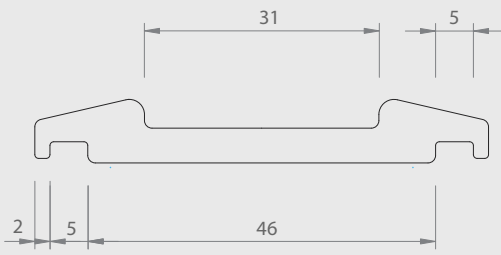

Nr. 31/12 HDPE

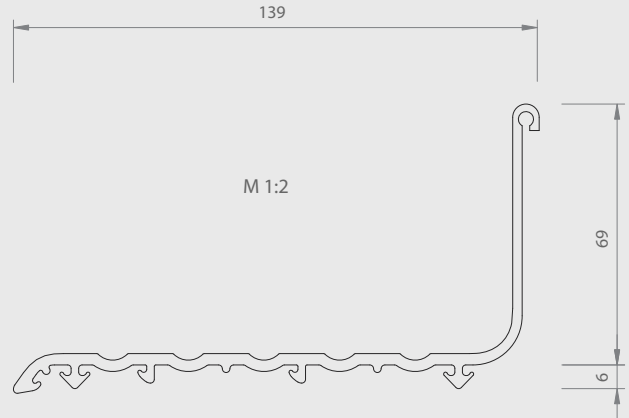

Nr. 32/01 TPO

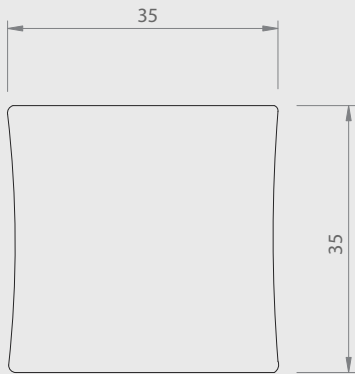

Nr. 06/47 PS

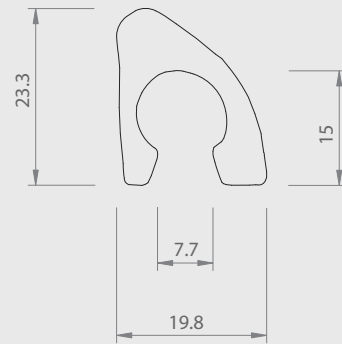

Nr. 16/89 HDPE

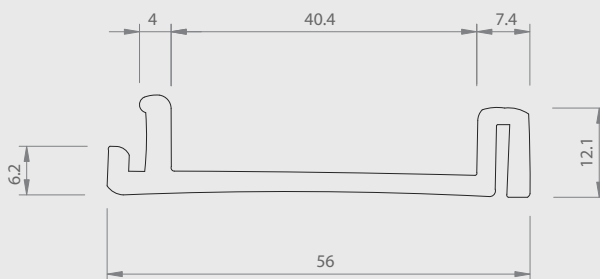

Nr. 31/02 HDPE

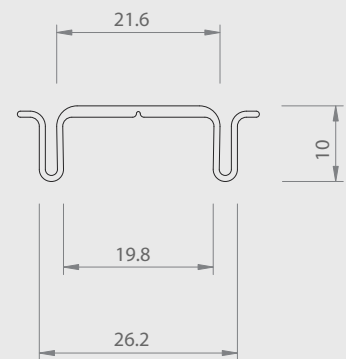

Nr. 24/22 ABS

= Hart PVC
 = Weich PVC | HH = Halbhart PVC
 = Andere Kunststoffe

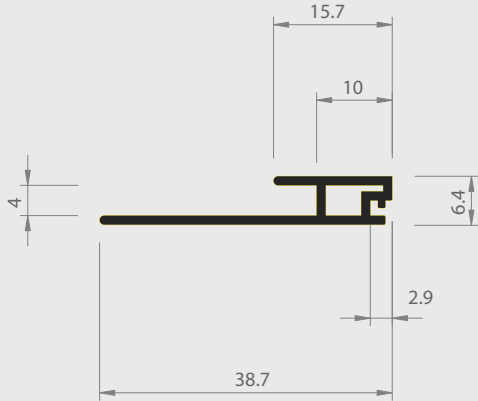

Nr. 05/46 H

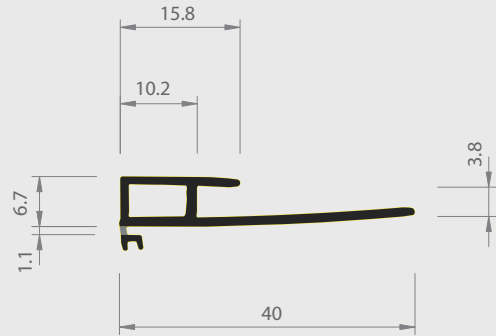

Nr. 05/45 H+W

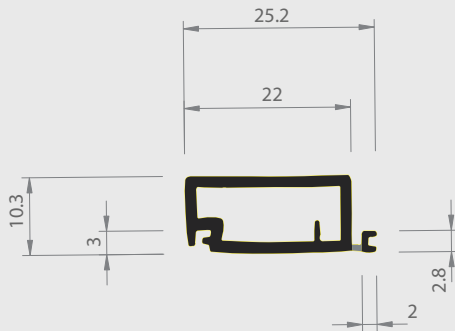

Nr. 05/47 H+W

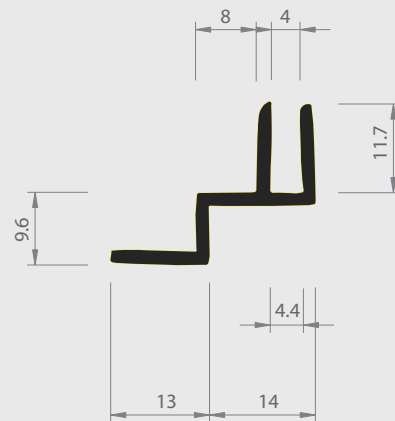

Nr. 39/15 H

= Hart PVC
 = Weich PVC | HH = Halbhart PVC
 = Andere Kunststoffe

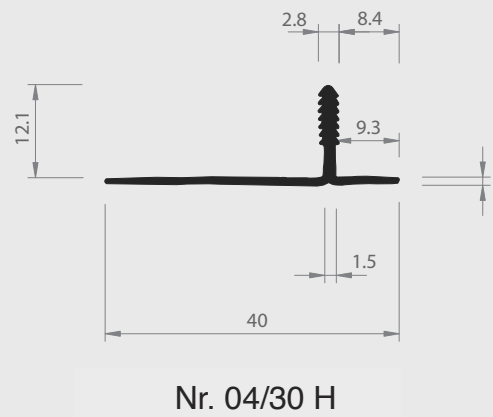
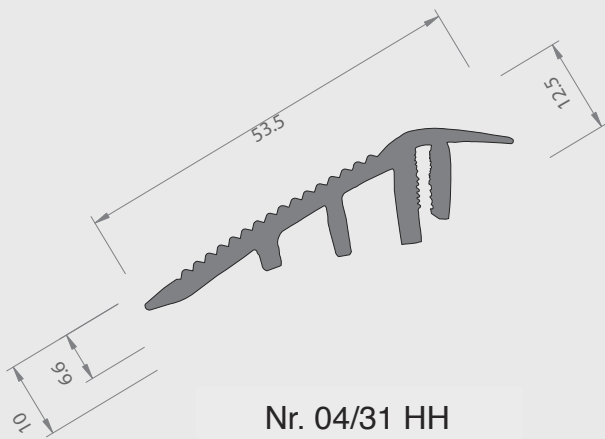
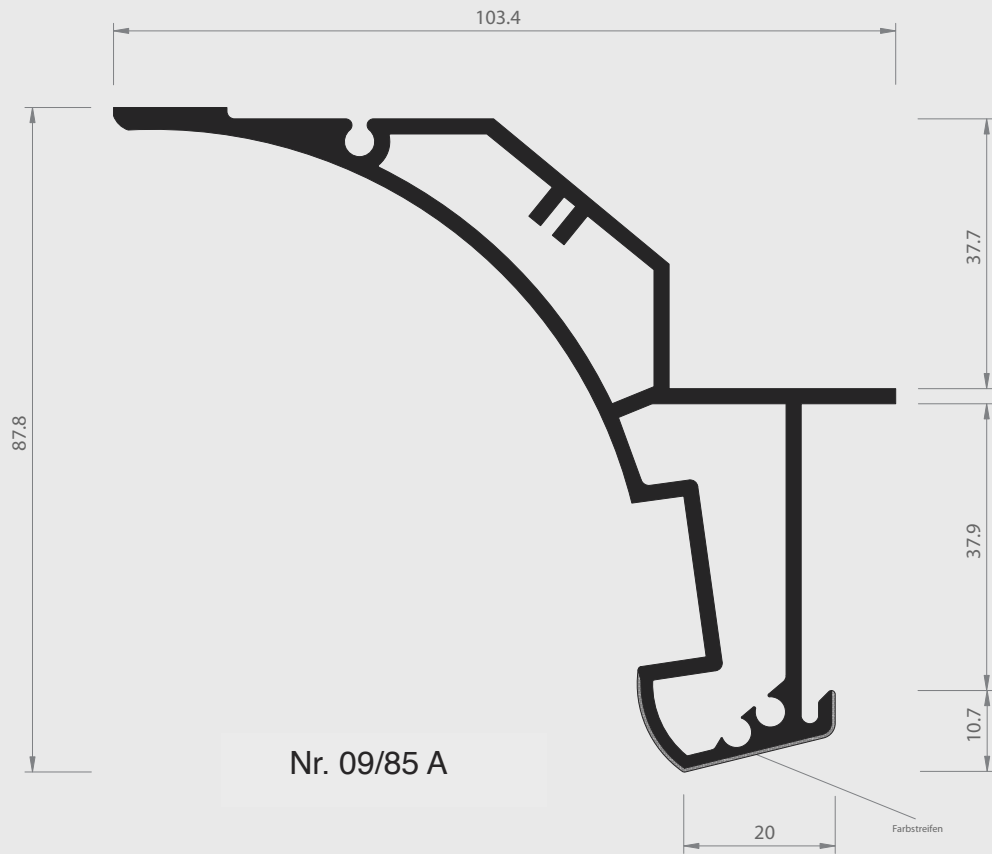

= Hart PVC
 = Weich PVC | HH = Halbhart PVC
 = Andere Kunststoffe

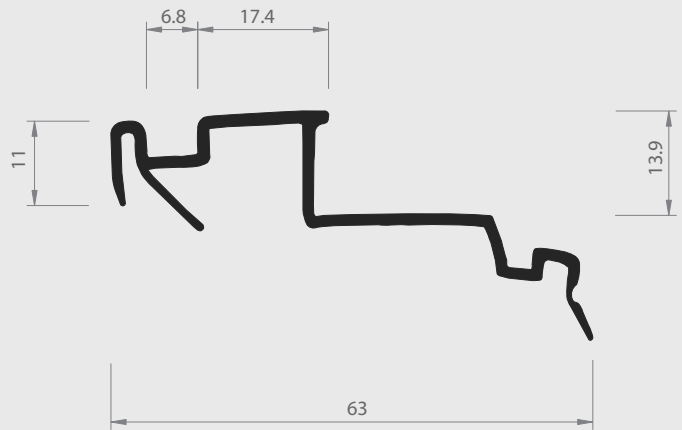

Nr. 23/77 H

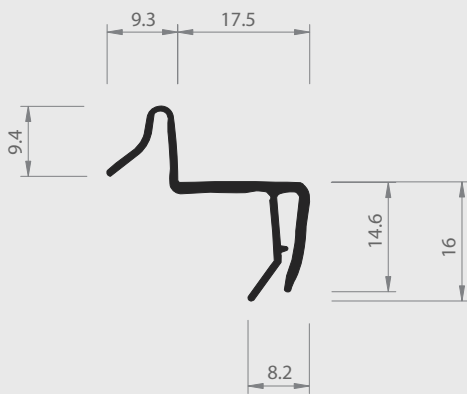

Nr. 23/78 H

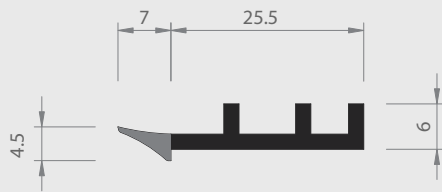

Nr. 22/23 H+W

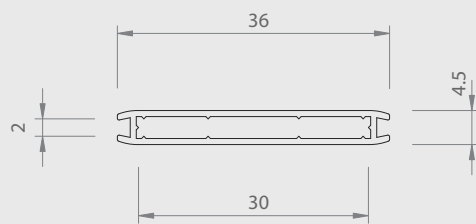

Nr. 17/33 ABS

= Hart PVC
 = Weich PVC | HH = Halbhart PVC
 = Andere Kunststoffe

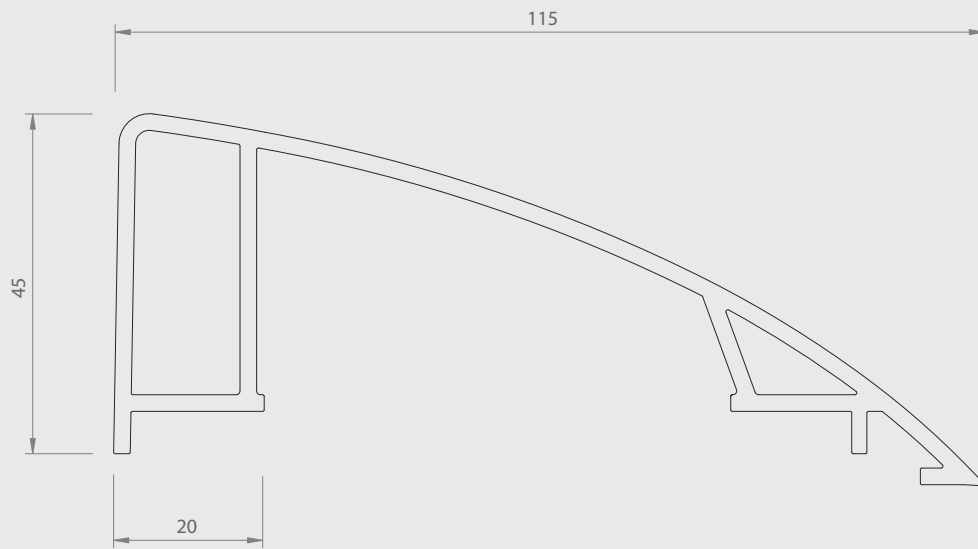

Nr. 33/20 ABS

■ = Hart PVC ■ = Weich PVC | HH = Halbhart PVC □ = Andere Kunststoffe

20 | SONDERPROFILE

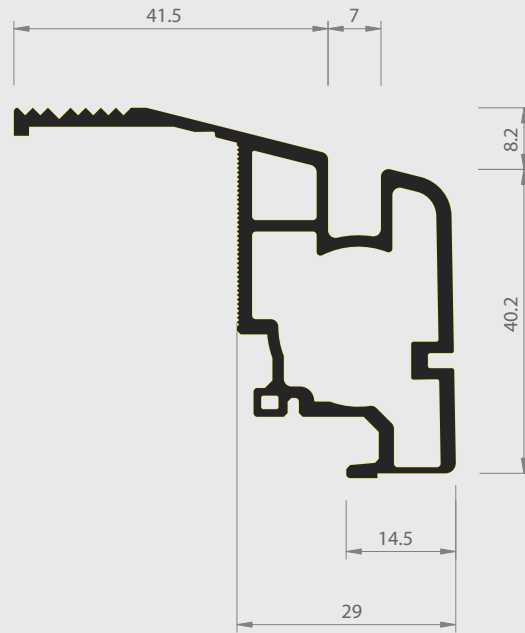

Nr. 23/81 H

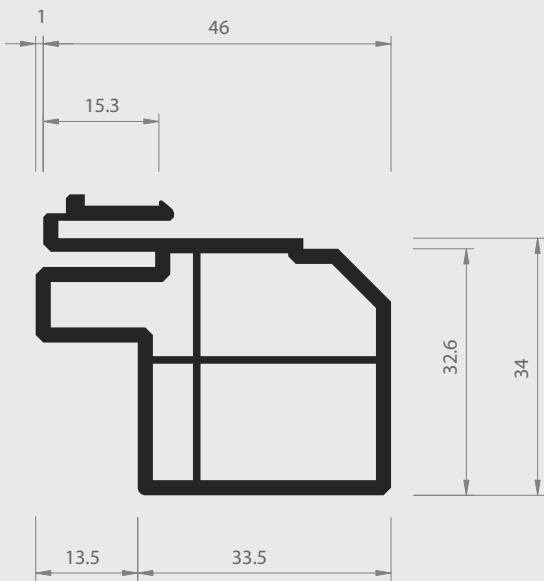

Nr. 23/80 H

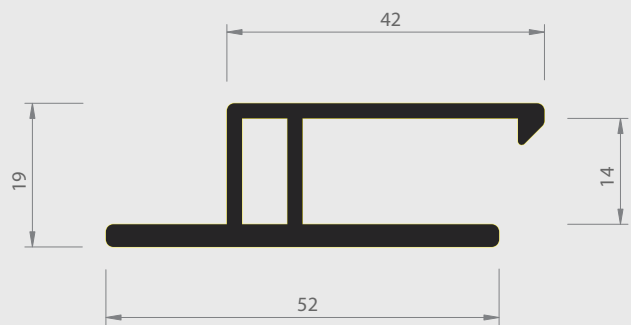

Nr. 17/05 H

= Hart PVC
 = Weich PVC | HH = Halbhart PVC
 = Andere Kunststoffe

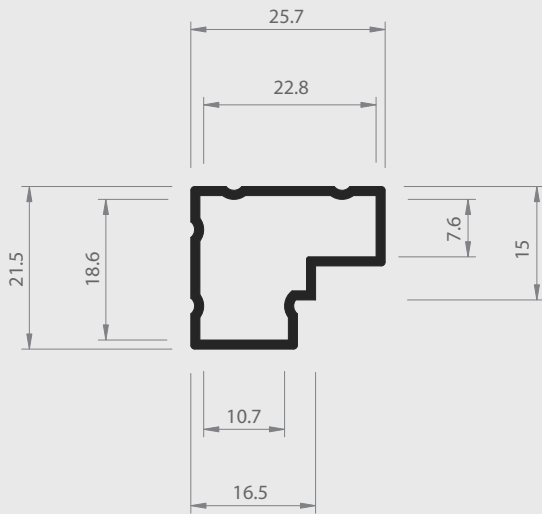

Nr. 22/25 H

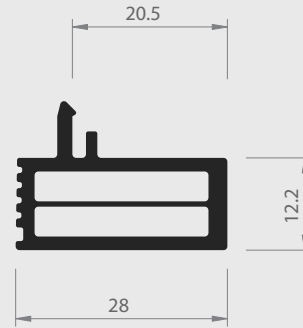

Nr. 17/90 H

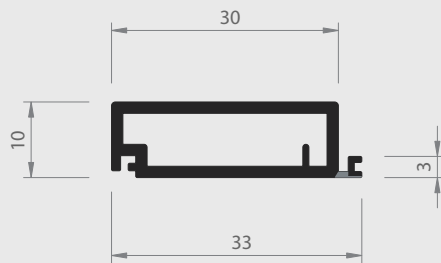

Nr. 05/48 H+W

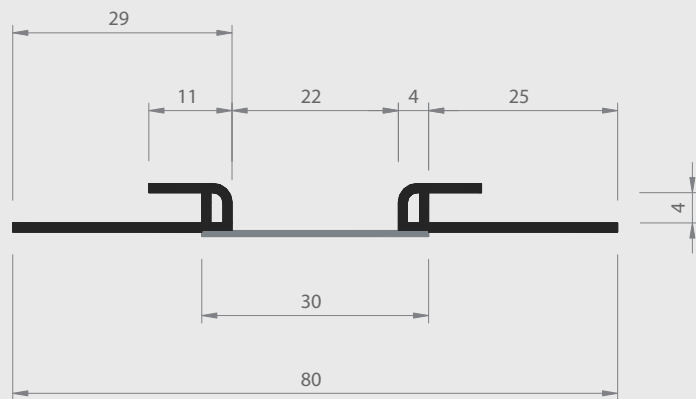

Nr. 05/49 H+W

= Hart PVC
 = Weich PVC | HH = Halbhart PVC
 = Andere Kunststoffe

20 | SONDERPROFILE

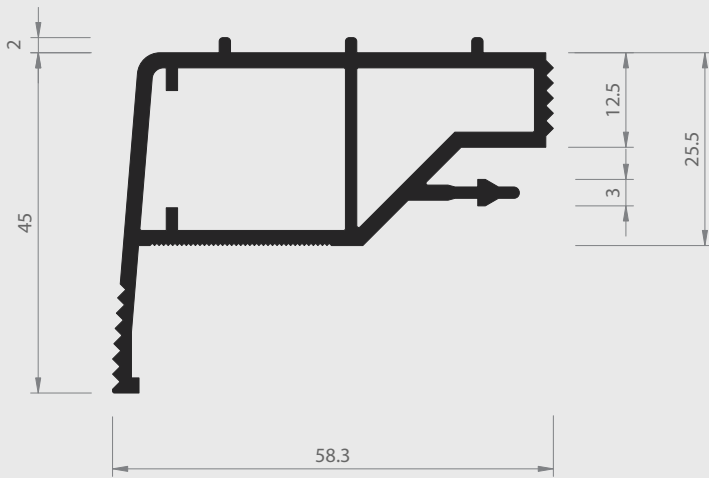

Nr. 23/73 H

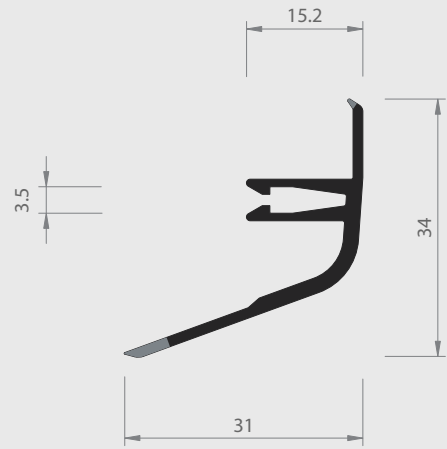

Nr. 23/74 H+W

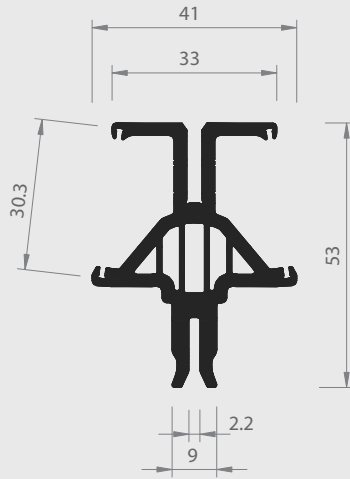

Nr. 27/23 H

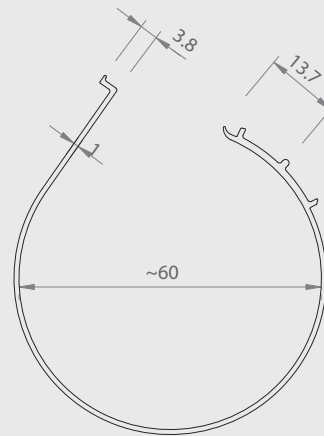

Nr. 54/39 PE-HD

= Hart PVC
 = Weich PVC | HH = Halbhart PVC
 = Andere Kunststoffe

20 | SONDERPROFILE

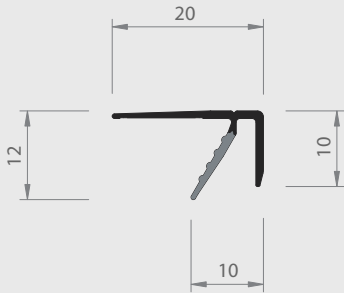

Nr. 23/71 H+HH

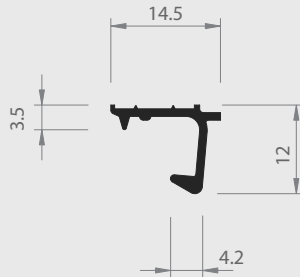

Nr. 07/08 H

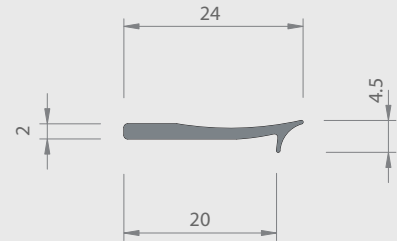

Nr. 60/65 HH

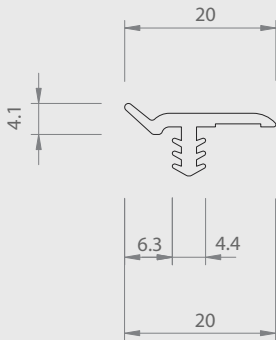

Nr. 07/49 TPE

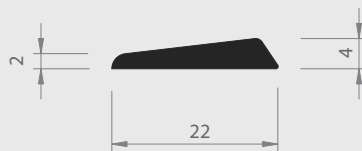

Nr. 11/03 H

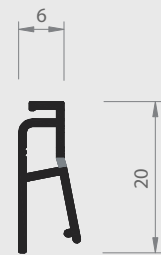

Nr. 16/13 H+W

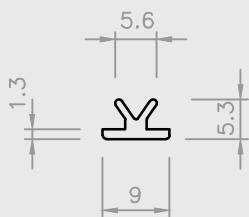

Nr. 33/25 HDPE

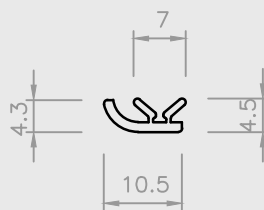

Nr. 33/26 HDPE

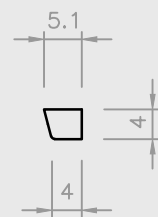

Nr. 33/27 HDPE

= Hart PVC
 = Weich PVC | HH = Halbhart PVC
 = Andere Kunststoffe

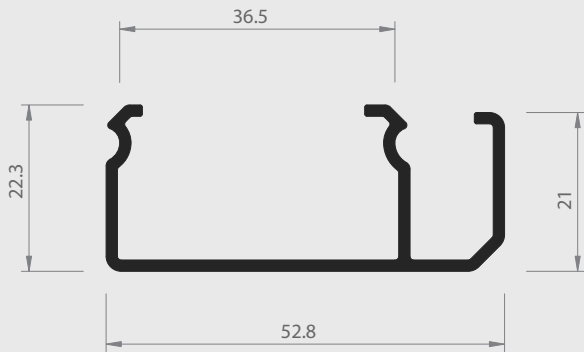

Nr. 16/57 H

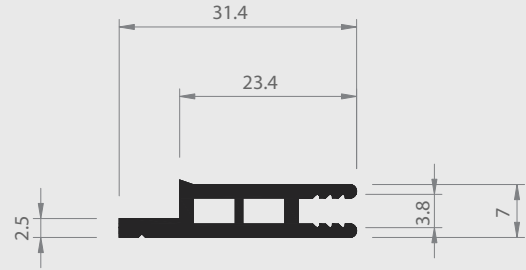

Nr. 07/48 H

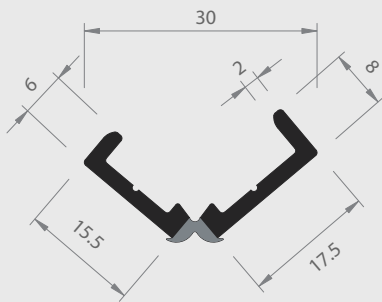

Nr. 07/07 H+W

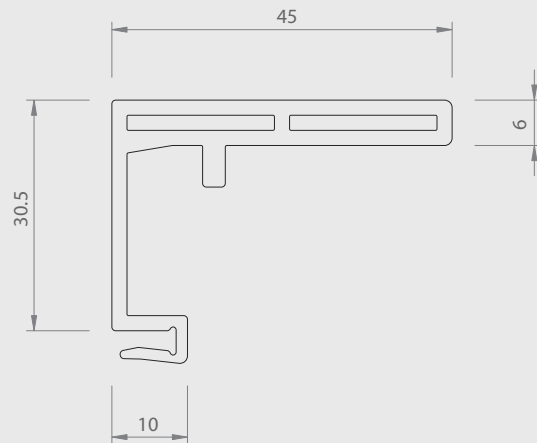

Nr. 05/66 ABS

= Hart PVC
 = Weich PVC | HH = Halbhart PVC
 = Andere Kunststoffe

20 | SONDERPROFILE

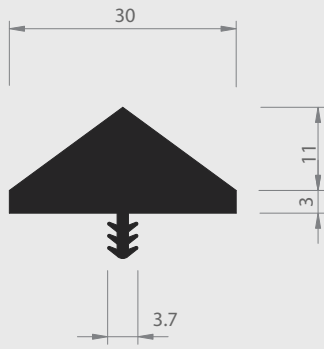

Nr. 23/22 H

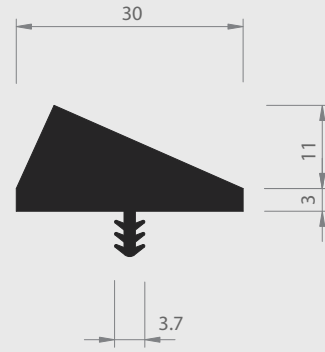

Nr. 23/21 H

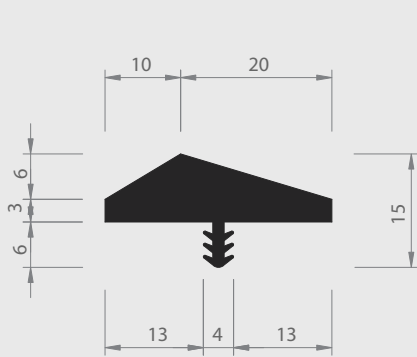

Nr. 23/23 H

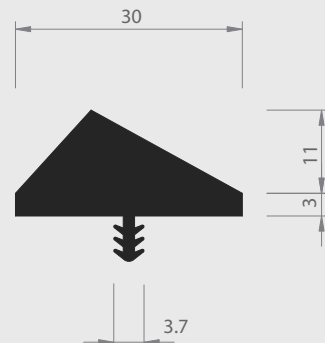

Nr. 23/20 H

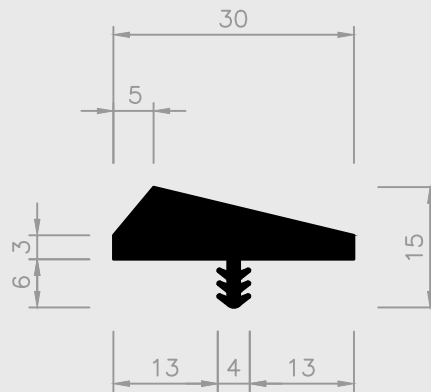

Nr. 23/35 H

= Hart PVC
 = Weich PVC | HH = Halbhart PVC
 = Andere Kunststoffe

20 | SONDERPROFILE

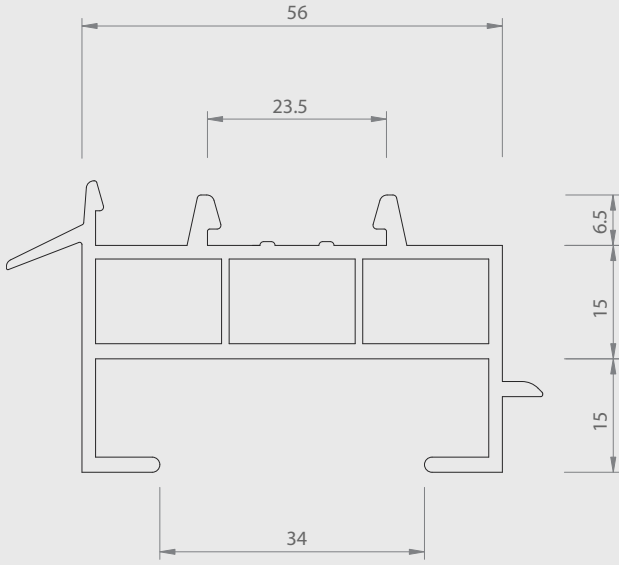

Nr. 21/97 PP

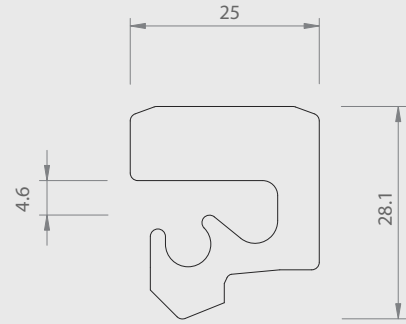

Nr. 08/03 TPU

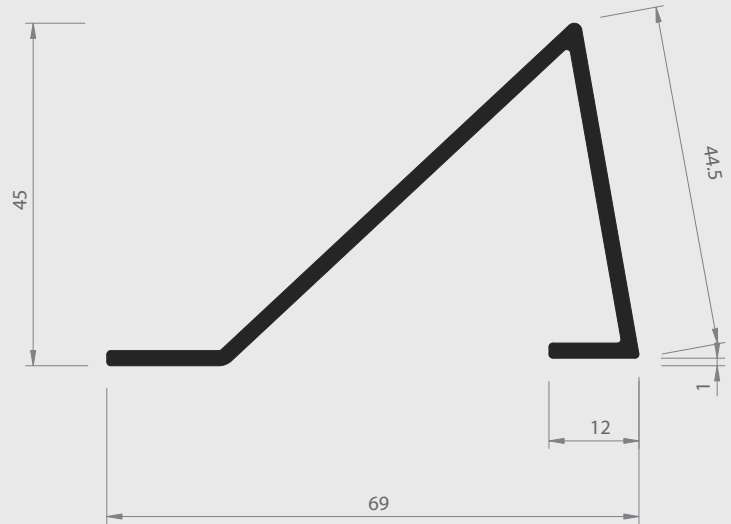

Nr. 23/47 H

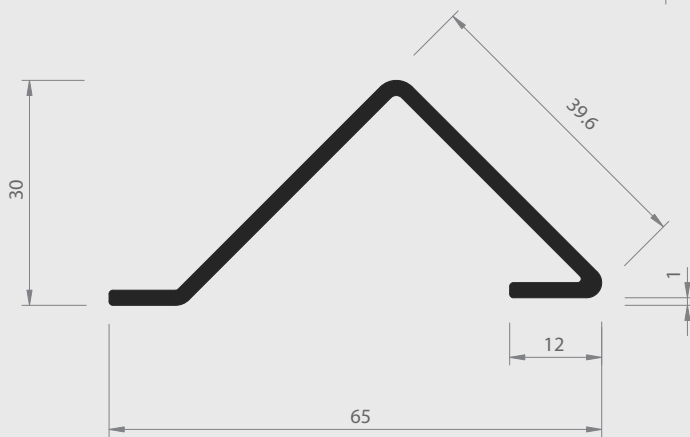

Nr. 23/46 H

= Hart PVC
 = Weich PVC | HH = Halbhart PVC
 = Andere Kunststoffe

20 | SONDERPROFILE

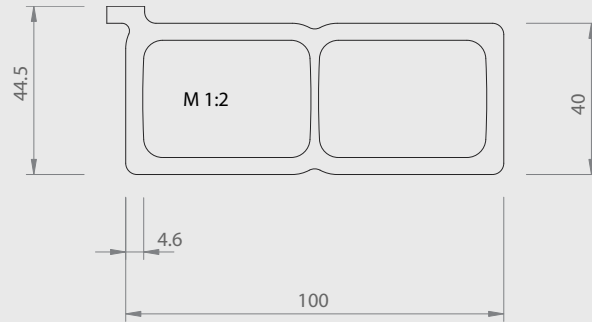

Nr. 07/46 PP

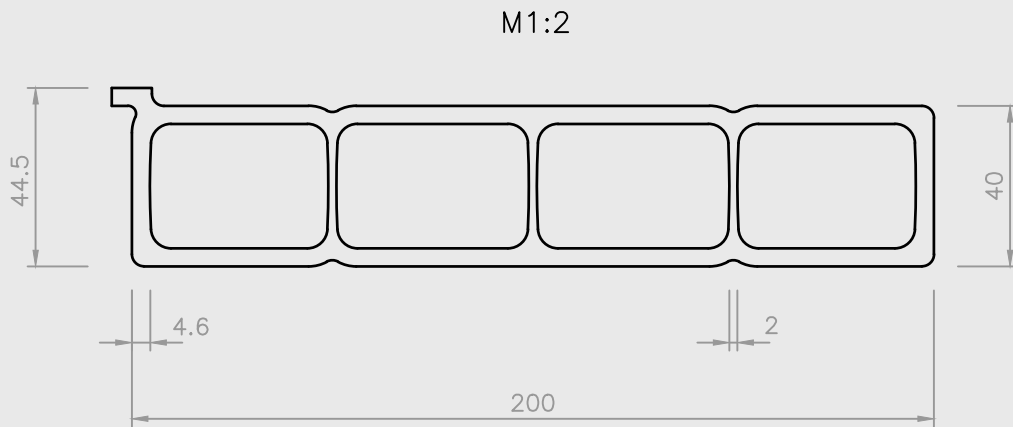

Nr. 07/47A PP

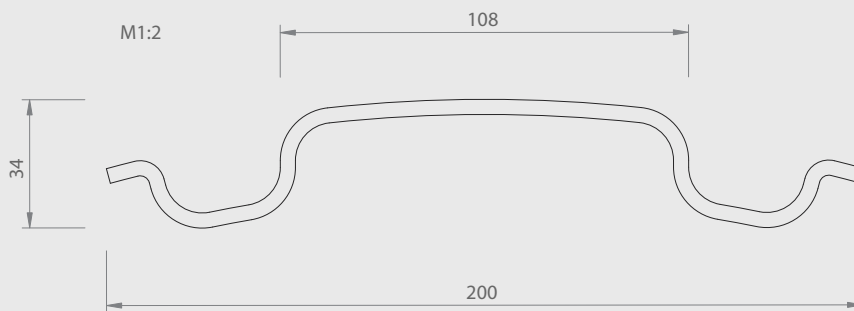

Nr. 07/50 PP

■ = Hart PVC ■ = Weich PVC | HH = Halbhart PVC □ = Andere Kunststoffe

20 | SONDERPROFILE

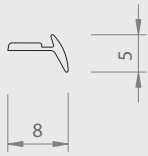

Nr. 07/13 TPE

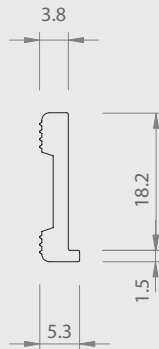

Nr. 21/02 TPE

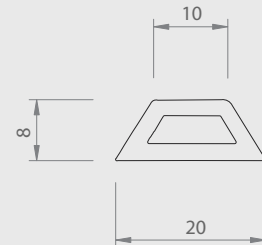

Nr. 61/43 PC

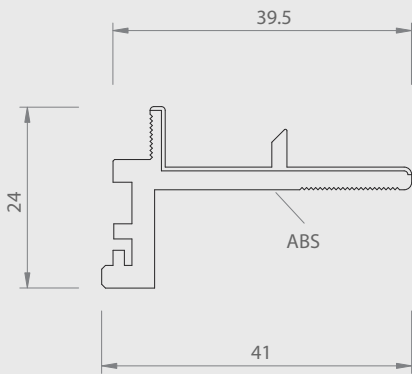

Nr. 26/40 ABS-PS

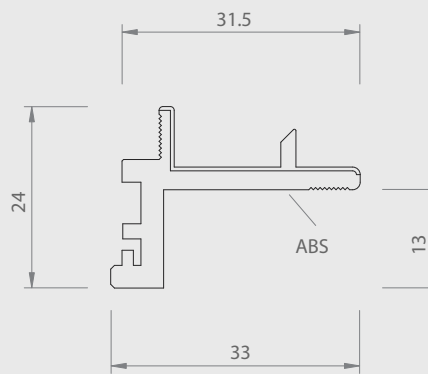

Nr. 26/39 ABS-PS

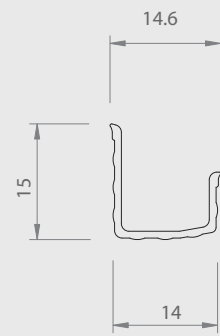

Nr. 26/38 PS

■ = Hart PVC

■ = Weich PVC | HH = Halbhart PVC

□ = Andere Kunststoffe

20 | SONDERPROFILE

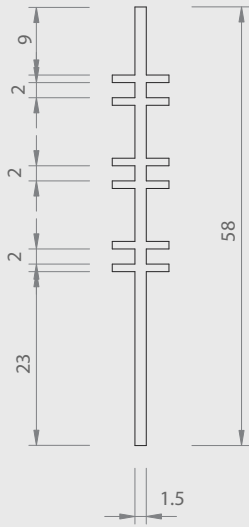

Nr. 25/53 PMMA

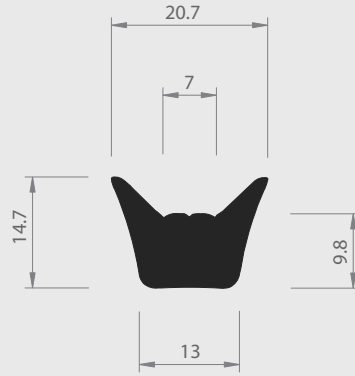

Nr. 25/02 H

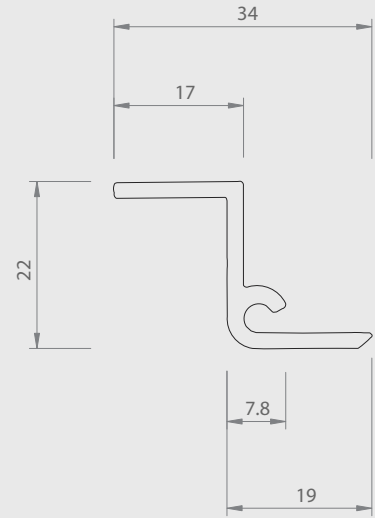

Nr. 16/19 PC

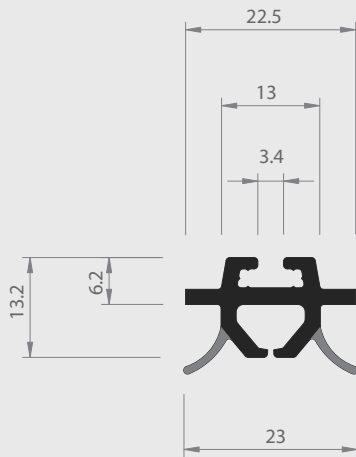

Nr. 17/49 H+W

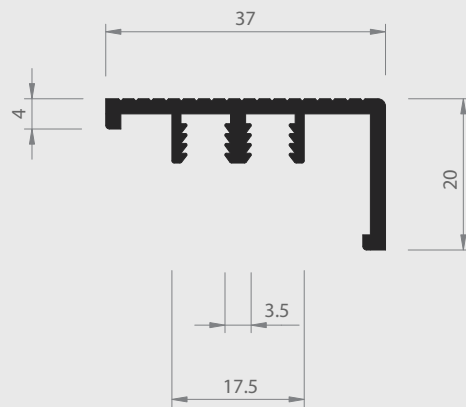

Nr. 35/41 H

= Hart PVC
 = Weich PVC | HH = Halbhart PVC
 = Andere Kunststoffe

20 | SONDERPROFILE



Nr. 27/37 H

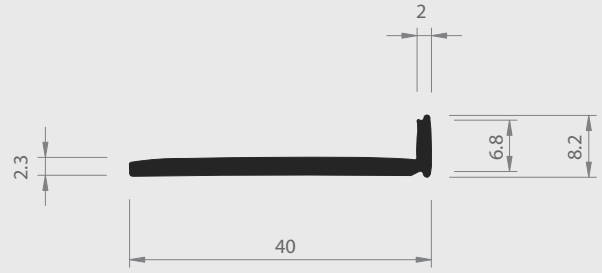

Nr. 05/65 H

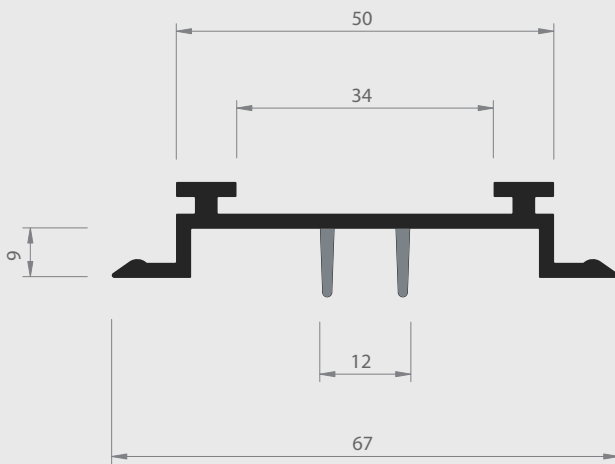

Nr. 06/12 H+W

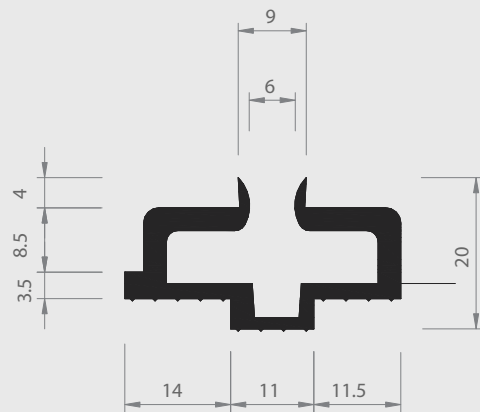

Nr. 21/39 H

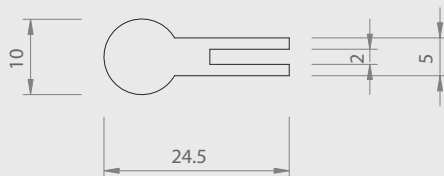

Nr. 34/35 TPU

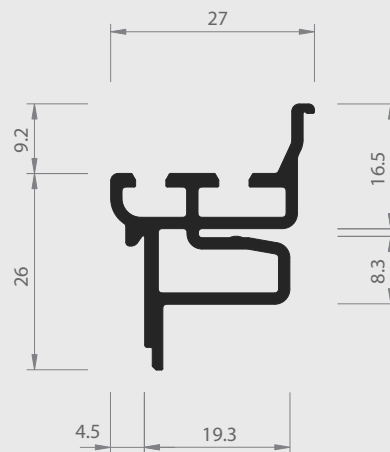

Nr. 23/83 H

= Hart PVC
 = Weich PVC | HH = Halbhart PVC
 = Andere Kunststoffe

20 | SONDERPROFILE

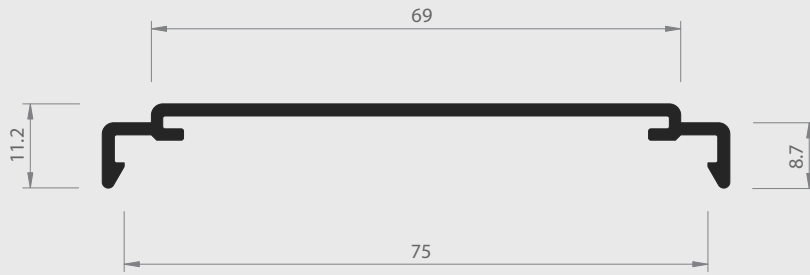

Nr. 16/62 H

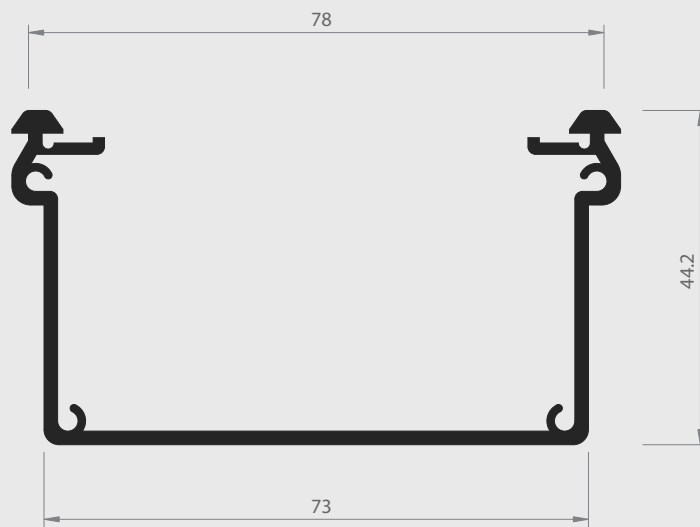

Nr. 16/61 H

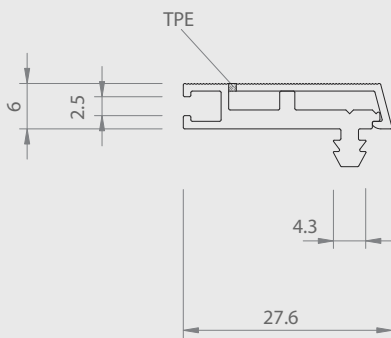

Nr. 26/31 ABS/TPE

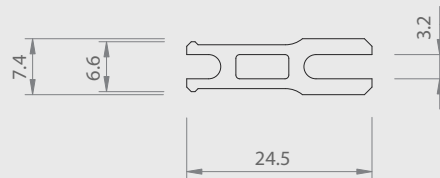

Nr. 09/55 PC/ABS

= Hart PVC
 = Weich PVC | HH = Halbhart PVC
 = Andere Kunststoffe

20 | SONDERPROFILE

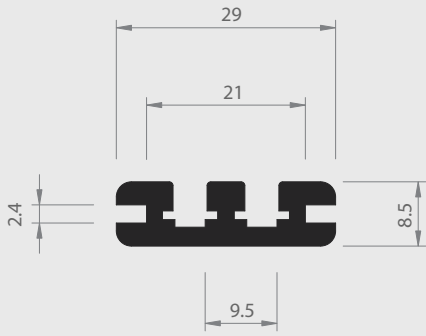

Nr. 17/17 H

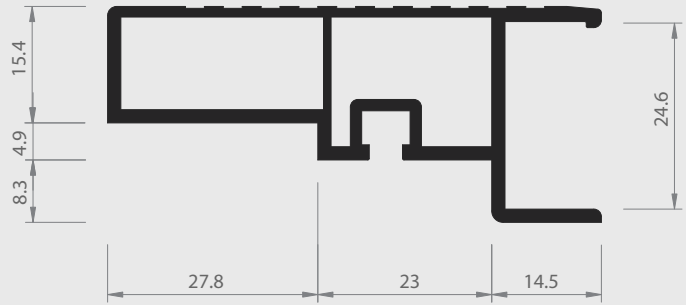

Nr. 23/69 H

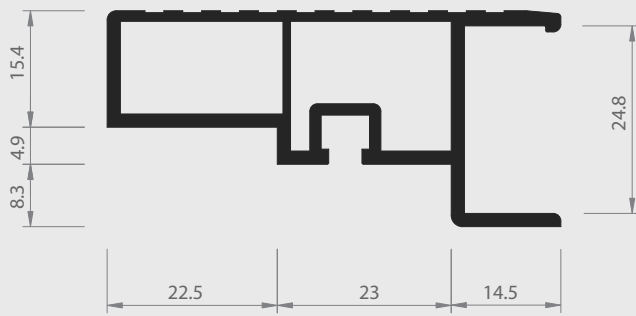

Nr. 23/68 H

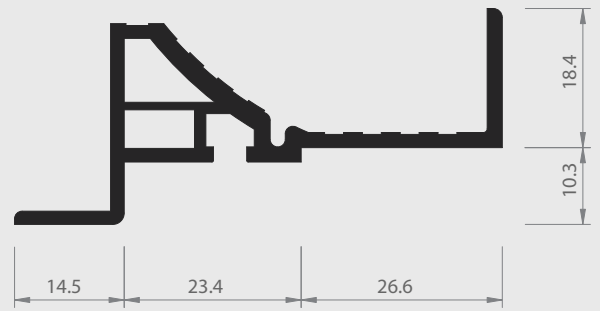

Nr. 23/70 H

= Hart PVC
 = Weich PVC | HH = Halbhart PVC
 = Andere Kunststoffe

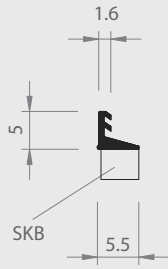

Nr. 05/22a H

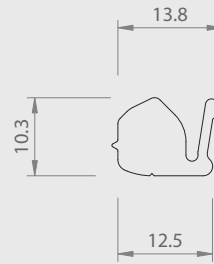

Nr. 25/13 PC/GF 15

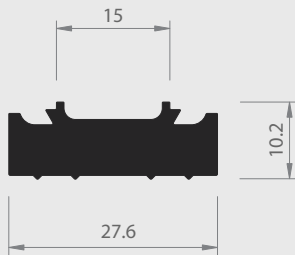

Nr. 09/52 H

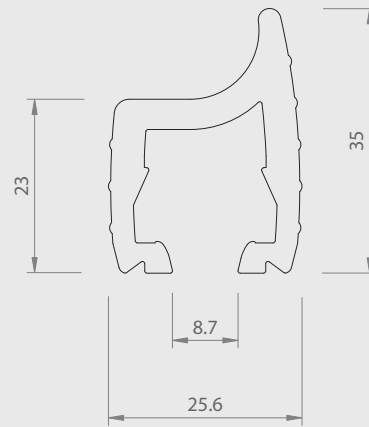

Nr. 22/51 HDPE

= Hart PVC
 = Weich PVC | HH = Halbhart PVC
 = Andere Kunststoffe

20 | SONDERPROFILE

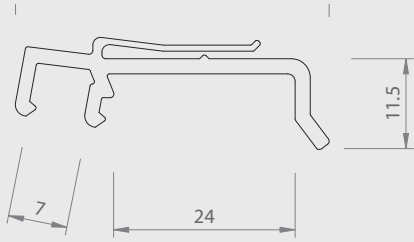

Nr. 09/71 PS

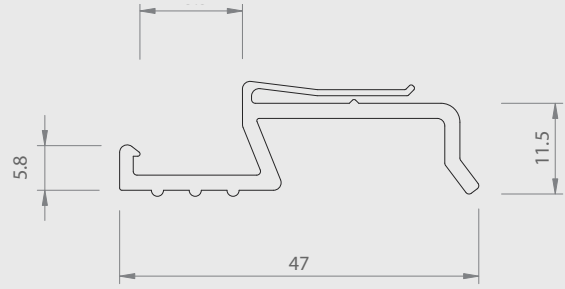

Nr. 09/70 PS

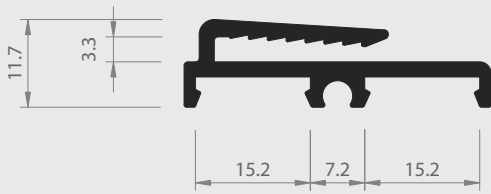

Nr. 30/38 H

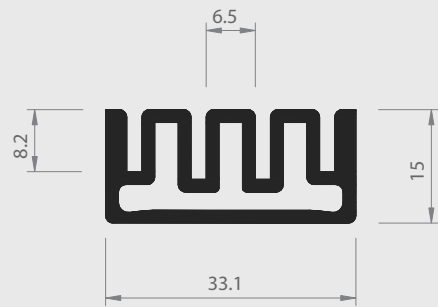

Nr. 17/57 H

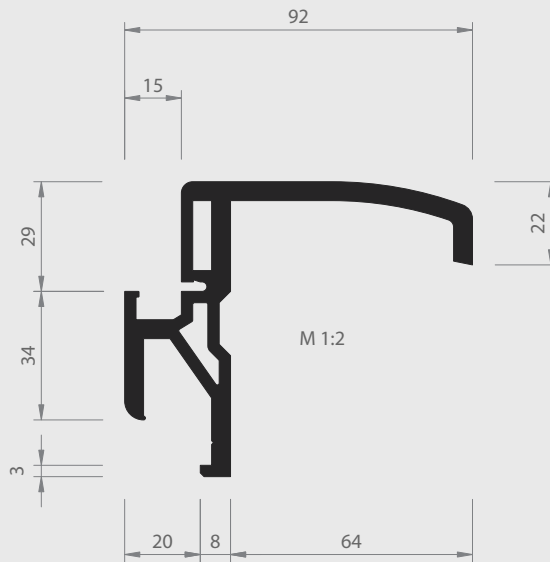

Nr. 28/51 H

= Hart PVC
 = Weich PVC | HH = Halbhart PVC
 = Andere Kunststoffe

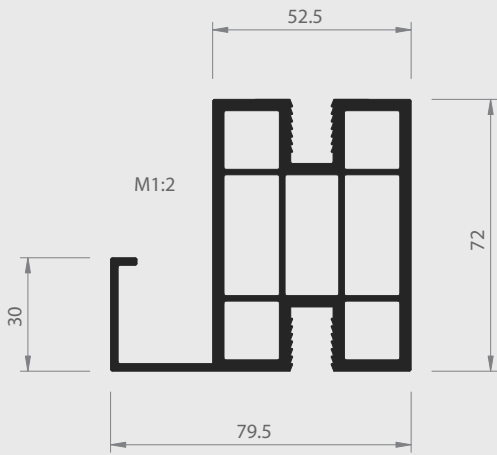

Nr. 49/07 H

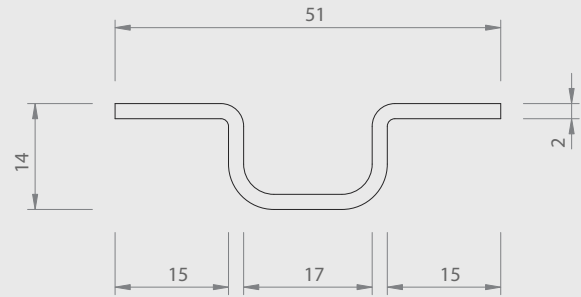

Nr. 25/17 ABS

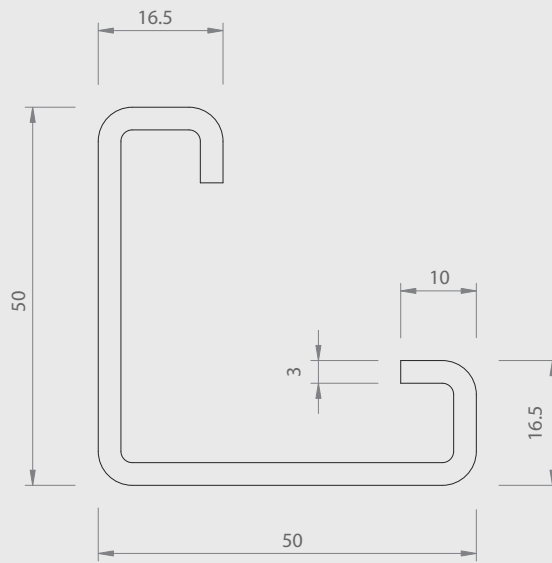

Nr. 20/57 HDPE

= Hart PVC
 = Weich PVC | HH = Halbhart PVC
 = Andere Kunststoffe

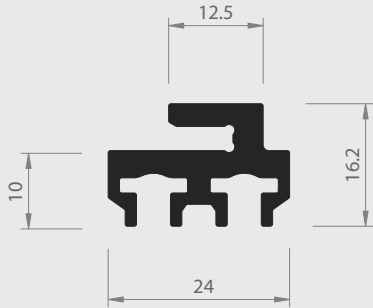

Nr. 22/68 H

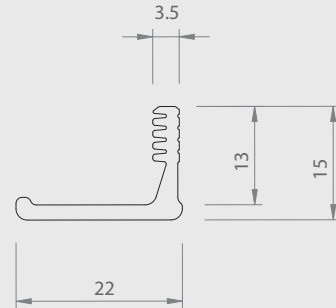

Nr. 17/71 ABS

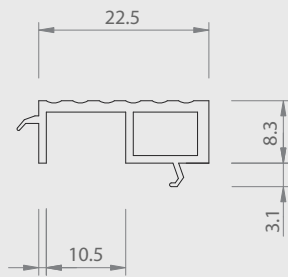

Nr. 26/52 PS

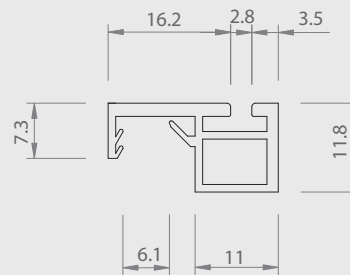

Nr. 26/53 PS

= Hart PVC
 = Weich PVC | HH = Halbhart PVC
 = Andere Kunststoffe

20 | SONDERPROFILE

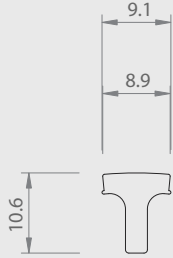

Nr. 11/56 HDPE

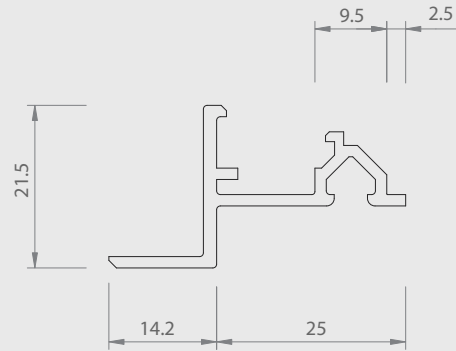

Nr. 21/44 ABS

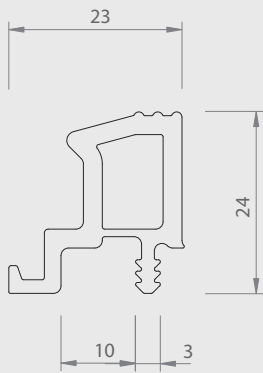

Nr. 26/51a PS

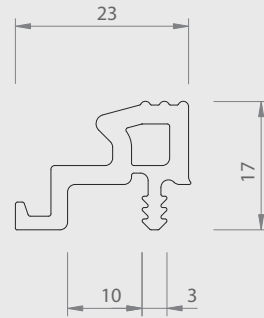

Nr. 26/50a PS

■ = Hart PVC

■ = Weich PVC | HH = Halbhart PVC

■ = Andere Kunststoffe

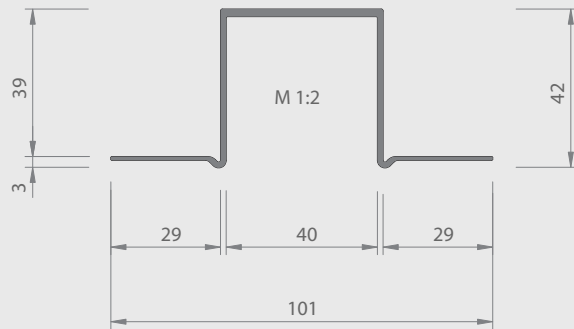

Nr. 23/64 HH

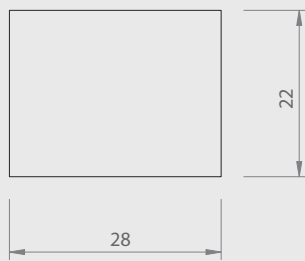

Nr. 06/52 HDPE-Gummi

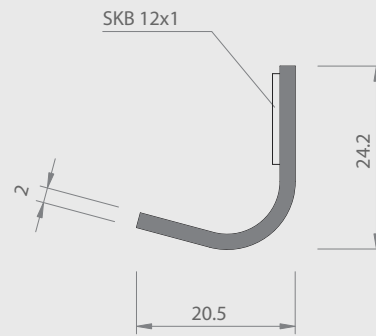

Nr. 25/18 HH

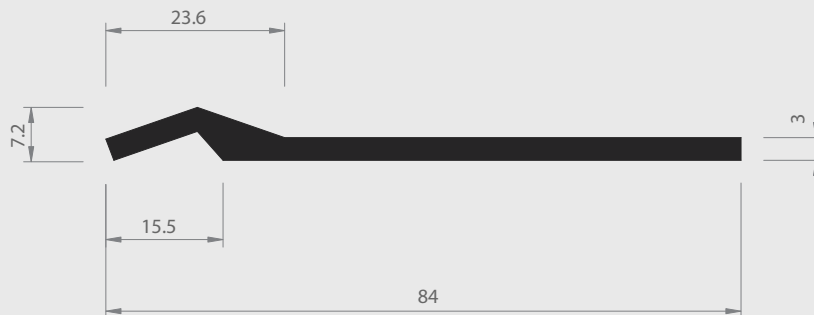

Nr. 07/51 H

= Hart PVC
 = Weich PVC | HH = Halbhart PVC
 = Andere Kunststoffe

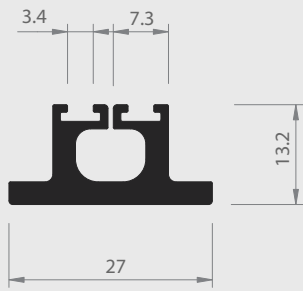

Nr. 09/57 H

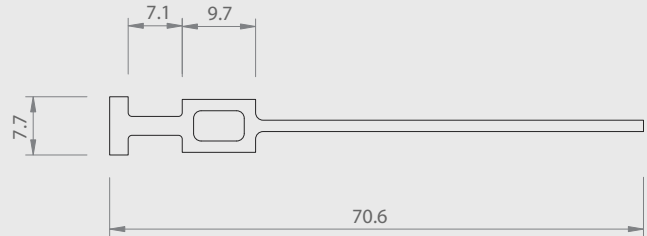

Nr. 54/30 PPE-PS-Blend Q 433

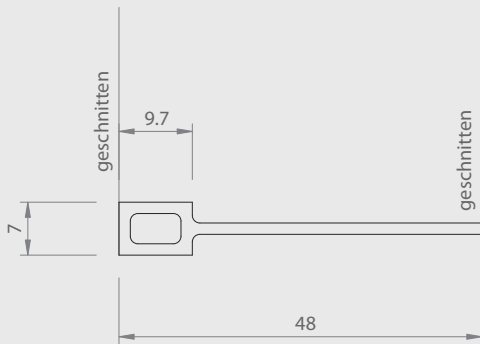

Nr. 54/30a PPE-PS-Blend

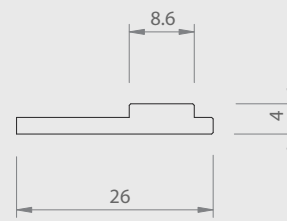

Nr. 54/38 PPE-PS

= Hart PVC
 = Weich PVC | HH = Halbhart PVC
 = Andere Kunststoffe

20 | SONDERPROFILE

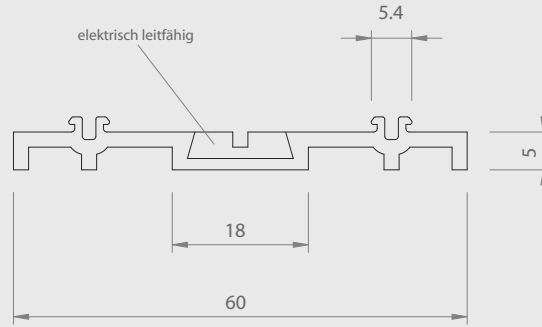

Nr. 20/37 HDPE



Nr. 22/69 ABS

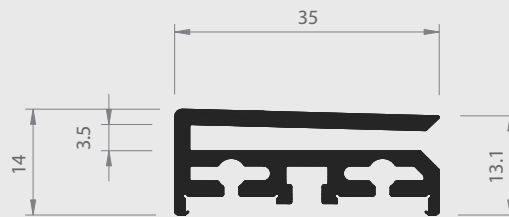

Nr. 33/21 H

■ = Hart PVC ■ = Weich PVC | HH = Halbhart PVC □ = Andere Kunststoffe

20 | SONDERPROFILE

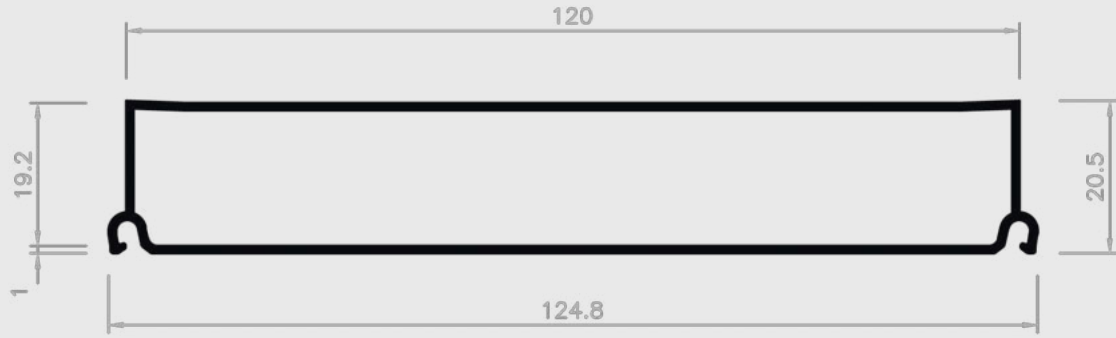

Nr. 43/2 H

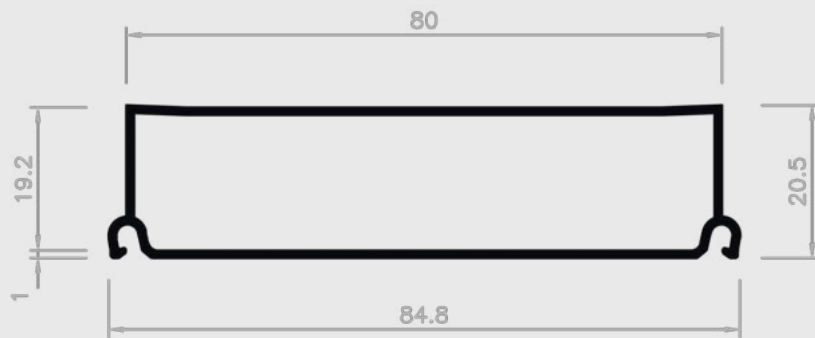

Nr. 43/1 H

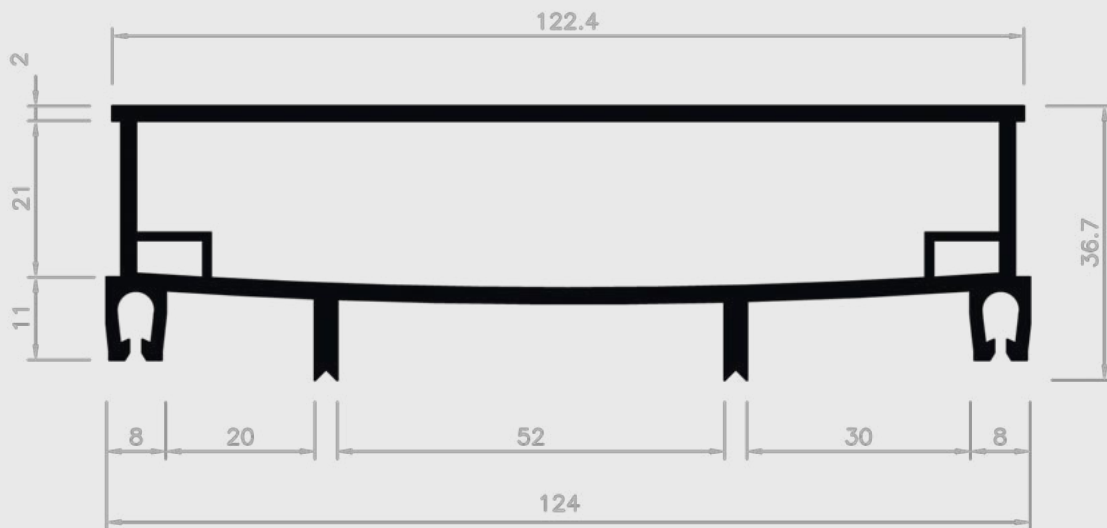

Nr. 43/3 H

= Hart PVC
 = Weich PVC | HH = Halbhart PVC
 = Andere Kunststoffe

20 | SONDERPROFILE

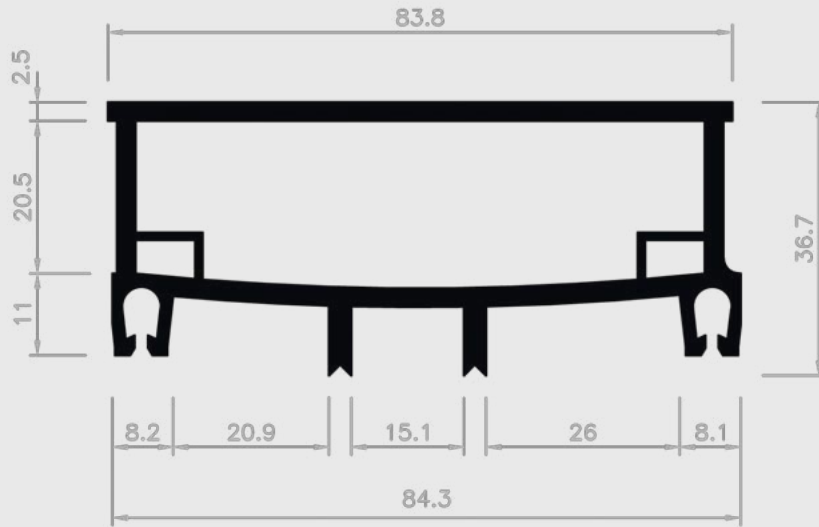

Nr. 43/4 H

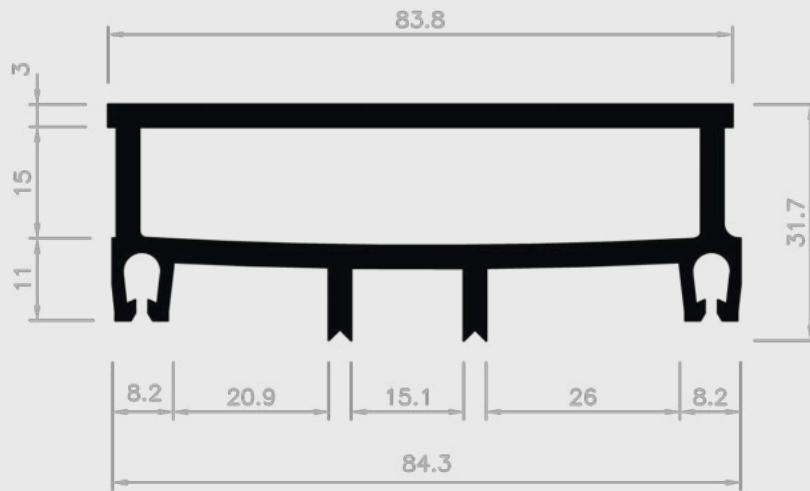

Nr. 43/5 H

■ = Hart PVC ■ = Weich PVC | HH = Halbhart PVC □ = Andere Kunststoffe

20 | SONDERPROFILE

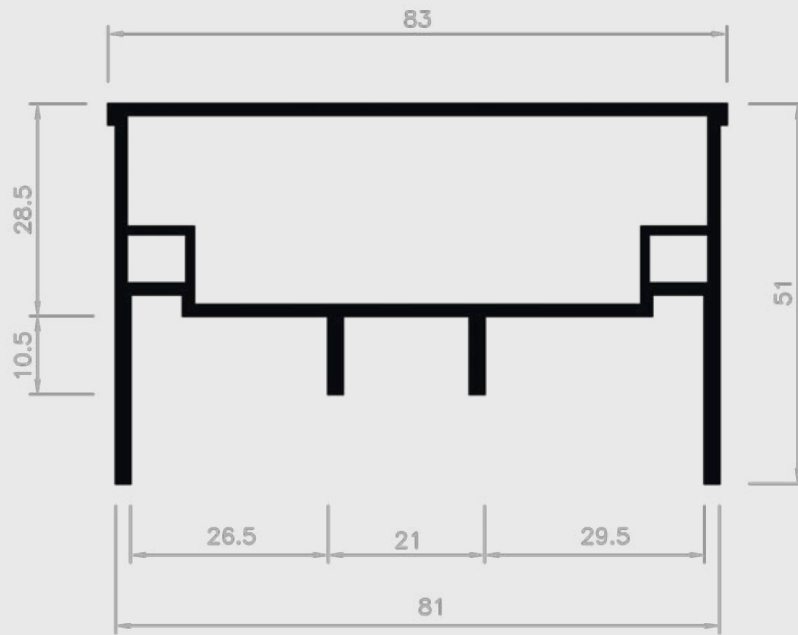

Nr. 43/7 H

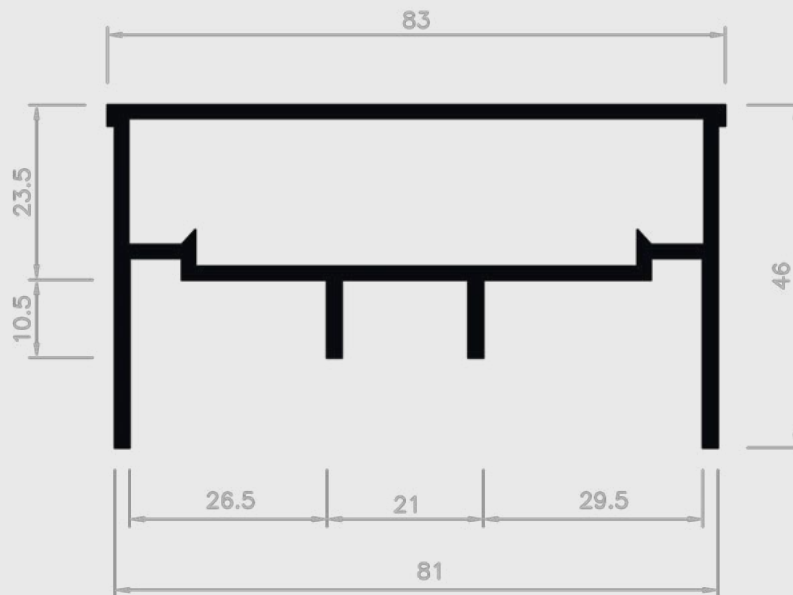

Nr. 43/6 H

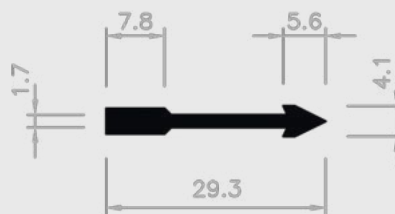

Nr. 43/8 H

= Hart PVC
 = Weich PVC | HH = Halbhart PVC
 = Andere Kunststoffe

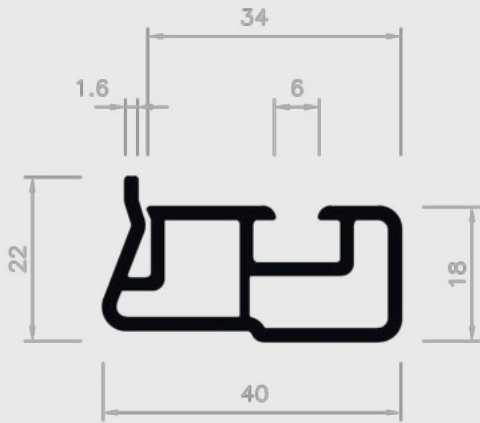

Nr. 42/1 H

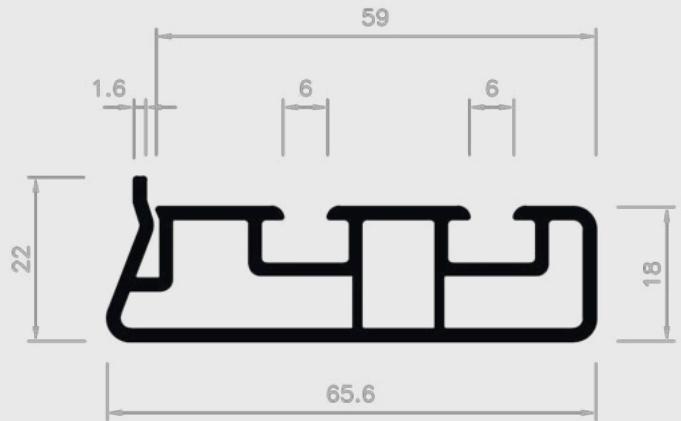

Nr. 42/2 H

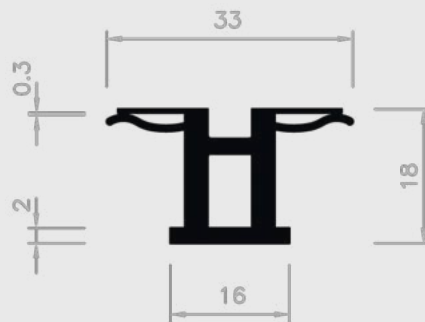

Nr. 42/7 H

= Hart PVC
 = Weich PVC | HH = Halbhart PVC
 = Andere Kunststoffe

20 | SONDERPROFILE

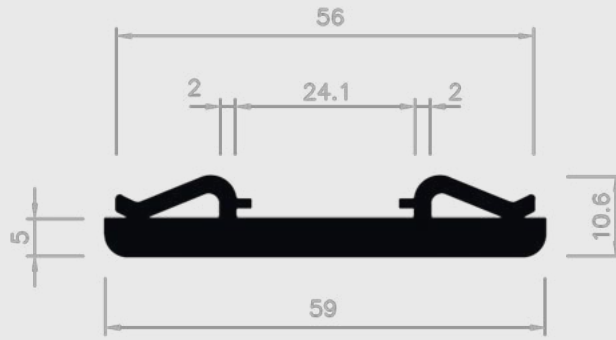

Nr. 42/8 H

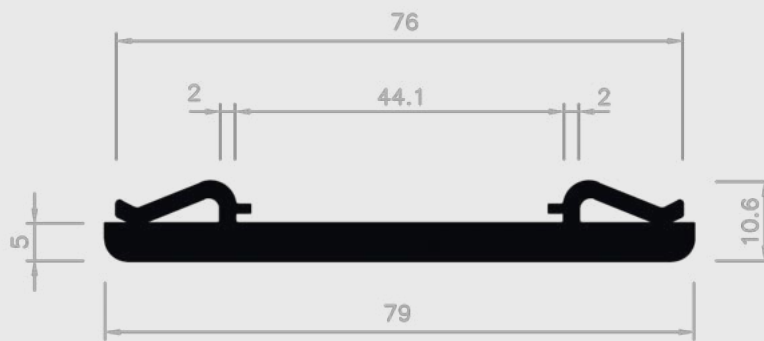

Nr. 42/9 H



Nr. 42/10 H

= Hart PVC
 = Weich PVC | HH = Halbhart PVC
 = Andere Kunststoffe

20 | SONDERPROFILE



Nr. 42/11 H



Nr. 42/12 H

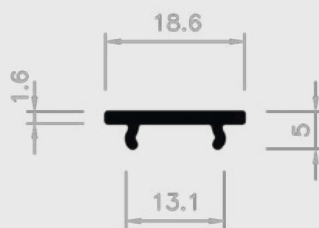

Nr. 42/13 H

= Hart PVC
 = Weich PVC | HH = Halbhart PVC
 = Andere Kunststoffe

20 | SONDERPROFILE

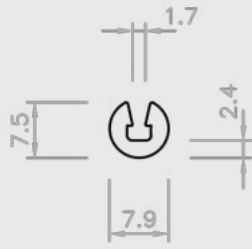

Nr. 54/34a PC

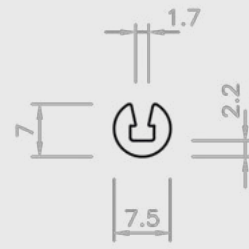

Nr. 54/34b PC

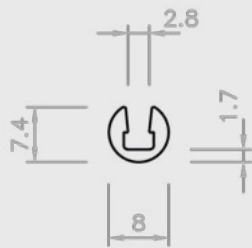

Nr. 54/40 PC

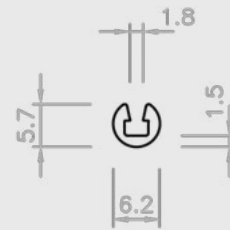

Nr. 54/50 PC

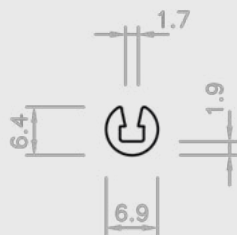

Nr. 54/51 PC

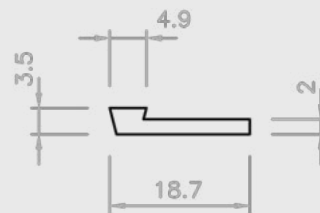

Nr. 54/41 NORYL

= Hart PVC
 = Weich PVC | HH = Halbhart PVC
 = Andere Kunststoffe

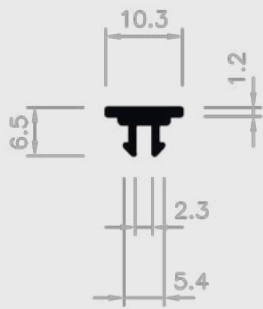

Nr. 33/22 H

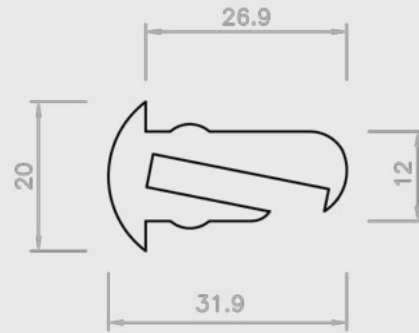

Nr. 32/5 PC

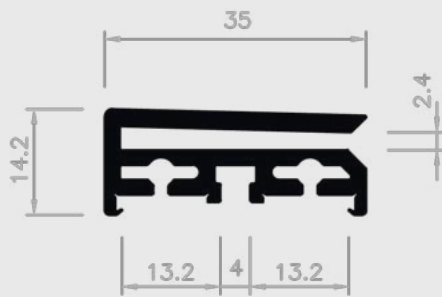

Nr. 33/21 H

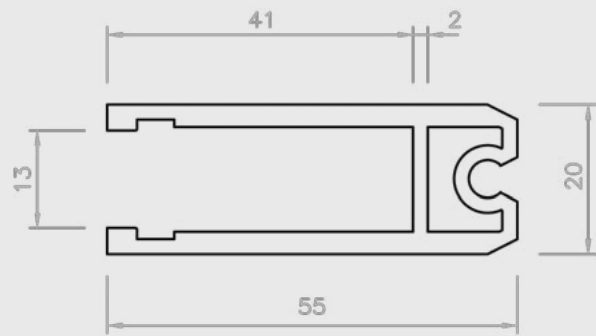

Nr. 32/6 ABS

= Hart PVC
 = Weich PVC | HH = Halbhart PVC
 = Andere Kunststoffe

20 | SONDERPROFILE

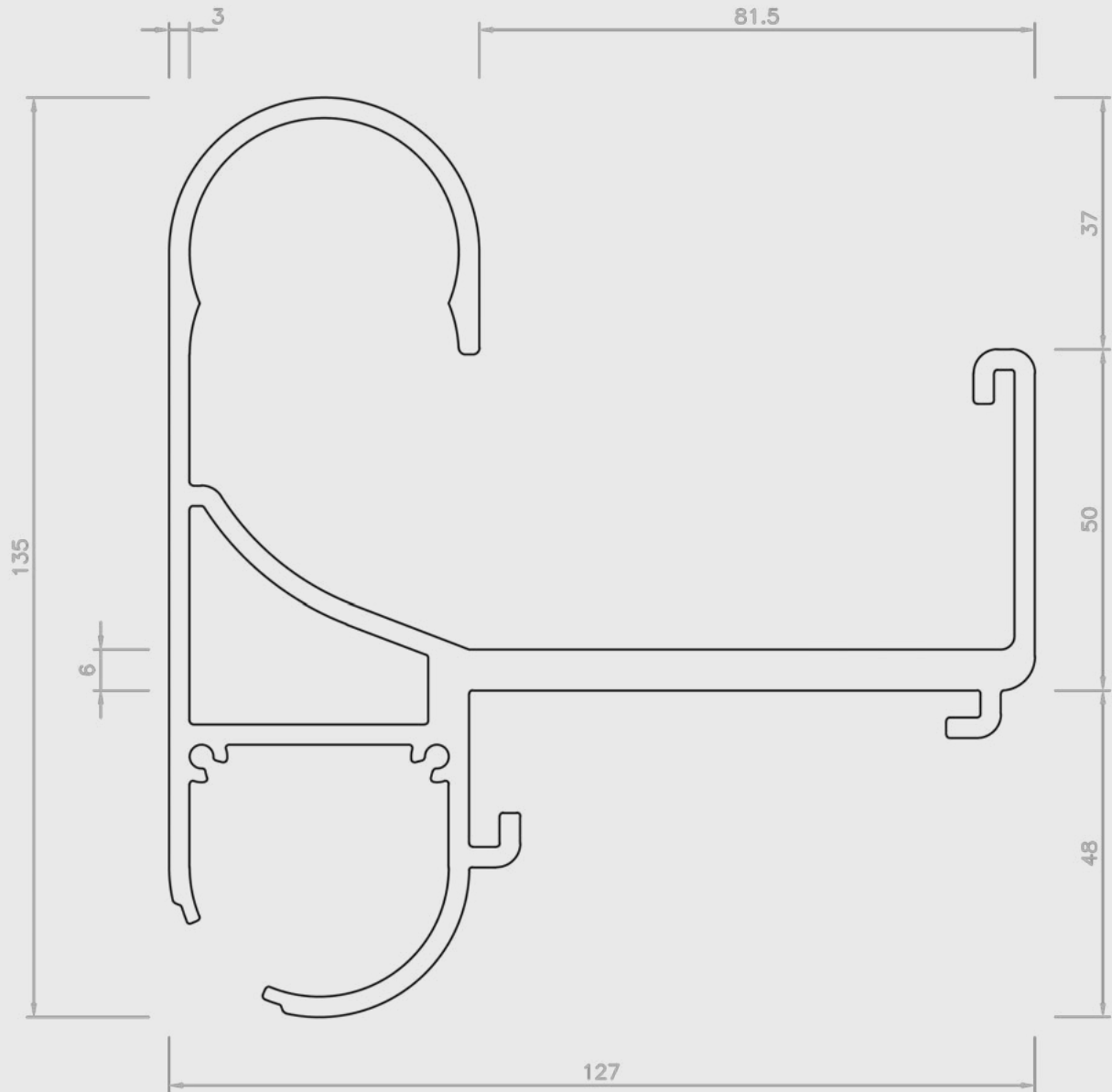

Nr. 52/2 PPE-PS

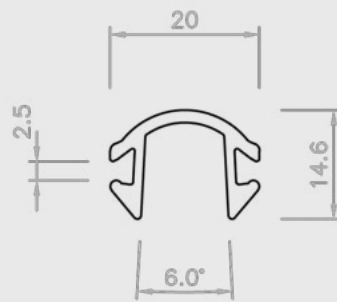

Nr. 52/3 ABS

= Hart PVC
 = Weich PVC | HH = Halbhart PVC
 = Andere Kunststoffe

20 | SONDERPROFILE

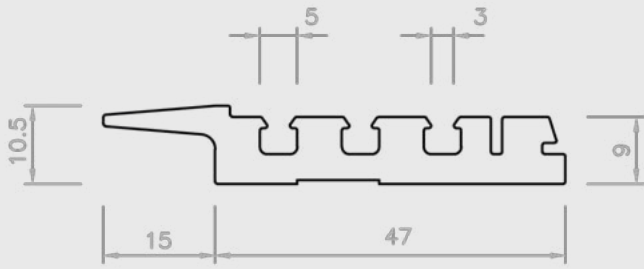

Nr. 64/10 WPC

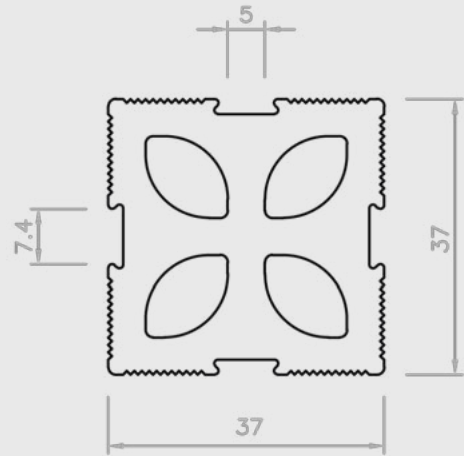

Nr. 64/9 WPC

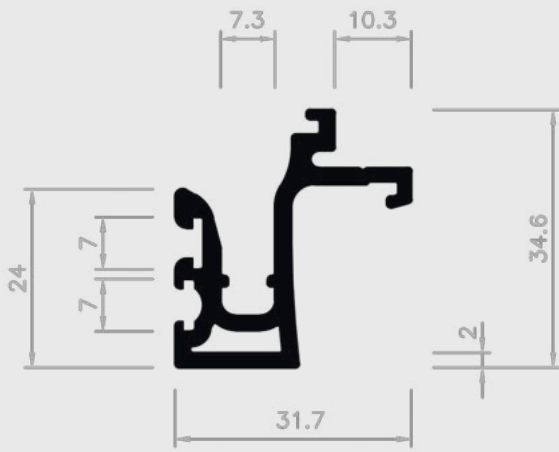

Nr. 23/60 H

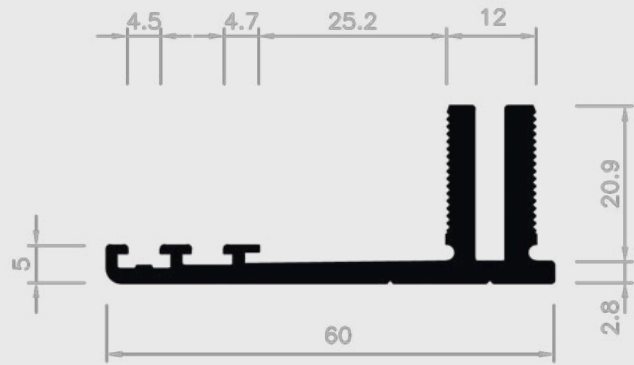

Nr. 17/74 H

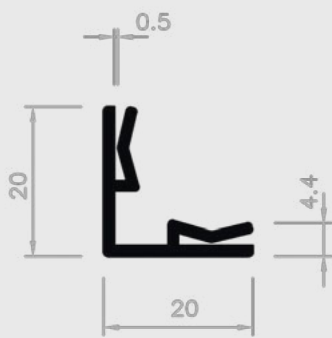

Nr. 17/64 H

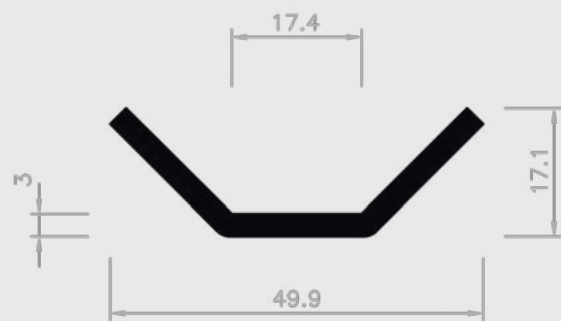

Nr. 20/49 H

= Hart PVC
 = Weich PVC | HH = Halbhart PVC
 = Andere Kunststoffe

20 | SONDERPROFILE

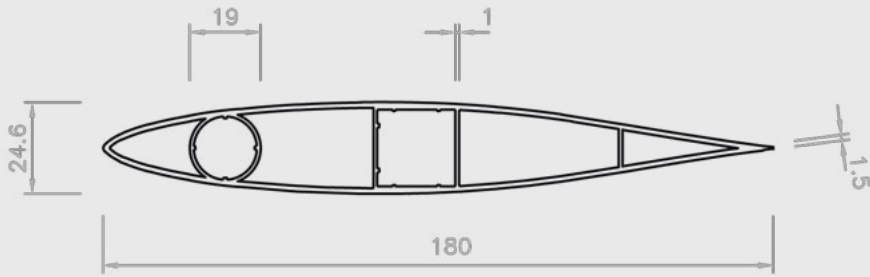

Nr. 32/22 ABS

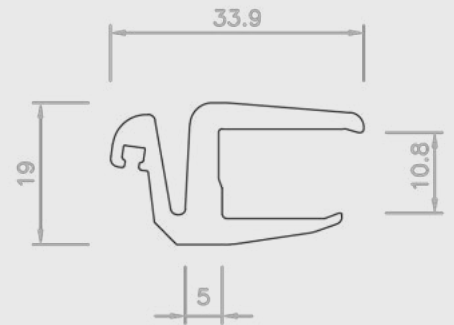

Nr. 32/3 PC

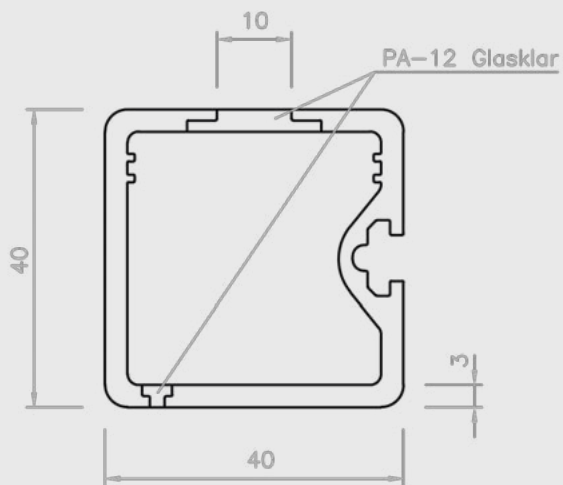

Nr. 40/40 PA-12

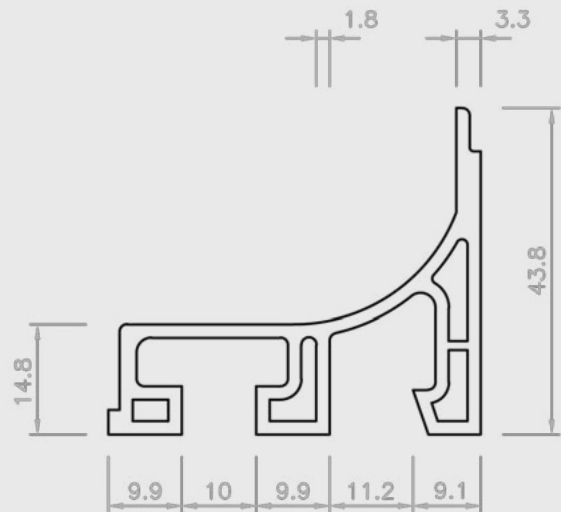

Nr. 50/44 PC-ASA

= Hart PVC
 = Weich PVC | HH = Halbhart PVC
 = Andere Kunststoffe



Nr. 27/45 H

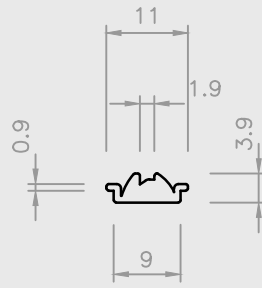

Nr. 33/03 PMMA



Nr. 50/2 W

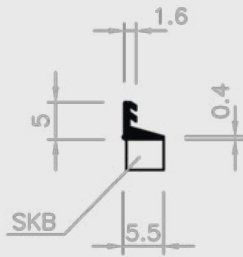

Nr. 5/22a H

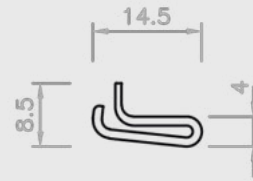

Nr. 3/37 PA

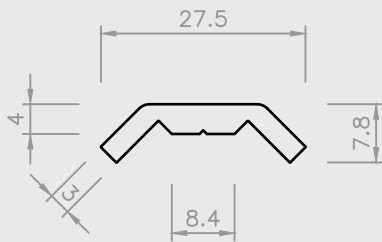

Nr. 20/50 PC+ABS

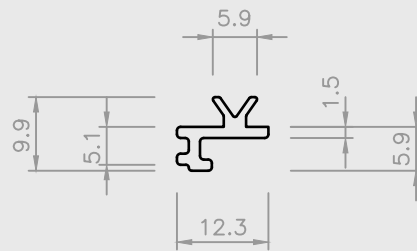

Nr. 33/28 HDPE

= Hart PVC
 = Weich PVC | HH = Halbhart PVC
 = Andere Kunststoffe

20 | SONDERPROFILE

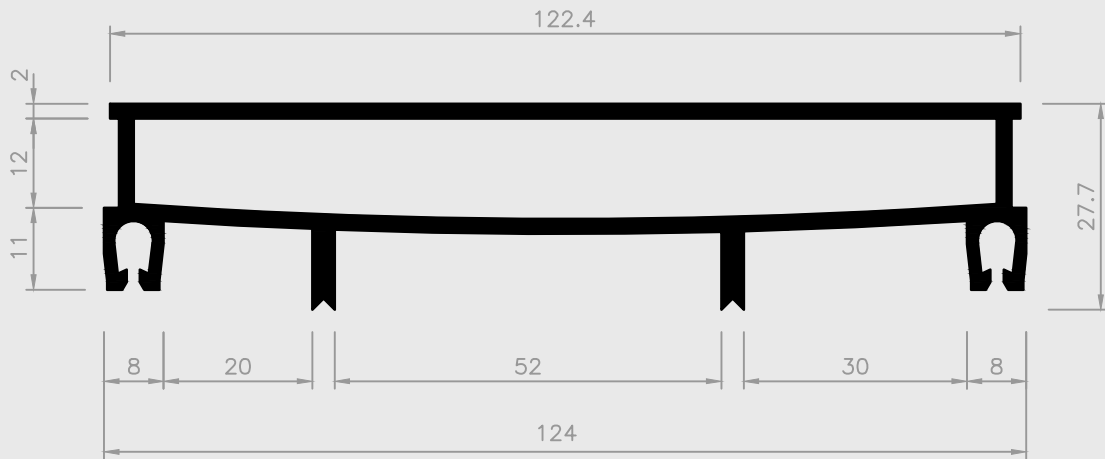

Nr. 43/09 H

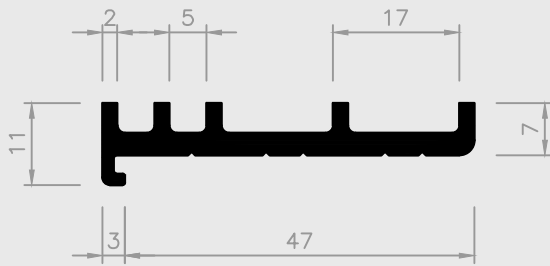

Nr. 31/16 H

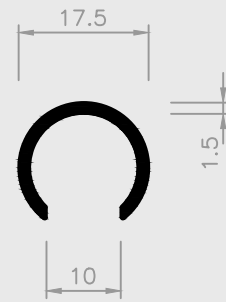

Nr. 43/10 H

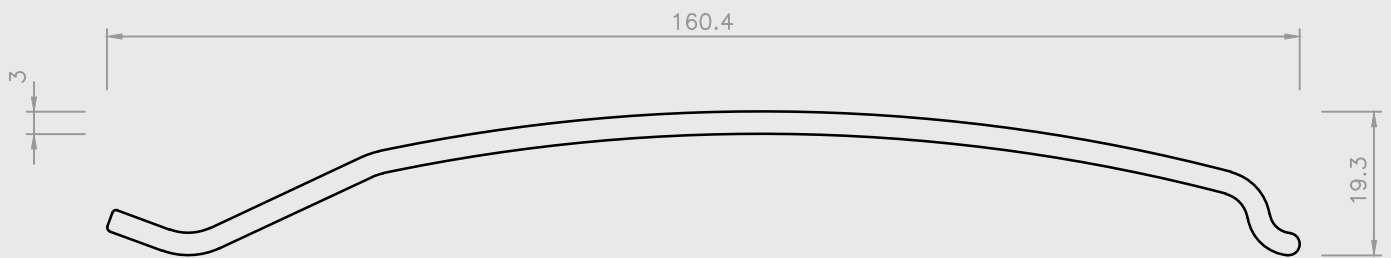

Nr. 27/27 PMMA

= Hart PVC
 = Weich PVC | HH = Halbhart PVC
 = Andere Kunststoffe

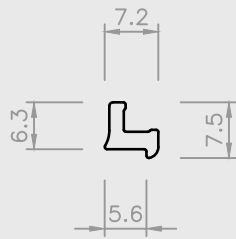

Nr. 5/25 PC+ASA

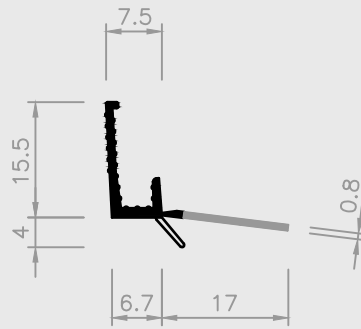

Nr. 26/61 H+W+TPE

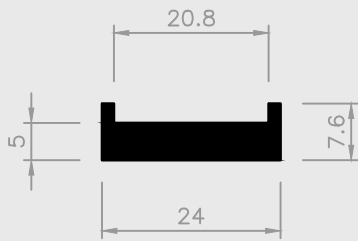

Nr. 20/46 H

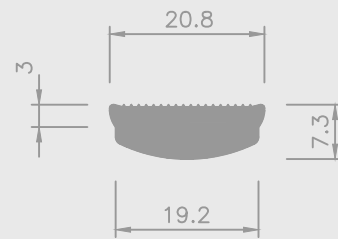

Nr. 66/81 HH



Nr. 42/14 H

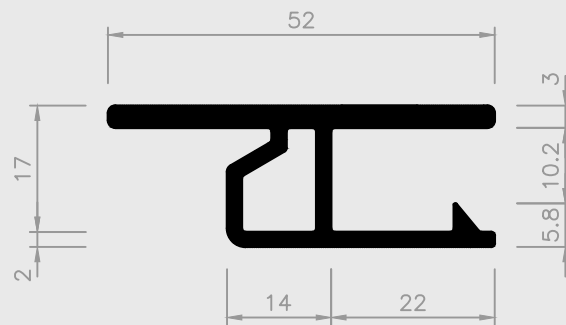

Nr. 17/77 H

= Hart PVC
 = Weich PVC | HH = Halhart PVC
 = Andere Kunststoffe

20 | SONDERPROFILE

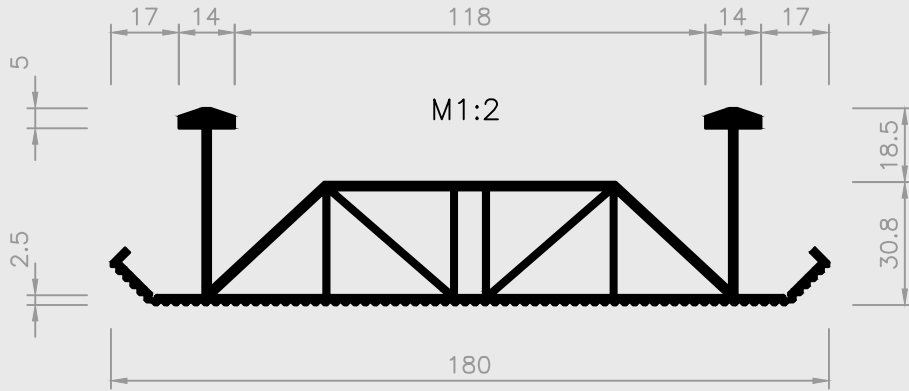

Nr. 61/10 H

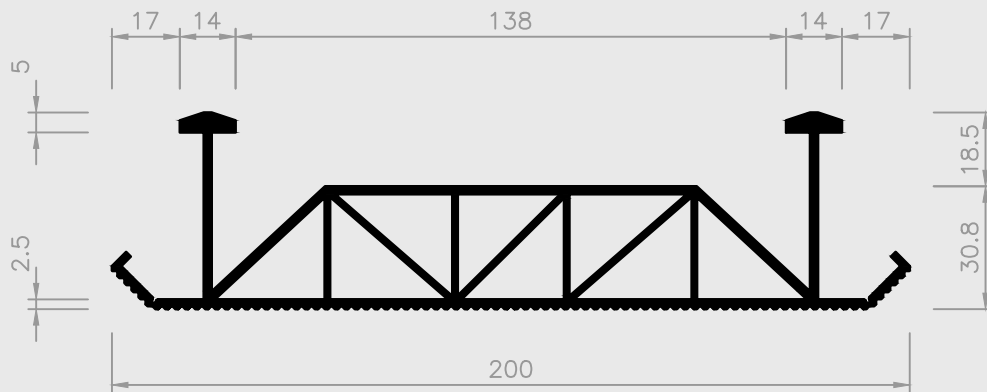

Nr. 61/11 H

■ = Hart PVC ■ = Weich PVC | HH = Halbhart PVC □ = Andere Kunststoffe

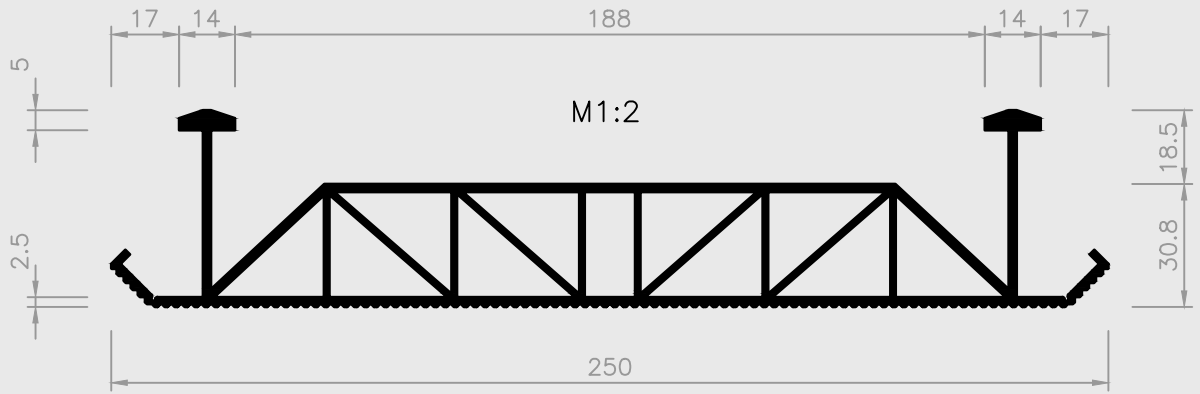

Nr. 61/12 H

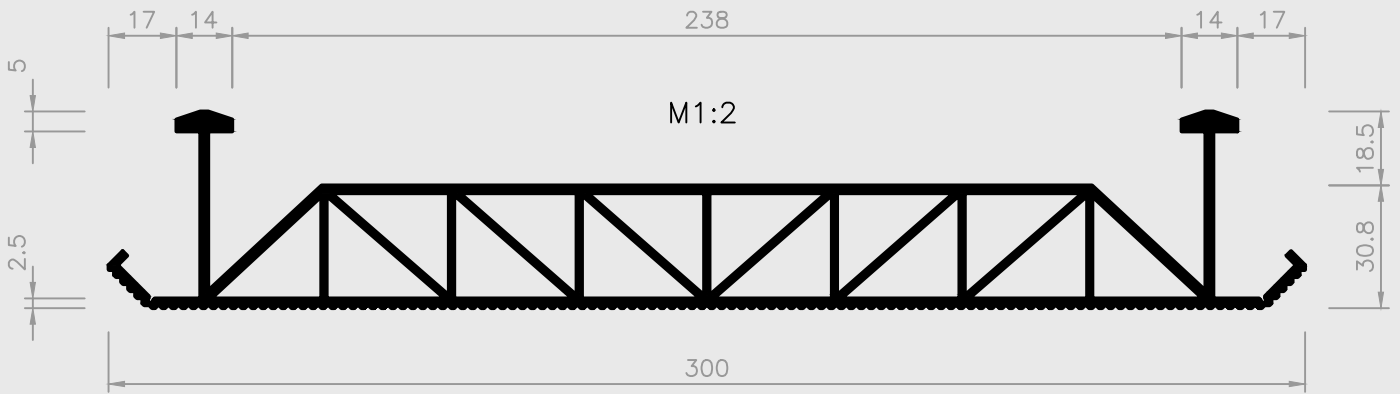

Nr. 61/13 H

= Hart PVC
 = Weich PVC | HH = Halbhart PVC
 = Andere Kunststoffe

20 | SONDERPROFILE

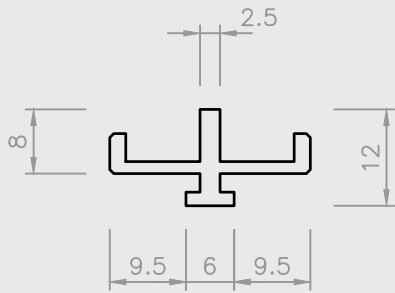

Nr. 52/23 PC-ASA

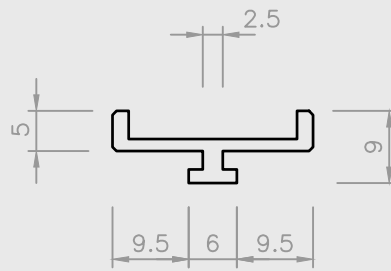

Nr. 52/24 PC-ASA

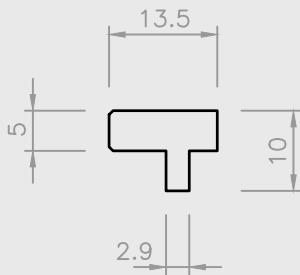

Nr. 52/25 PC-ASA

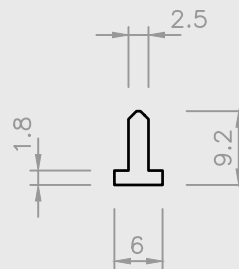

Nr. 52/26 PC-ASA

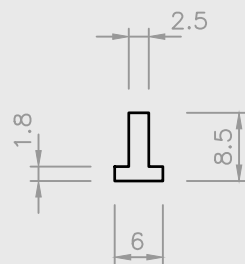

Nr. 52/27 PC-ASA

= Hart PVC
 = Weich PVC | HH = Halbhart PVC
 = Andere Kunststoffe

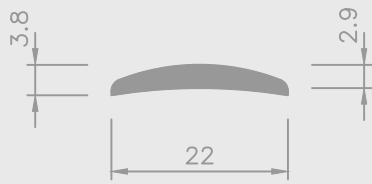

Nr. 10/01A W

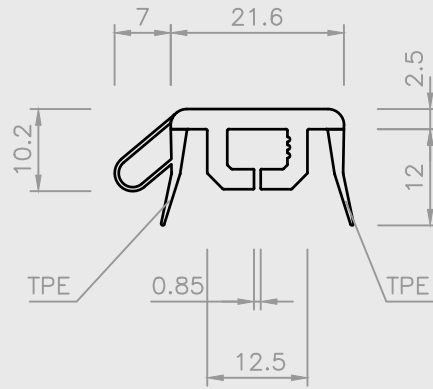

Nr. 17/78 ABS+TPE

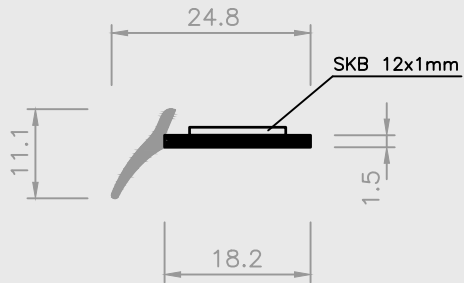

Nr. 22/55A H+W

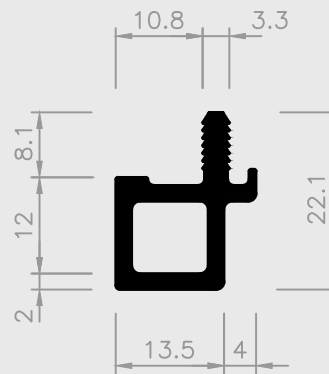

Nr. 23/08 H

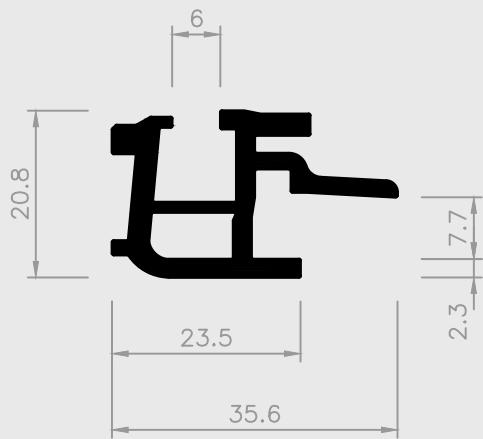

Nr. 24/92 H

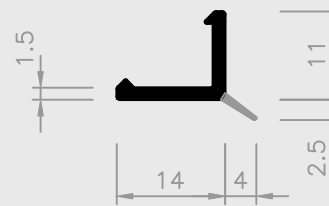

Nr. 26/22 H+W

■ = Hart PVC ■ = Weich PVC | HH = Halbhart PVC □ = Andere Kunststoffe

20 | SONDERPROFILE

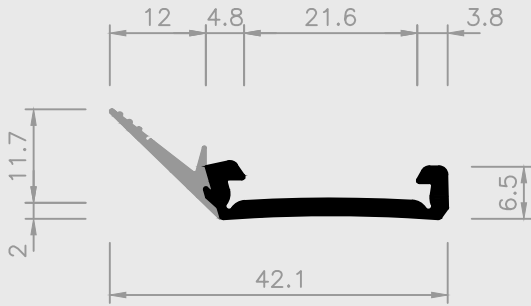

Nr. 27/50 H+W

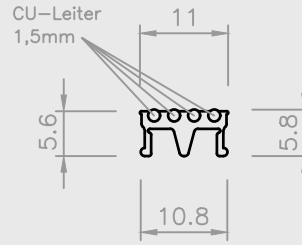

Nr. 34/10 PC-ABS

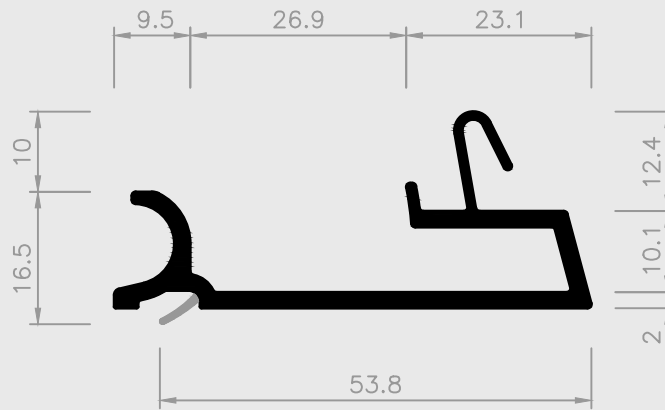

Nr. 36/01 H+W

= Hart PVC
 = Weich PVC | HH = Halbhart PVC
 = Andere Kunststoffe

20 | SONDERPROFILE

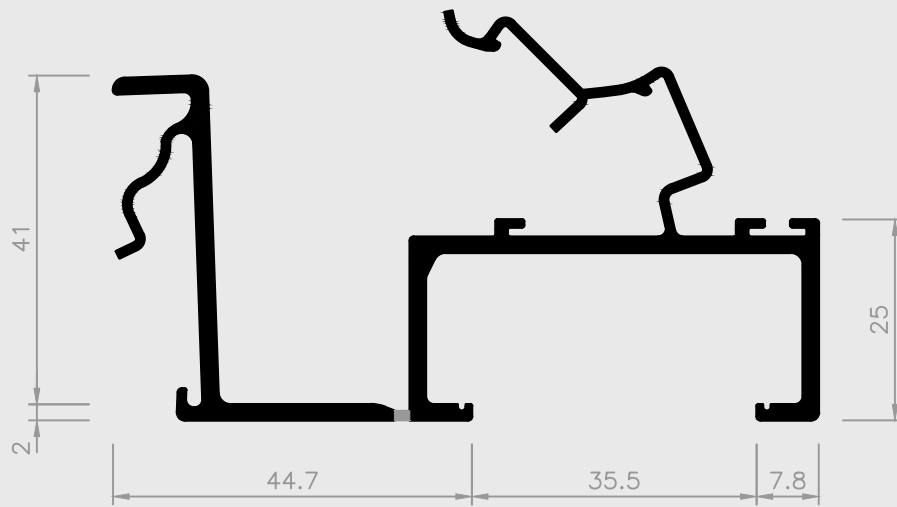

Nr. 34/04 H+W

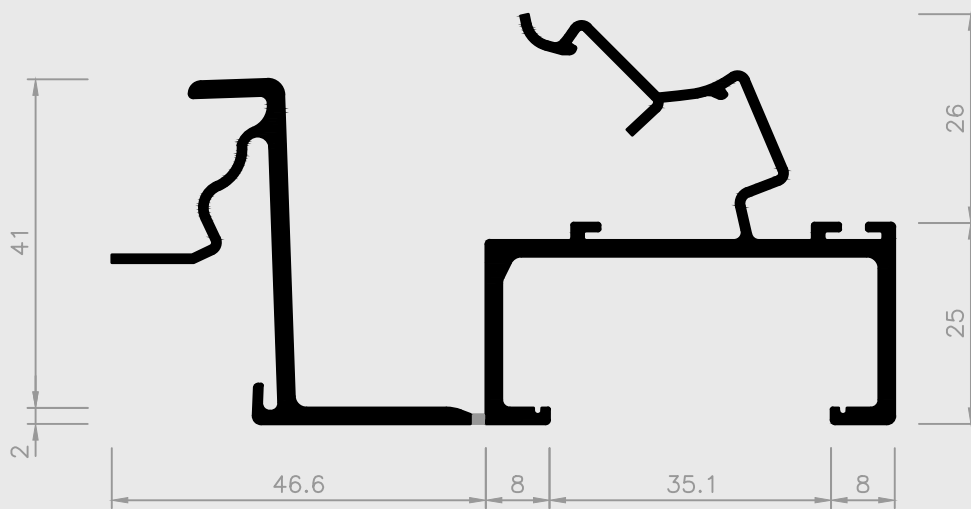

Nr. 34/05 H+W

■ = Hart PVC ■ = Weich PVC | HH = Halbhart PVC □ = Andere Kunststoffe

20 | SONDERPROFILE

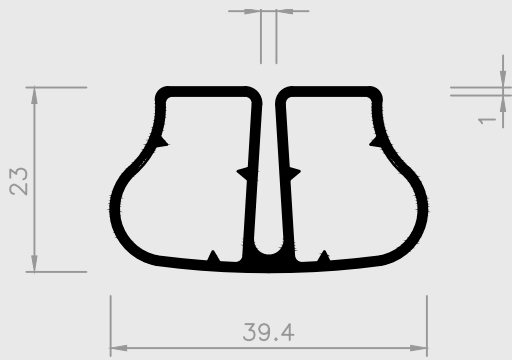

Nr. 06/60 H

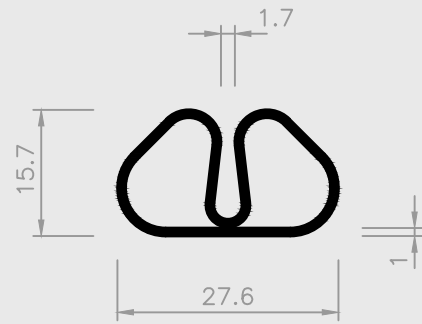

Nr. 06/61 H

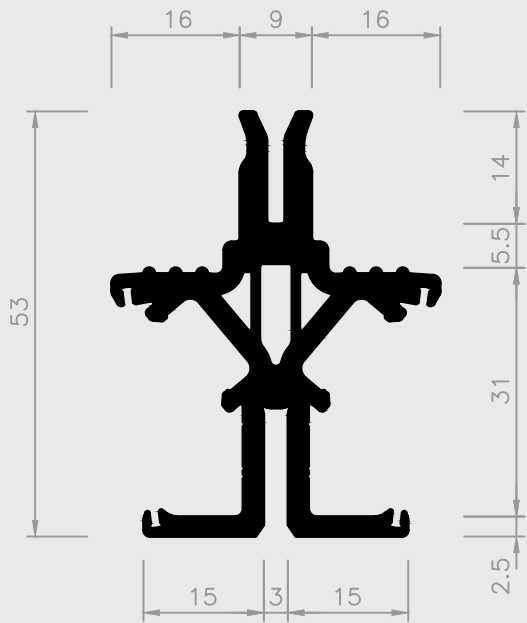

Nr. 27/51 H

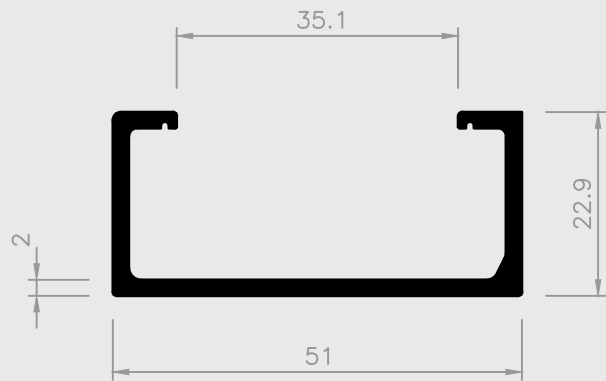

Nr. 34/06 H

■ = Hart PVC

■ = Weich PVC | HH = Halbhart PVC

□ = Andere Kunststoffe

20 | SONDERPROFILE



Nr. 35/44 H

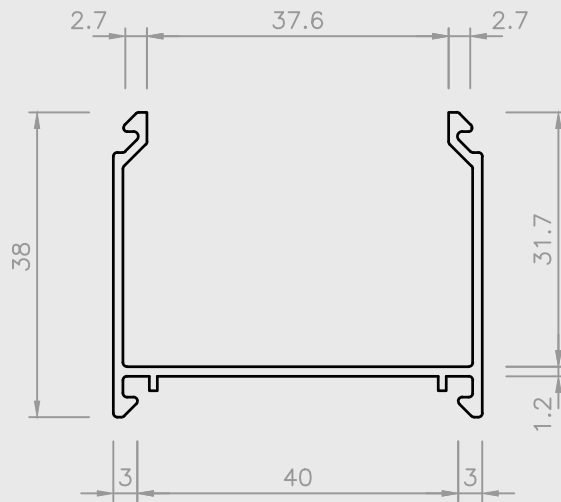

Nr. 35/45 H

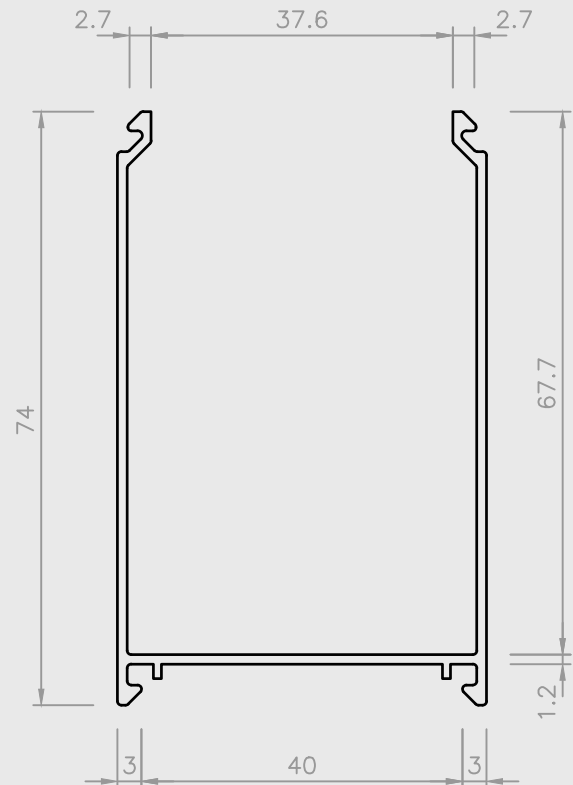

Nr. 35/43 PC-ABS

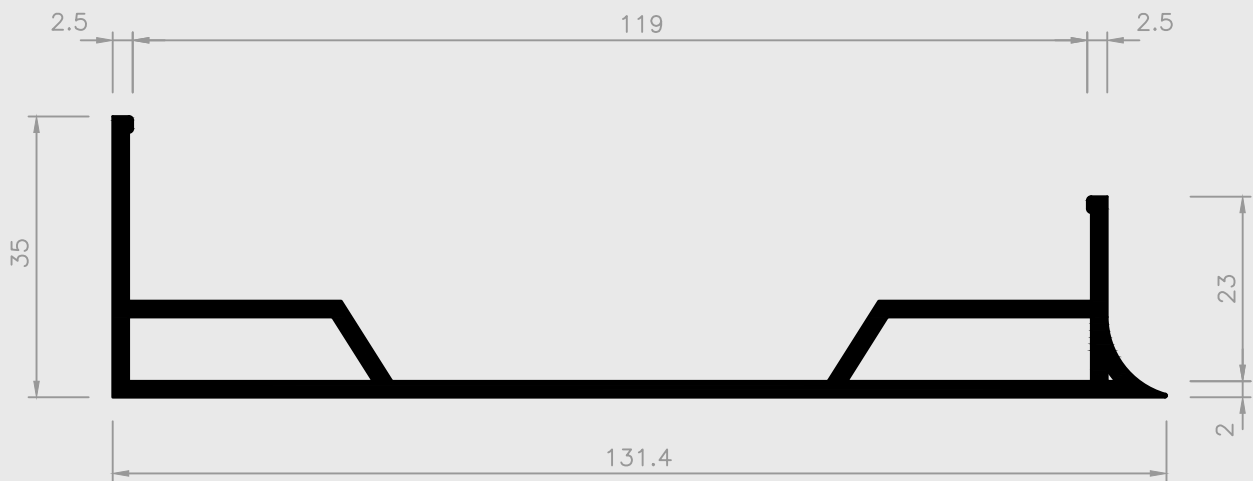

Nr. 42/26 H

■ = Hart PVC

■ = Weich PVC | HH = Halbhart PVC

□ = Andere Kunststoffe

20 | SONDERPROFILE



Nr. 42/27 H



Nr. 60/66 H

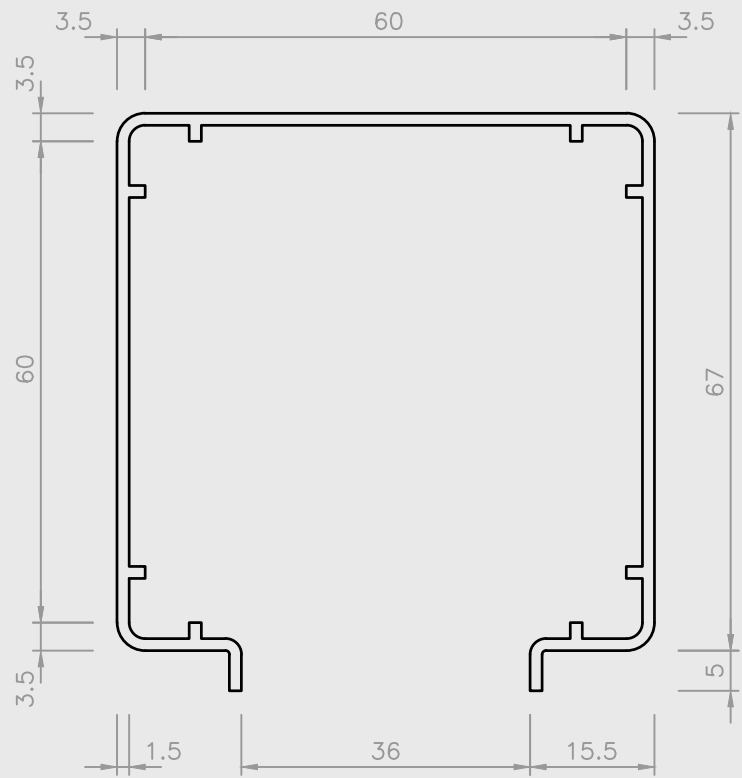

Nr. 60/64 PET

■ = Hart PVC

■ = Weich PVC | HH = Halbhart PVC

□ = Andere Kunststoffe

20 | SONDERPROFILE

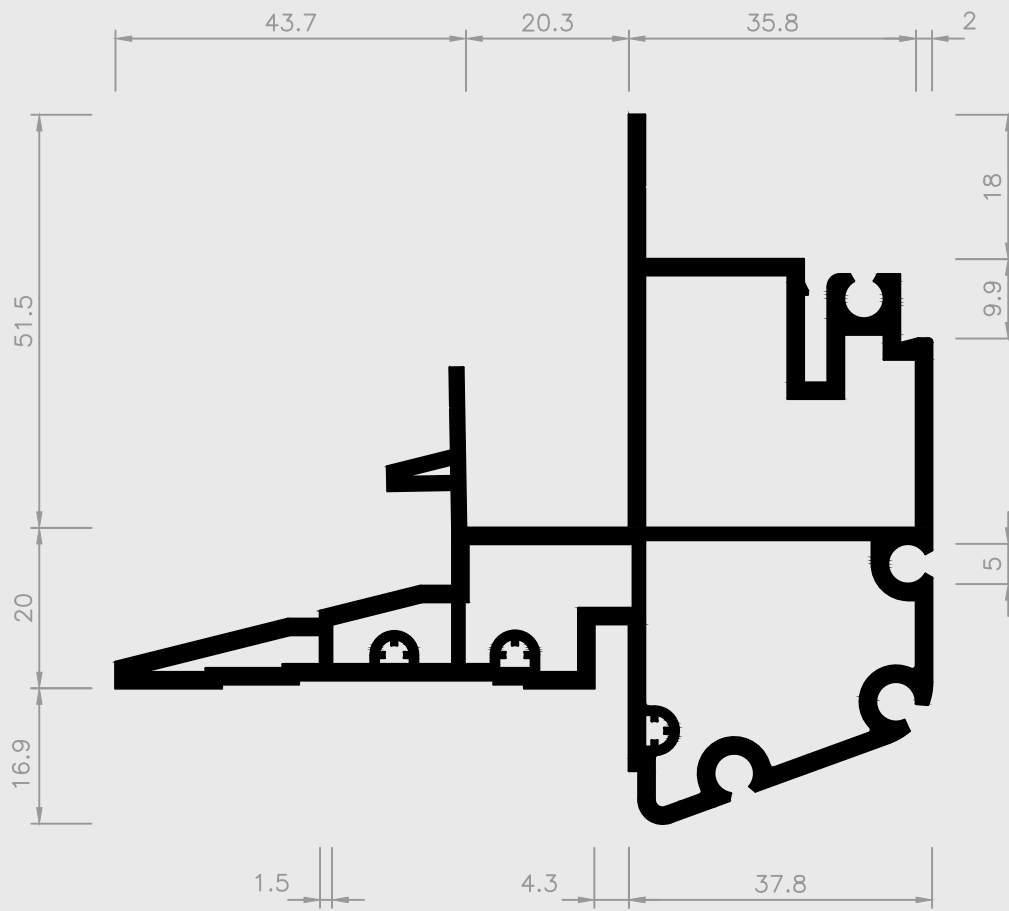

Nr. 08/66 H

■ = Hart PVC ■ = Weich PVC | HH = Halbhart PVC □ = Andere Kunststoffe



ZITTA
austria
plastic profiles

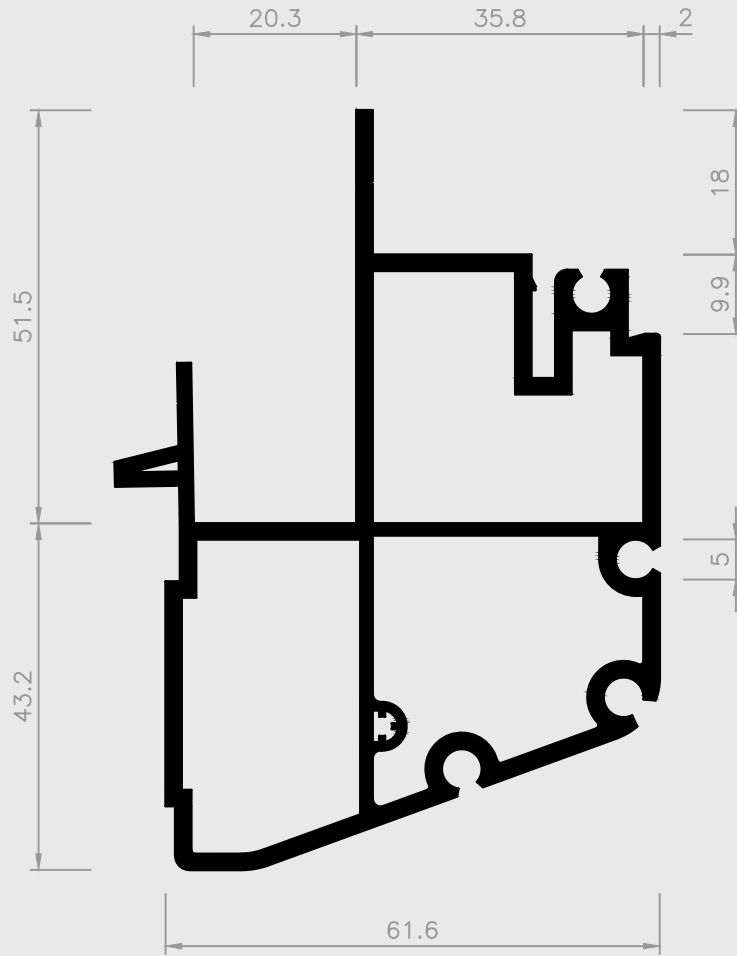

Nr. 08/68 H

■ = Hart PVC

■ = Weich PVC | HH = Halbhart PVC

□ = Andere Kunststoffe

20 | SONDERPROFILE

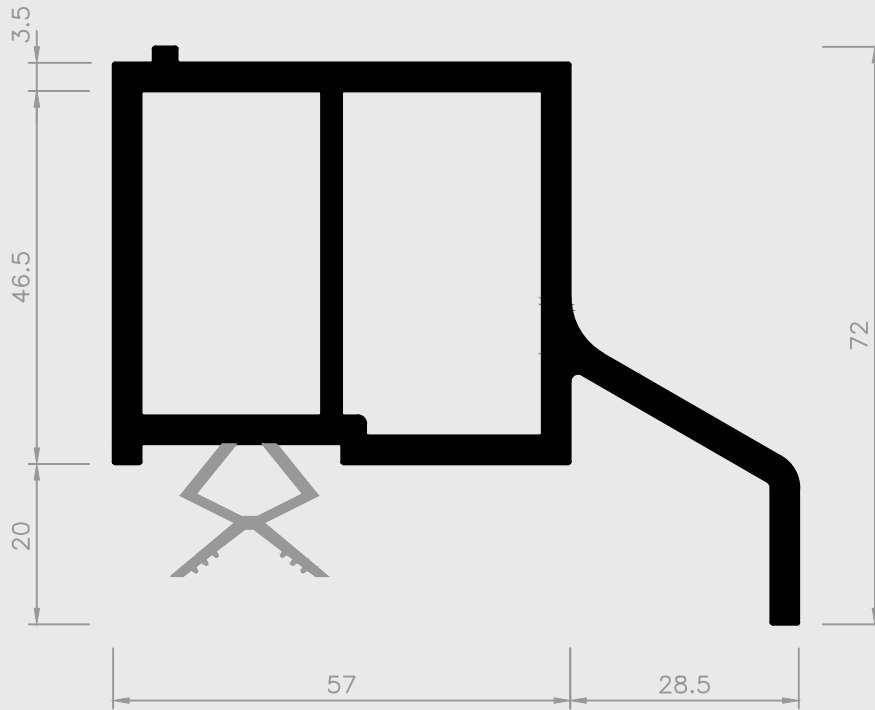

Nr. 29/46 H+W

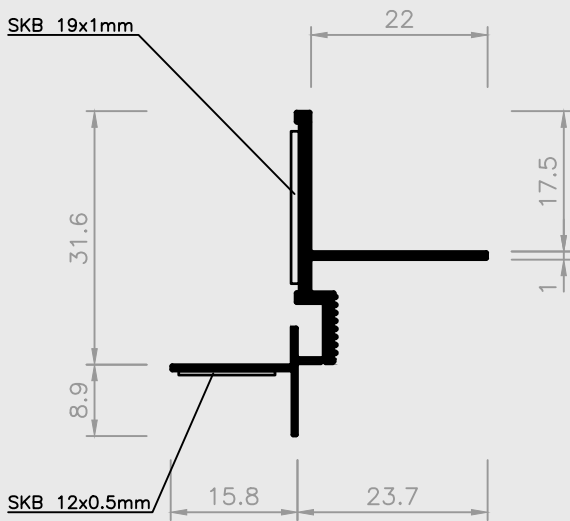

Nr. 32/28 H

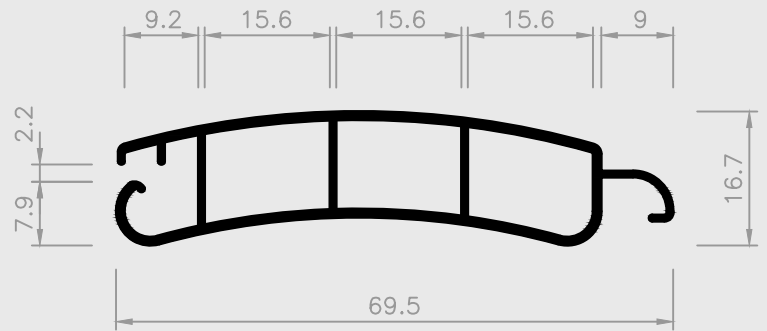

Nr. 06/91 H

= Hart PVC
 = Weich PVC | HH = Halbhart PVC
 = Andere Kunststoffe

20 | SONDERPROFILE

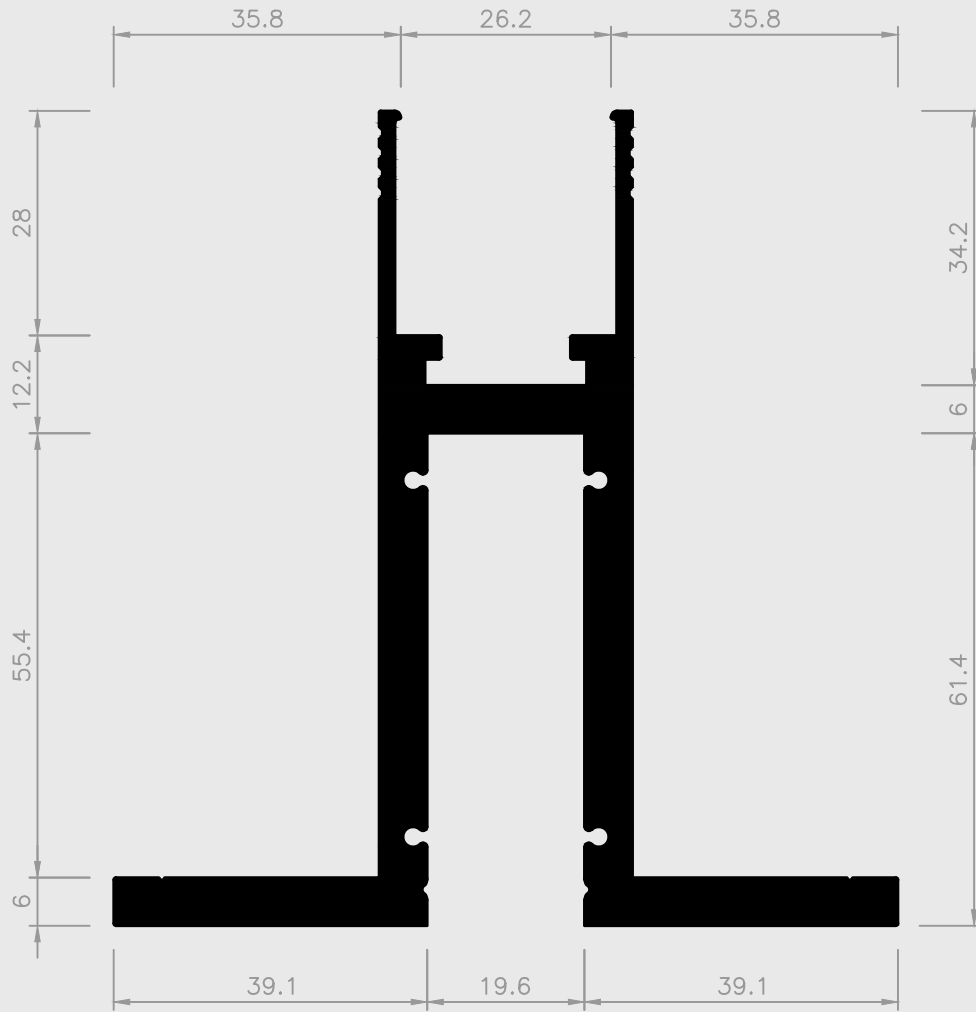

Nr. 32/07 H

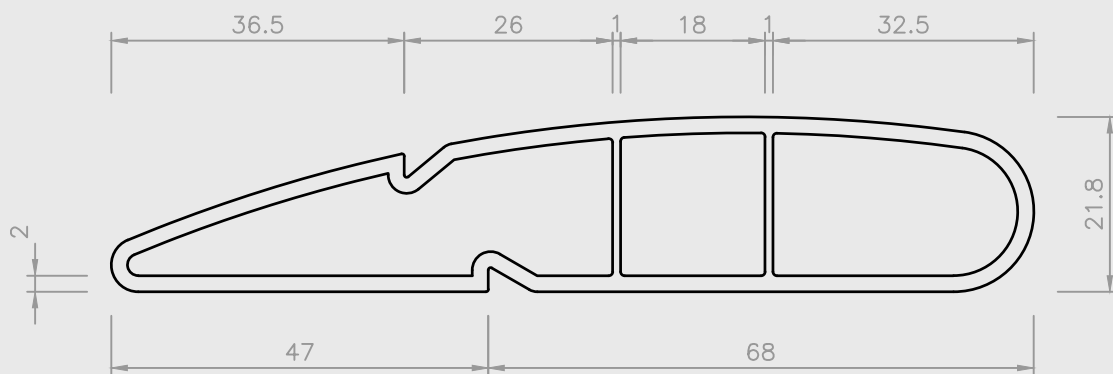

Nr. 32/27 PP

= Hart PVC
 = Weich PVC | HH = Halbhart PVC
 = Andere Kunststoffe

20 | SONDERPROFILE

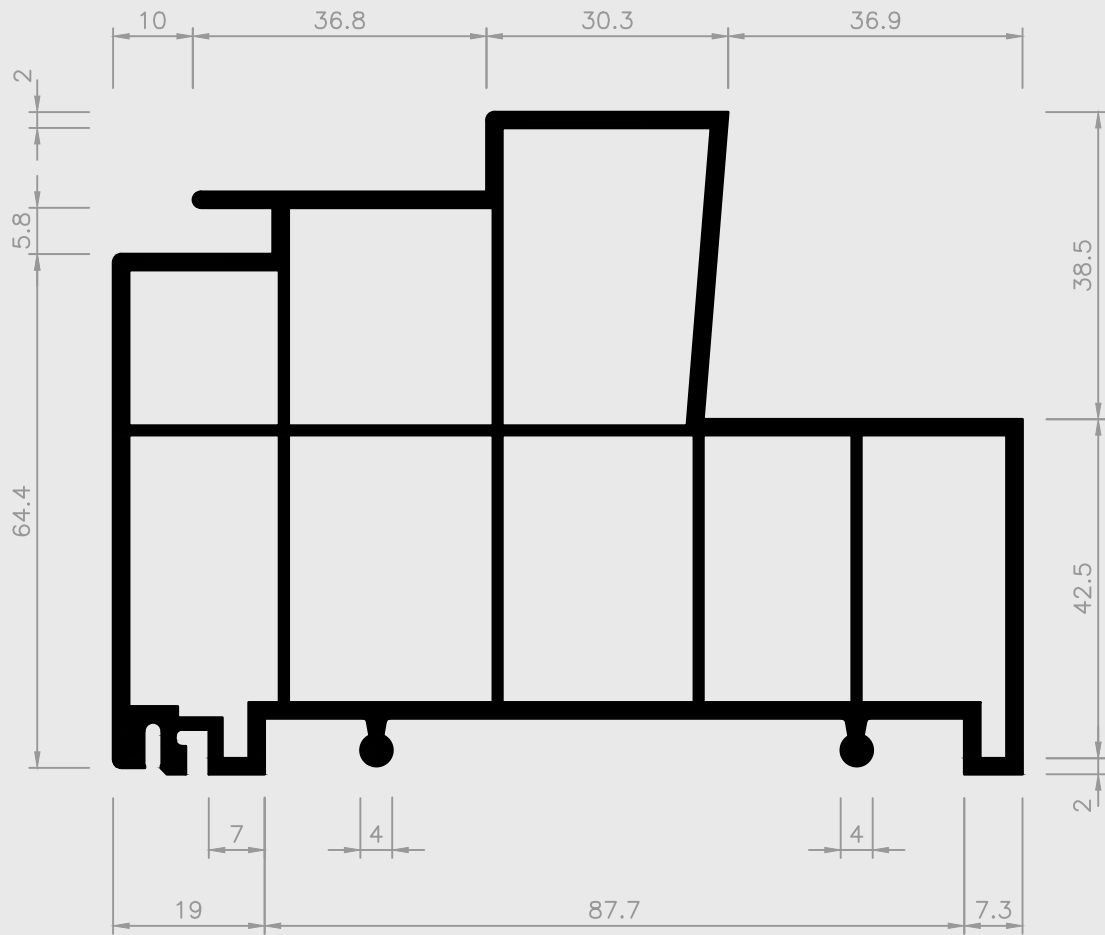

Nr. 8/62 H

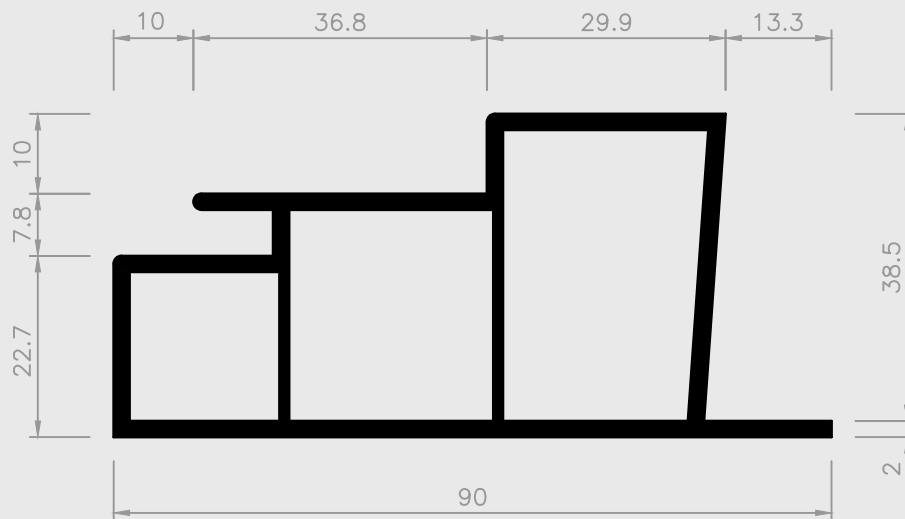

Nr. 8/65 H

= Hart PVC
 = Weich PVC | HH = Halbhart PVC
 = Andere Kunststoffe

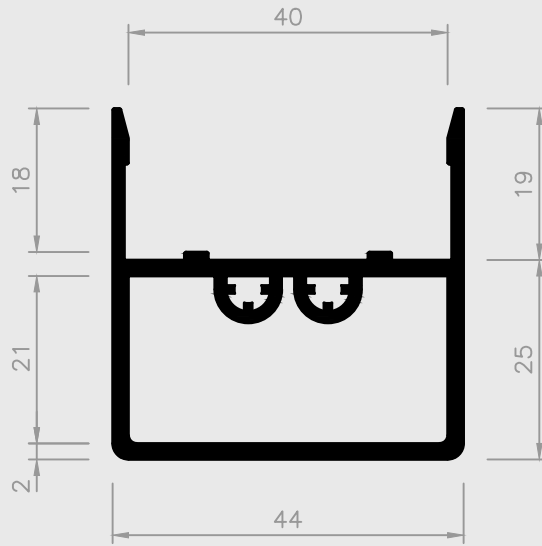

Nr. 8/58 H

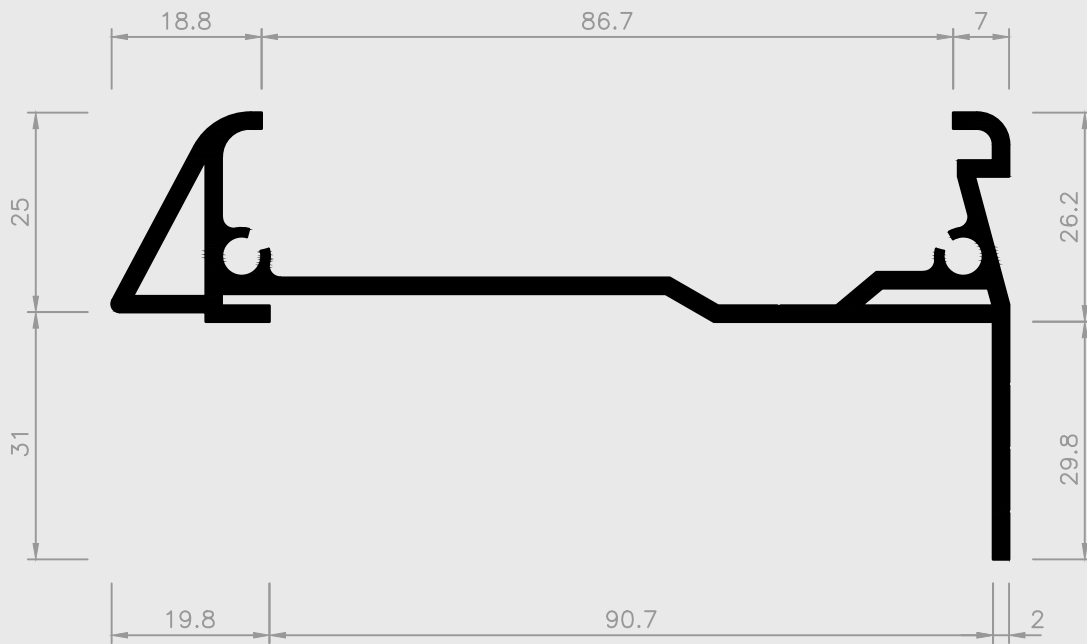

Nr. 8/59 H

= Hart PVC
 = Weich PVC | HH = Halbhart PVC
 = Andere Kunststoffe

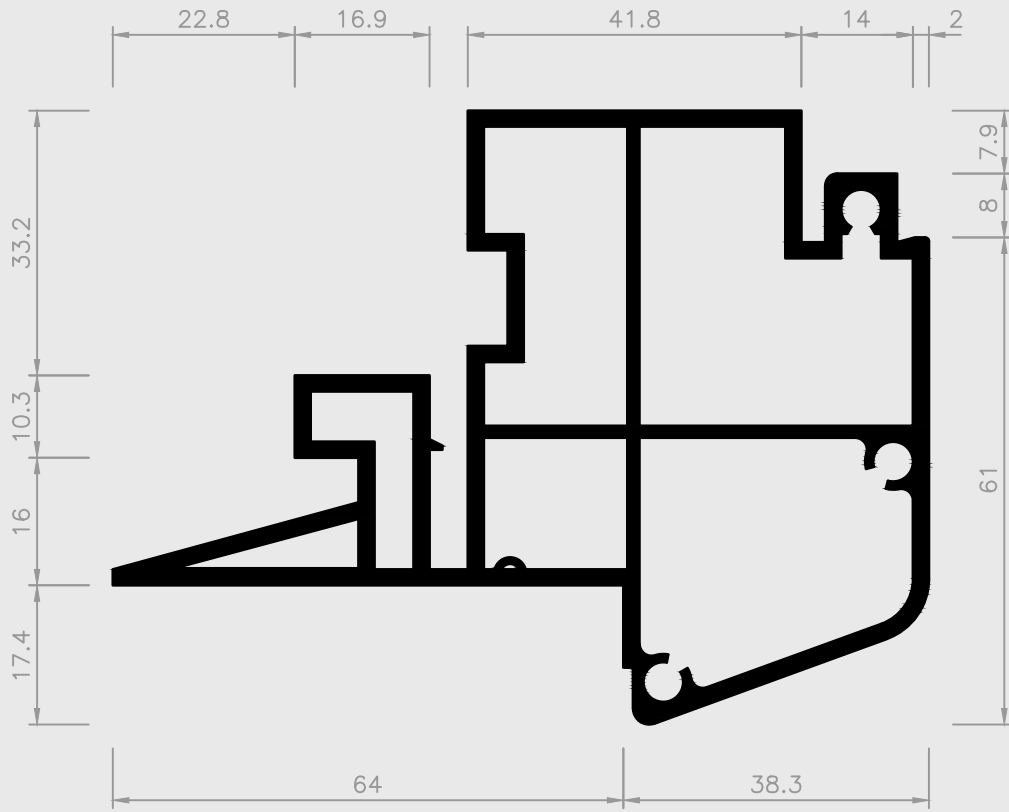

Nr. 8/60 H

= Hart PVC
 = Weich PVC | HH = Halbhart PVC
 = Andere Kunststoffe

20 | SONDERPROFILE

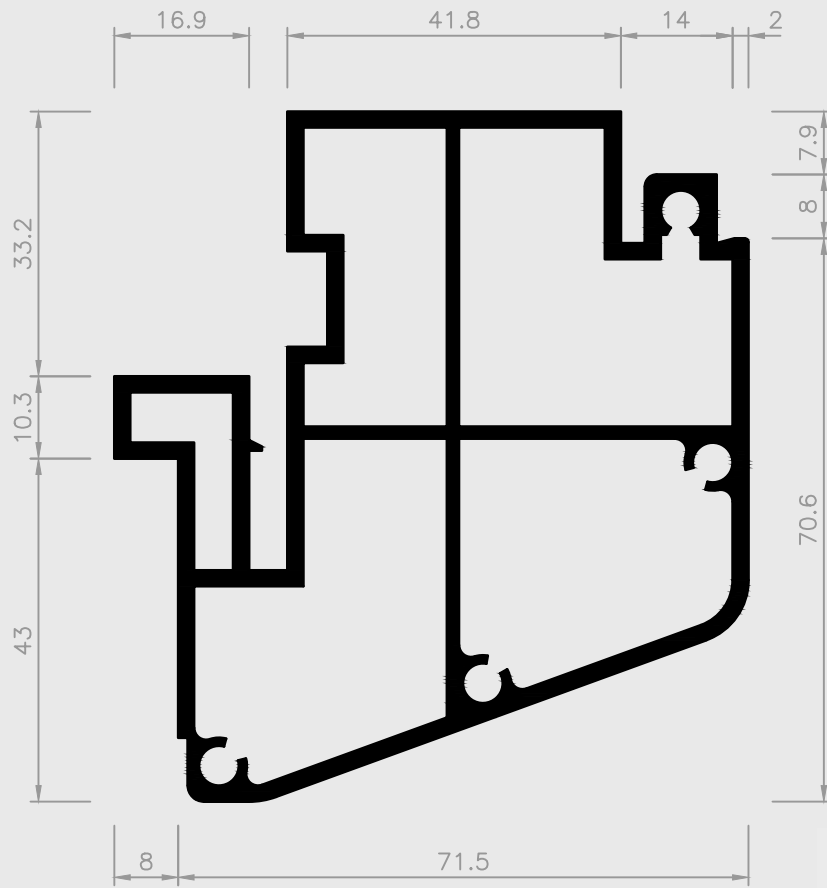

Nr. 8/61 H

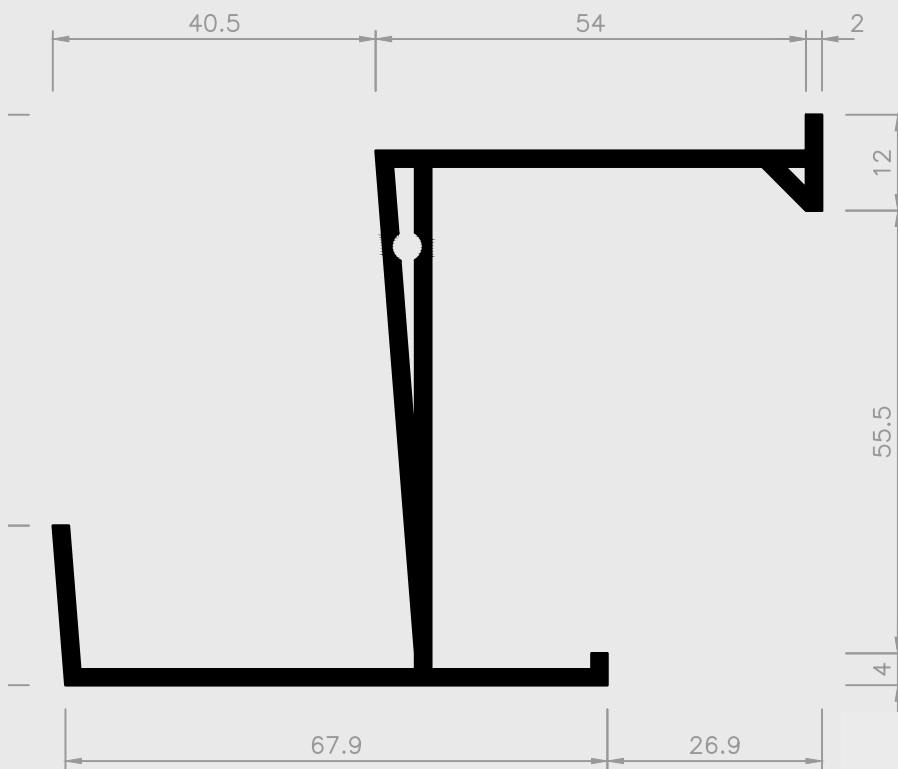

Nr. 8/64 H

= Hart PVC
 = Weich PVC | HH = Halhart PVC
 = Andere Kunststoffe

20 | SONDERPROFILE

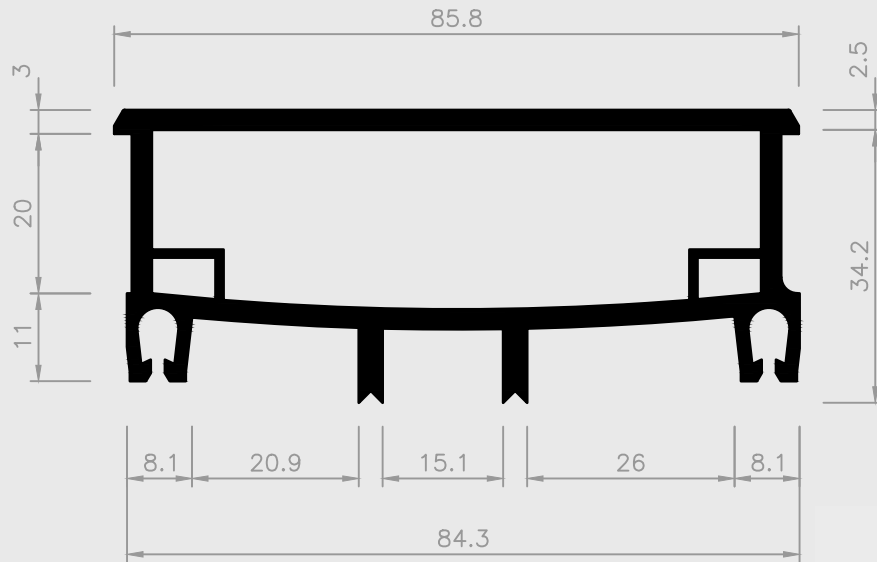

Nr. 43/04 H

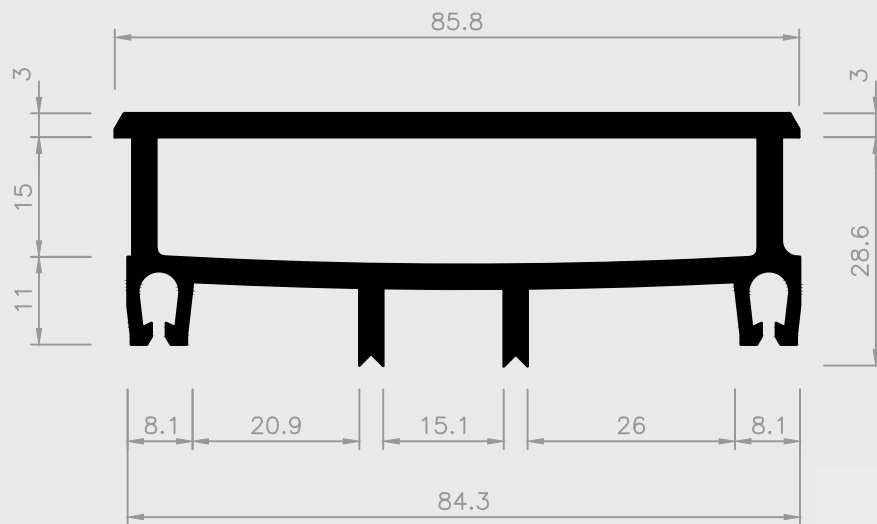

Nr. 43/05 H

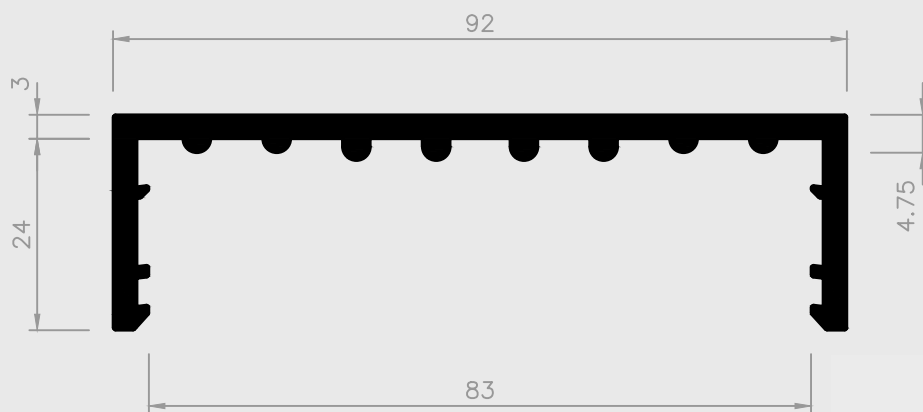

Nr. 43/11 H

= Hart PVC
 = Weich PVC | HH = Halbhart PVC
 = Andere Kunststoffe

20 | SONDERPROFILE

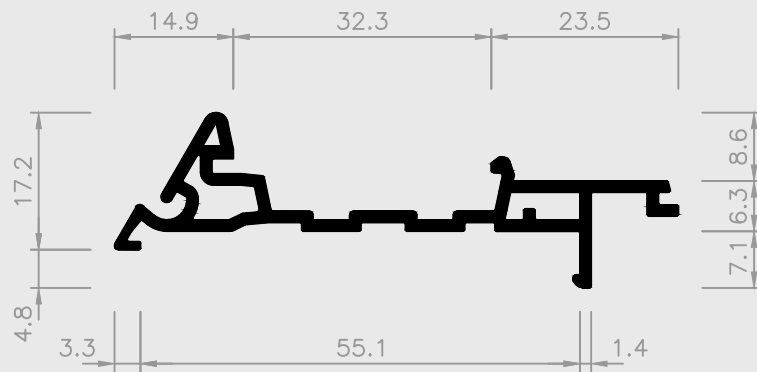

Nr. 34/01 H

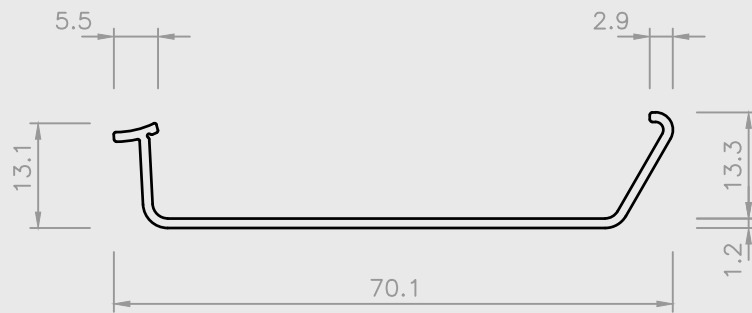

Nr. 34/02 PC

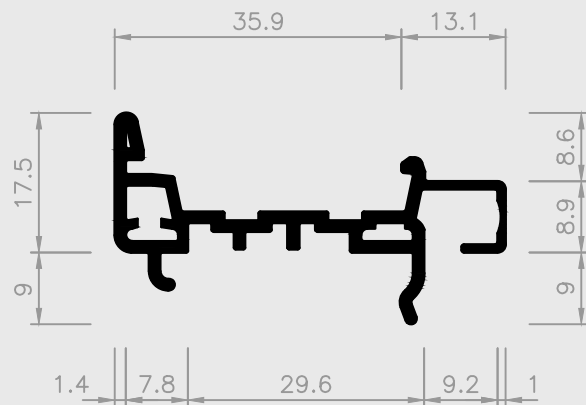

Nr. 34/03 H

= Hart PVC
 = Weich PVC | HH = Halbhart PVC
 = Andere Kunststoffe

20 | SONDERPROFILE

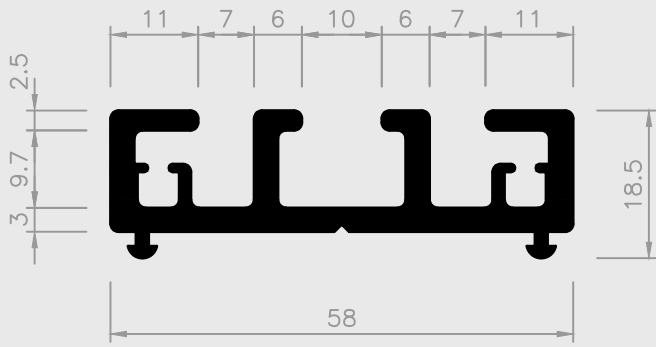

Nr. 23/49 H

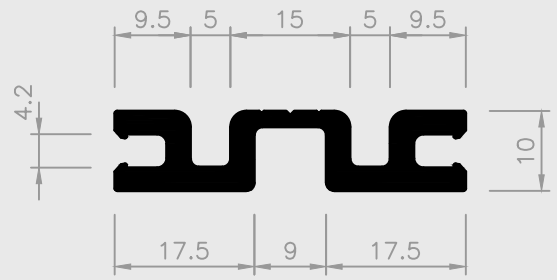

Nr. 23/50 H

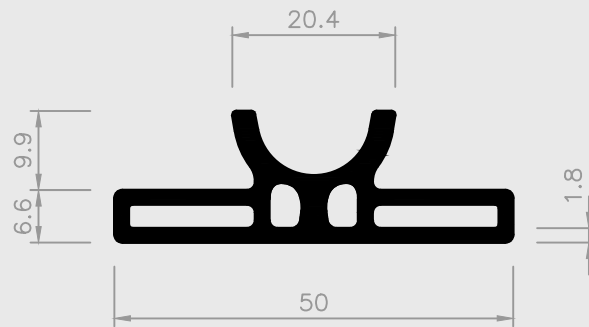

Nr. 38/02 H

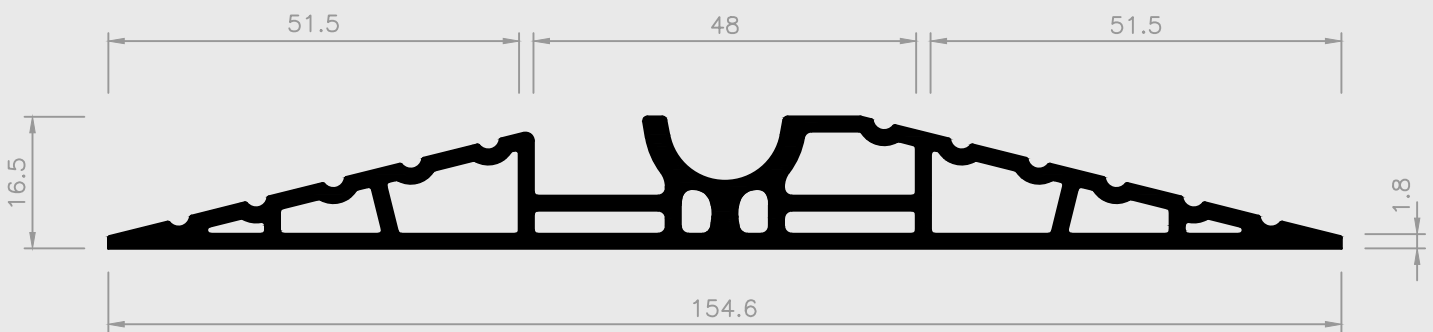

Nr. 38/03 H

= Hart PVC
 = Weich PVC | HH = Halbhart PVC
 = Andere Kunststoffe

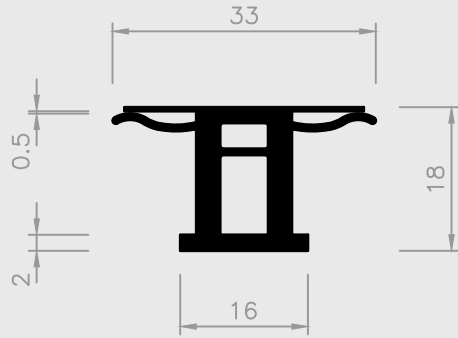

Nr. 42/07A H

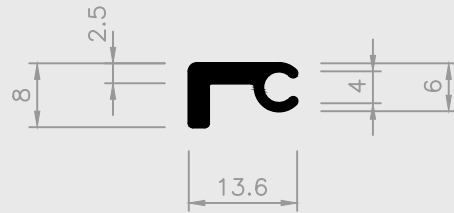

Nr. 42/14 H

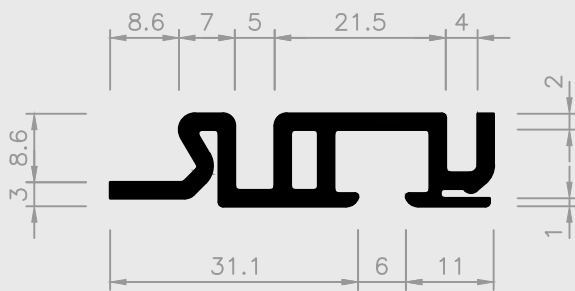

Nr. 42/22 H

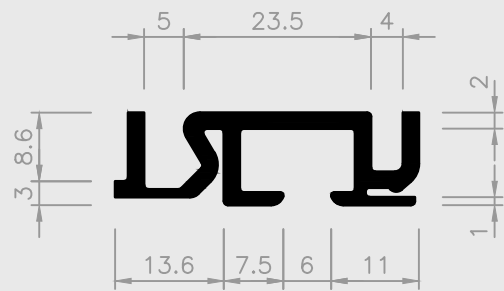

Nr. 42/23 H

= Hart PVC
 = Weich PVC | HH = Halbhart PVC
 = Andere Kunststoffe

20 | SONDERPROFILE

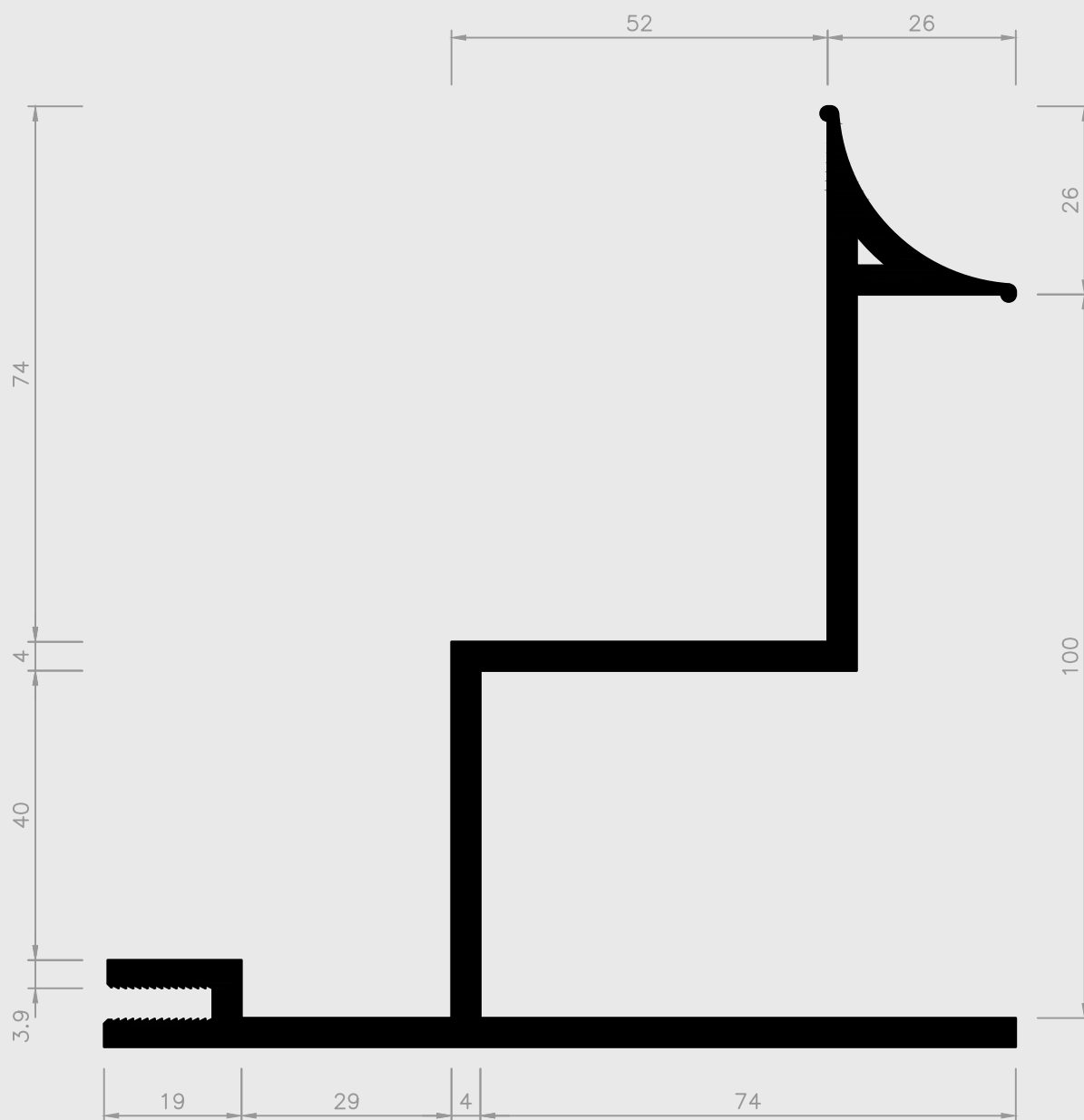

Nr. 42/15 H

■ = Hart PVC ■ = Weich PVC | HH = Halbhart PVC □ = Andere Kunststoffe

20 | SONDERPROFILE

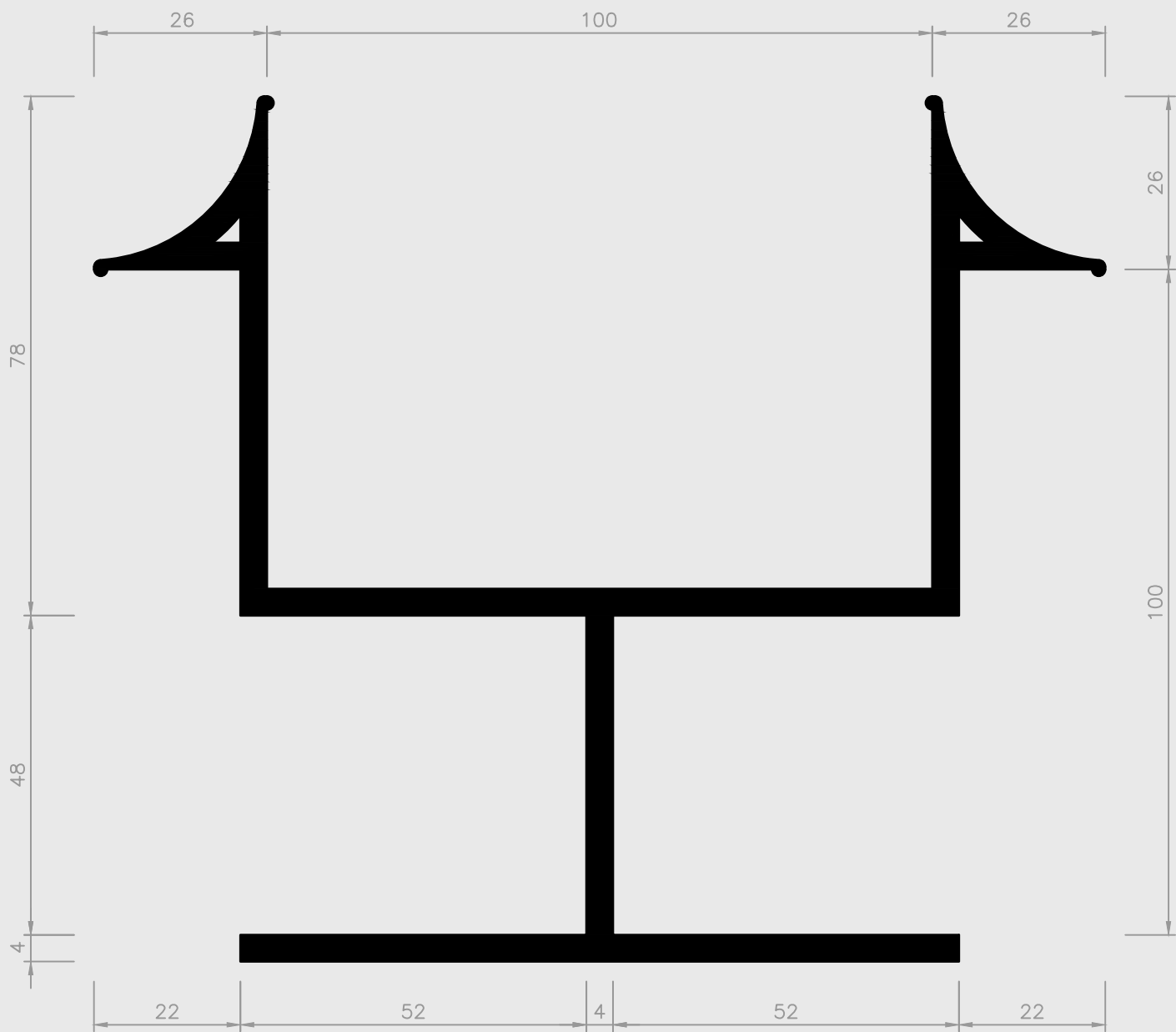

Nr. 42/20 H

■ = Hart PVC ■ = Weich PVC | HH = Halbhart PVC □ = Andere Kunststoffe

20 | SONDERPROFILE



Nr. 42/16 H

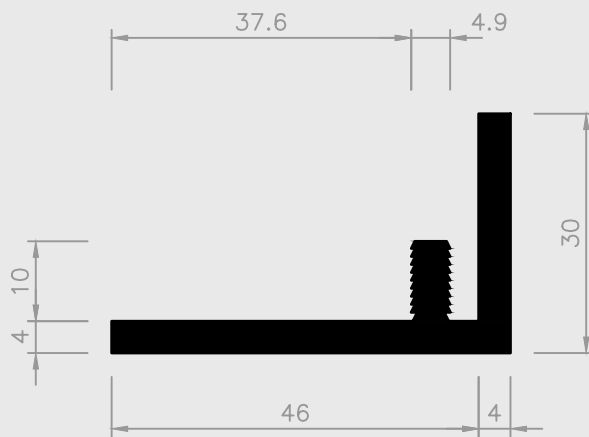

Nr. 42/17 H

■ = Hart PVC ■ = Weich PVC | HH = Halbhart PVC □ = Andere Kunststoffe



Nr. 42/18 H



Nr. 42/19 H

■ = Hart PVC ■ = Weich PVC | HH = Halhart PVC □ = Andere Kunststoffe

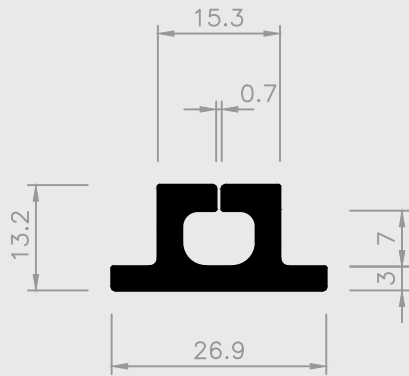

Nr. 9/57A H

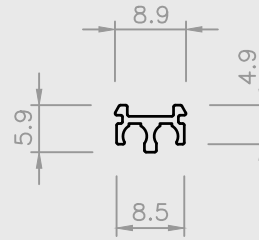

Nr. 23/06 PC

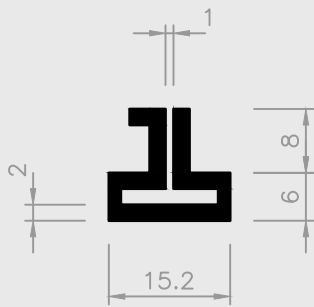

Nr. 30/37 H

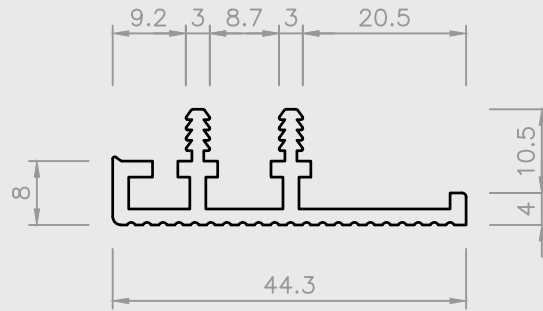

Nr. 35/42 PC-ABS

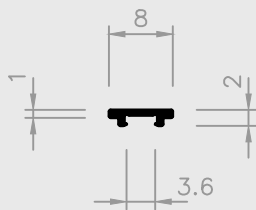

Nr. 40/46 H

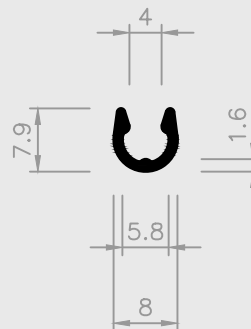

Nr. 50/41 H

= Hart PVC
 = Weich PVC | HH = Halbhart PVC
 = Andere Kunststoffe

20 | SONDERPROFILE

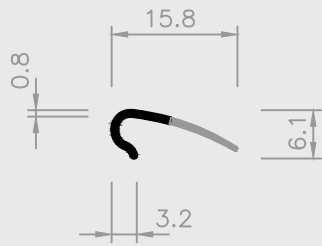

Nr. 4/34 H+W

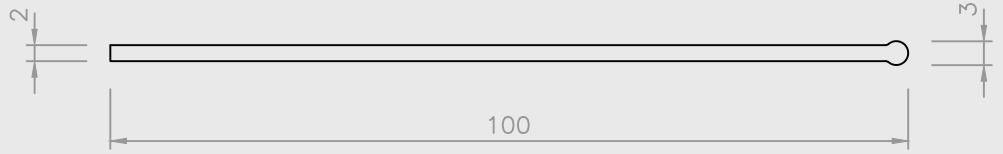

Nr. 7/52 PE

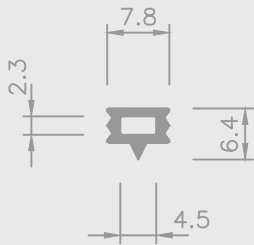

Nr. 8/54 W

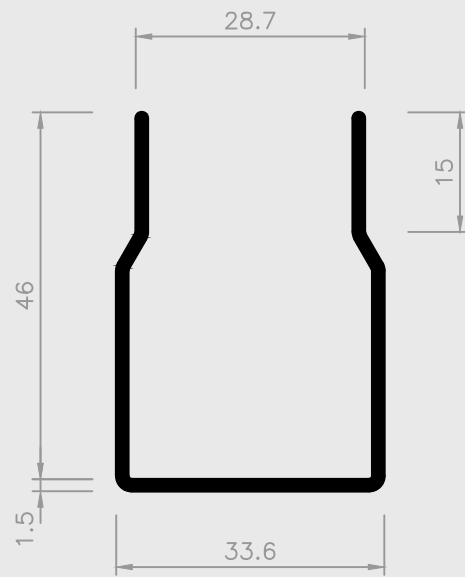

Nr. 20/47 H

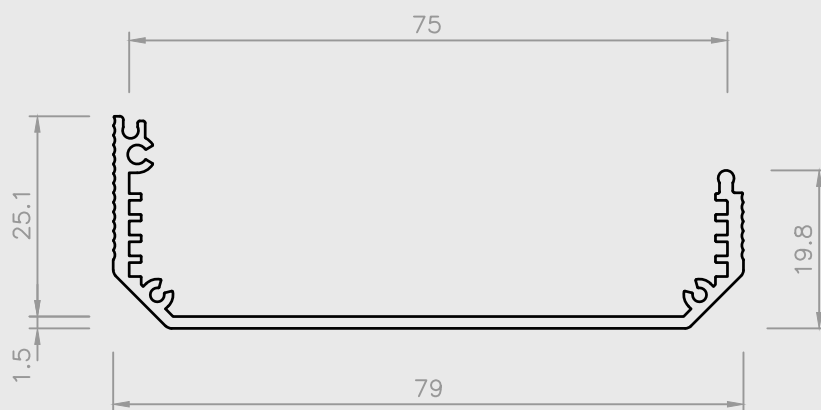

Nr. 21/05 ABS

= Hart PVC
 = Weich PVC | HH = Halbhart PVC
 = Andere Kunststoffe

20 | SONDERPROFILE

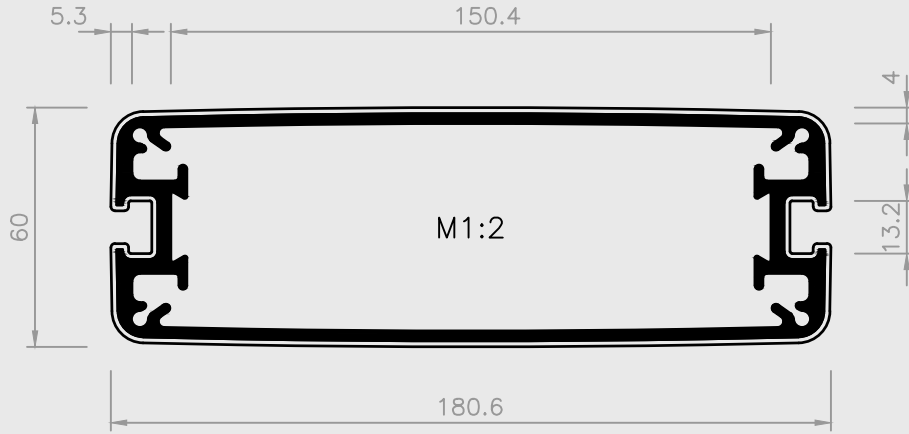

Nr. 44/01 H+PMMA

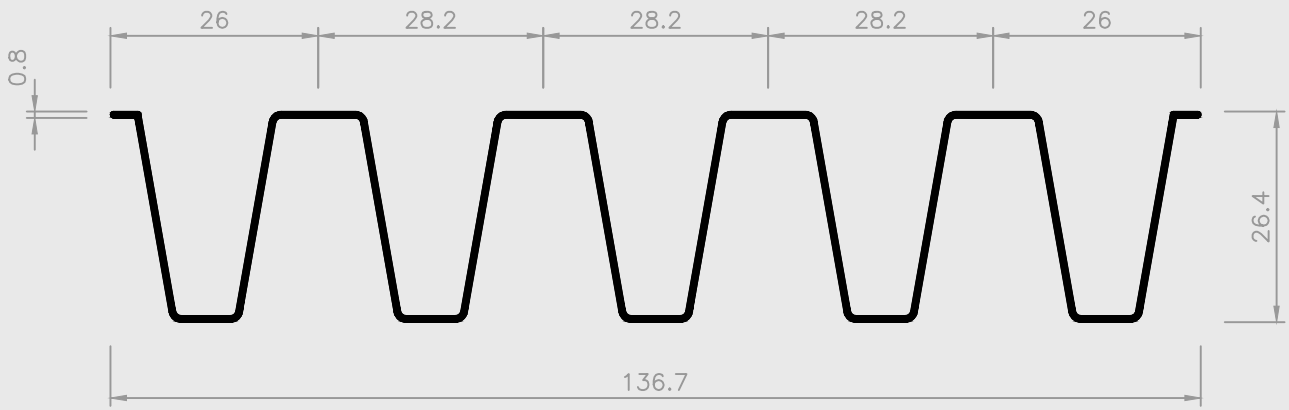

Nr. 51/40 H

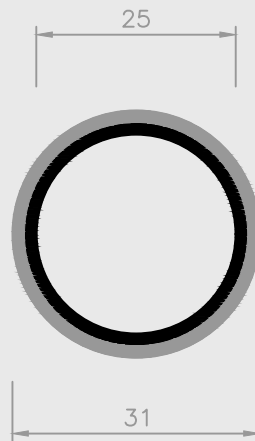

Nr. 54/71 H+W

= Hart PVC
 = Weich PVC | HH = Halbhart PVC
 = Andere Kunststoffe